

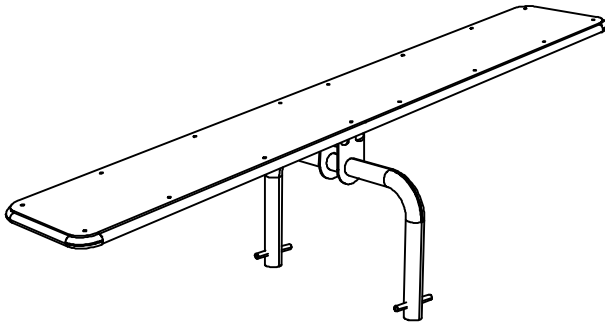

BARKS & REC
 315 MAIN ST
 ECLECTIC, AL 36024
 TOLL FREE: 1-866-398-3992
 www.barksandrec.com

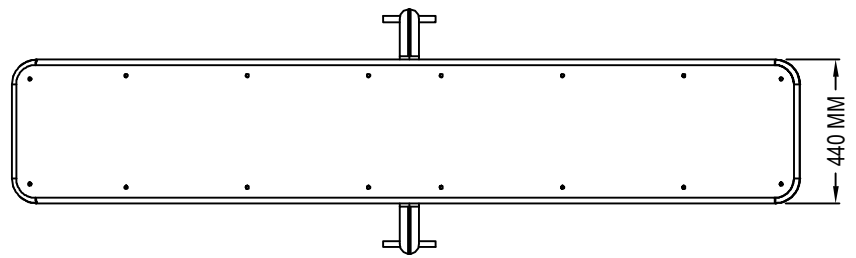

PERSPECTIVE



TOP VIEW

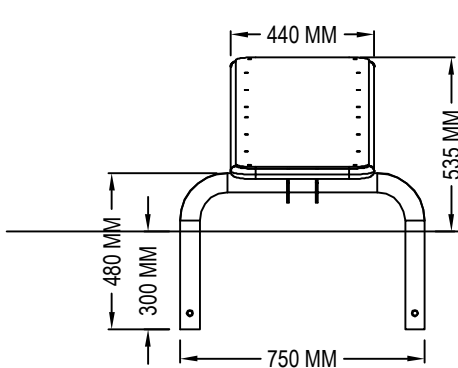

SIDE VIEW

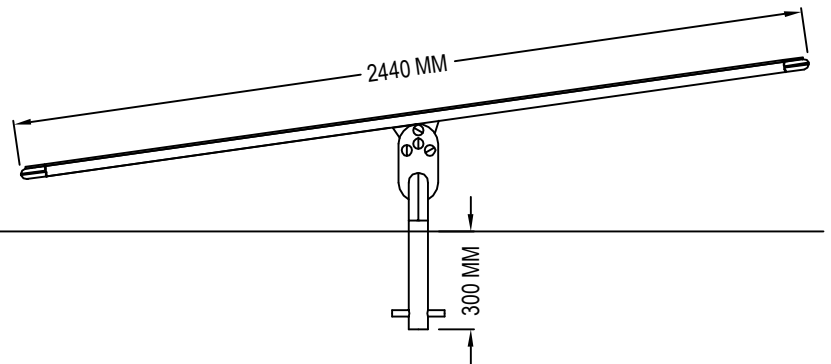

FRONT VIEW

NOTES:

1. INSTALLATION TO BE COMPLETED IN ACCORDANCE WITH MANUFACTURER'S SPECIFICATIONS.
2. DO NOT SCALE DRAWING.
3. THIS DRAWING IS INTENDED FOR USE BY ARCHITECTS, ENGINEERS, CONTRACTORS, CONSULTANTS AND DESIGN PROFESSIONALS FOR PLANNING PURPOSES ONLY. THIS DRAWING MAY NOT BE USED FOR CONSTRUCTION.
4. ALL INFORMATION CONTAINED HEREIN WAS CURRENT AT THE TIME OF DEVELOPMENT BUT MUST BE REVIEWED AND APPROVED BY THE PRODUCT MANUFACTURER TO BE CONSIDERED ACCURATE.
5. ADDITIONAL INFORMATION (MAY NOT BE VISIBLE) AVAILABLE IN MODEL SPACE.
6. CONTRACTOR'S NOTE: FOR PRODUCT AND COMPANY INFORMATION VISIT www.CADdetails.com/info AND ENTER REFERENCE NUMBER 5206-012

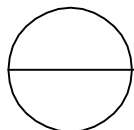

BARKS & REC PRODUCTS

TEETER TOTTER