

CF-043-8DWYW

8' PERFORATED BENCH PORTABLE DESIGN



Please take the time to locate and identify each part. Assemble the units on a smooth flat surface. It is also helpful to lay the tops and seats on cardboard or a drop cloth to prevent scratching of the surface during assembly. All parts have been pre-cut and pre-drilled for ease of assembly. All holes are slotted to allow for easy assembly and for final levelling of tops and seats to frames. Fully assemble all parts without totally tightening nuts and bolts. After all assembled go back and retighten nuts to bolts. **DO NOT OVER TIGHTEN NUTS TO BOLTS.** Over tightened nuts can crack the plastisol coating. All the necessary quantities of parts required are listed in this assembly instruction.

DO NOT BEGIN ASSEMBLY UNTIL YOU HAVE READ THESE INSTRUCTIONS AND ARE FAMILIAR WITH THE PARTS.

PARTS IDENTIFICATION



(A) 8' PERF SEAT



(B) BENCH FRAME



(B) BENCH FRAME

PARTS LIST

ITEM	PART#	DESCRIPTION	QTY.
A	8SPERF	8' PERF SEAT	1
B	FBP	BENCH FRAME	2
C	DB	DIAGONAL	2

ITEM	HARDWARE DESCRIPTION	QTY.
HW1	5/16" X 18 NYL LOCKNUTS	7
HW2	5/16" X 18GA CAP BOLTS	7
HW3	5/16" FLAT WASHERS	14
HW4	BOLT GUARDS	7

ASSEMBLY TOOLS REQUIRED
2- 1/2" WRENCHES

HARDWARE IDENTIFICATION



(HW1) 5/16" X 18
NYL LOCKNUTS



(HW2) 5/16" X 18
GAUGE CAP BOLTS



(HW3) 5/16"
FLAT WASHERS



(HW4) BOLT
GUARDS

ASSEMBLY PROCEDURES

STEP 1

MOUNT THE FRAMES TO THE SEATS, THE ANGLE IRONS ON THE FRAMES MUST BE BOLTED TO THE OUTSIDE OF THE BRACES ON THE SEAT. FASTEN BY MEANS OF FOUR 5/16" X 1 1/2" HEXBOLT, EIGHT 5/16" FLAT WASHERS, AND FOUR 5/16" NYLOCK NUTS. Hand tighten only at this time.

STEP 2

MOUNT THE SET OF DIAGONALS TO THE HOLE ON THE CENTER BRACE OF THE SEAT. MOUNT THE OTHER END OF THE DIAGONALS TO THE TAB ON EACH END OF THE FRAMES. THE DIAGONALS ARE FASTENED TOGETHER BY MEANS OF THREE 5/16" X 1 1/2" HEXBOLTS, SIX 5/16" FLAT WASHERS, AND THREE 5/16" NYLOCK NUTS.

STEP 3

TIGHTEN ALL NUTS ON ALL BOLTS AND PLACE THE BOLT GUARDS ON ALL NUTS. **DO NOT OVER TIGHTEN THE NUTS AS THIS COULD CAUSE THE PLASTISOL COATING TO CRACK.**



ANGLE BOLTS TO INSIDE OF BRACE, FACING EACH OTHER.

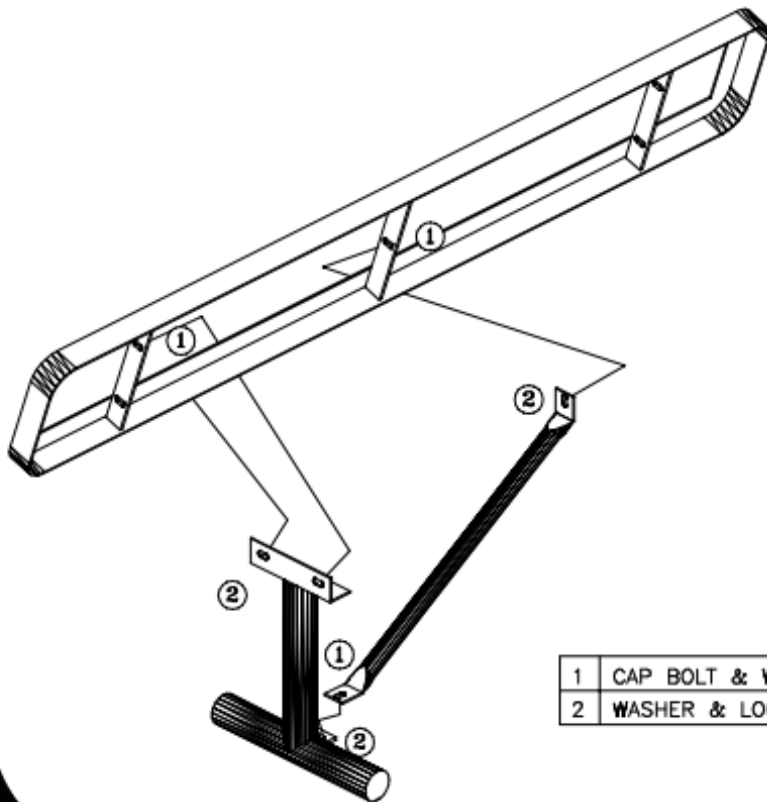

1	CAP BOLT & WASHER
2	WASHER & LOCKNUT

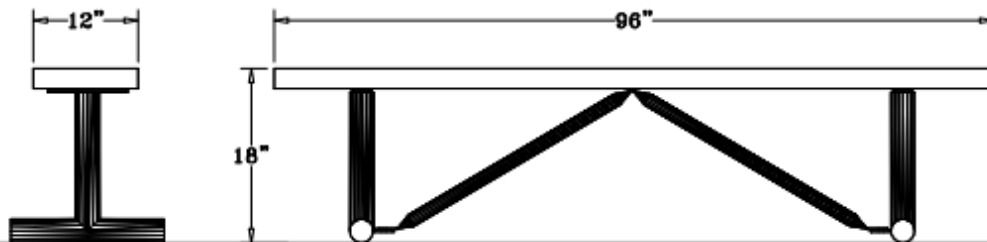

SPECIFICATIONS

8' POLY VINYL COATED 11GA. PUNCHED STEEL BENCH.
ALL EDGES AND CORNERS ARE ROLLED. FRAME IS PORTABLE DESIGN.
COATED WITH A 1/8" TO 1/4" THICK PLASTISOL ULTRAVIOLET STABILIZED VINYL COATING FUSED
AND BAKED TO A 90% GLOSS.
SEAT HEIGHT IS 18" APPROXIMATELY. TOTAL OVERALL DIMENSIONS ARE 96" X 12".
SEAT IS MADE FROM 11GA. 3/4" HOLE PRECISION PUNCHED STEEL.
ALL EDGED ARE ROLLED TO A 2" DIA. TO FORM A ROUNDED EDGE FOR SMOOTHNESS AND SAFETY.
A 1/4" X 1 1/2" STEEL BRACING IS WELDED TO THE UNDERSIDE FOR ADDED SUPPORT.
FRAMES ARE MADE OF 2 3/8" HEAVY STEEL TUBING THAT IS GALVANIZED INSIDE AND OUT AND
MEETS OR EXCEEDS THE YIELD AND TENSILE OF SCH 40 PIPE. CONSTRUCTED SO AS TO PROHIBIT
RAIN WATER FROM COLLECTING AT GROUND LEVEL.
COATED WITH A BAKED ON POLYESTER POWDER COAT FINISH.
DIAGONAL IS MADE OF 1" GALVANIZED TUBING.
ALL HARDWARE IS NON-CORROSIVE.
WEIGHT FOR THE B8PERFP IS 108 LBS.

MAINTENANCE

To maintain luster it is recommended to wash, rinse, and dry the units after prolonged use.
Check for loose bolts and nuts and tighten as needed. Contact the factory for genuine
Webcoat part replacements if needed.