

CF-043-ZLYSZ

4' CLASSIC STYLE BENCH WITH BACK ADD ON PORTABLE DESIGN



Please take the time to locate and identify each part. Assemble the units on a smooth flat surface. It is also helpful to lay the tops and seats on cardboard or a drop cloth to prevent scratching of the surface during assembly. All parts have been pre-cut and pre-drilled for ease of assembly. All holes are slotted to allow for easy assembly and for final levelling of tops and seats to frames. Fully assembly all parts without totally tightening nuts and bolts. After all assembled go back and retighten nuts to bolts. **DO NOT OVER TIGHTEN NUTS TO BOLTS.** Over tightened nuts can crack the plastisol coating. All the necessary quantities of parts required are listed in this assembly instruction.

DO NOT BEGIN ASSEMBLY UNTIL YOU HAVE READ THESE INSTRUCTIONS AND ARE FAMILIAR WITH THE PARTS.

PARTS IDENTIFICATION

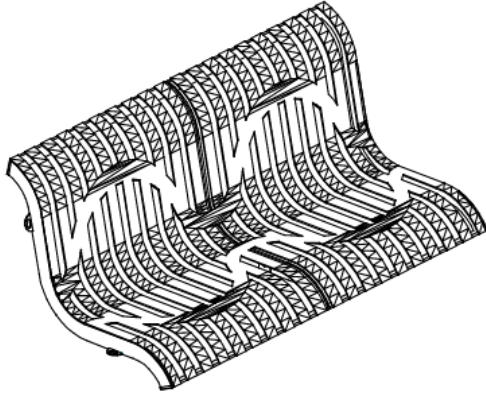

(A) 4' CLASSIC BENCH

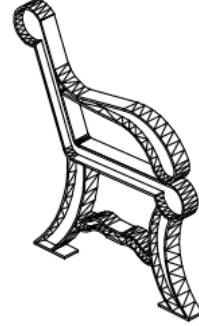

(B) BENCH FRAME

PARTS LIST

| ITEM | PART# | DESCRIPTION | QTY. |
|------|-----------|-----------------|------|
| A | S4WBCLASS | 4' CLASSIC SEAT | 1 |
| B | FBWBVILLA | VILLA FRAME | 1 |

| ITEM | HARDWARE DESCRIPTION | QTY. |
|------|----------------------|------|
| HW1 | 1/2" NUTS | 4 |
| HW2 | 1/2" WASHERS | 4 |

ASSEMBLY TOOLS REQUIRED
2- 3/4" WRENCHES

HARDWARE IDENTIFICATION



(HW5) 1/2" NUTS



(HW6) 1/2" WASHERS

ASSEMBLY PROCEDURES

STEP 1

SET FRAME ON LEVEL SURFACE.

STEP 2

MOUNT BENCH SEAT TO FRAME BY LINING UP THE TWO BOLTS WELDED ON THE FRAME TO THE TWO HOLES ON THE SEAT. **HAND TIGHTEN AT THIS TIME ONLY.**

STEP 3

NOW THAT ALL PARTS ARE ASSEMBLED, SQUARE AND ALIGN ALL PARTS OF THE UNIT THEN TIGHTEN ALL NUTS AND BOLTS SECURELY. **DO NOT OVER TIGHTEN THE NUTS AS THIS COULD CAUSE THE PLASTISOL COATING TO CRACK.**

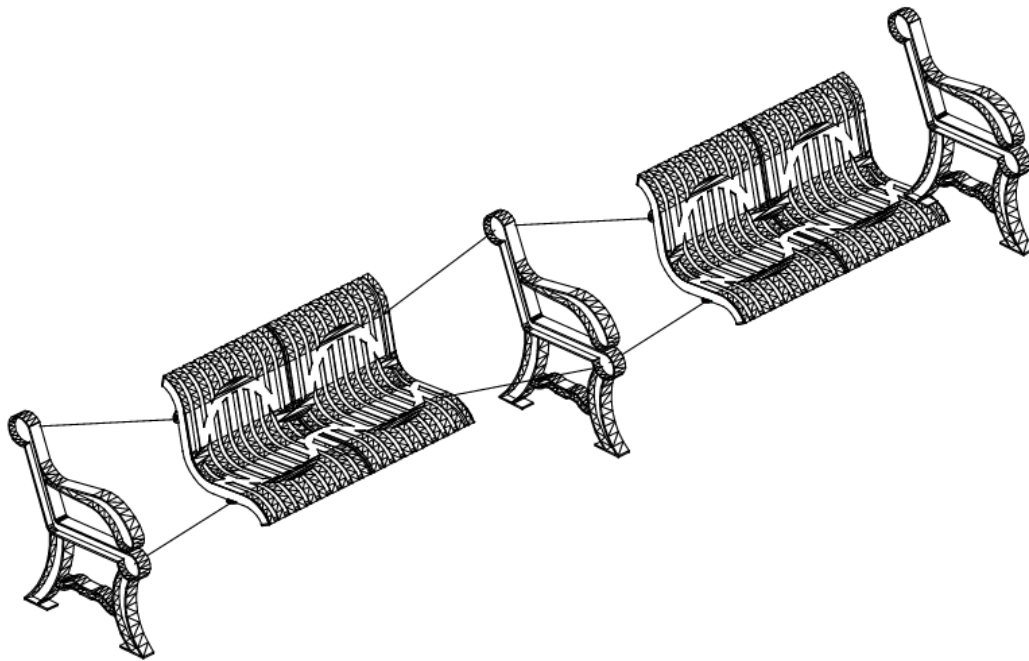

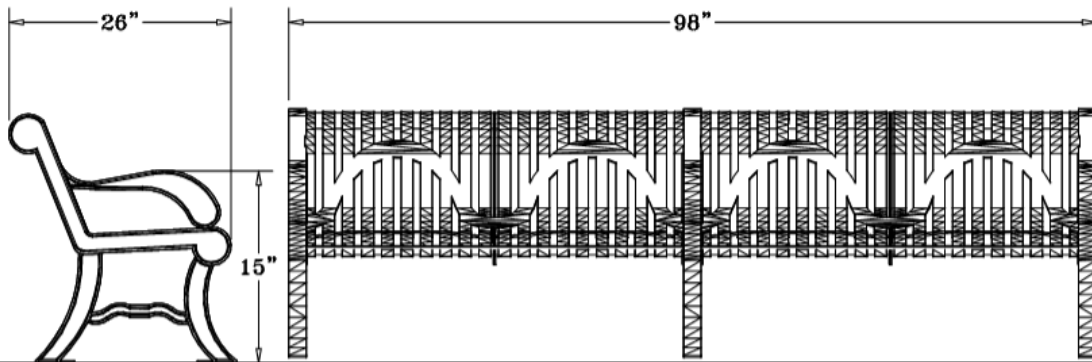

SPECIFICATIONS

4' POLY VINYL COATED CLASSIC STYLE ADD ON BENCH WITH BACK.
FRAME IS PORTABLE DESIGN.

COATED WITH A 1/8" TO 1/4" THICK PLASTISOL ULTRAVIOLET STABILIZED VINYL COATING
FUSED AND BAKED TO A 90% GLOSS.

SEAT HEIGHT IS 15" APPROXIMATELY.
TOTAL OVERALL DIMENSIONS ARE 48" X 98" APPROXIMATELY.

SEAT IS MADE FROM 11 GA. STEEL.

FRAME IS ONE PIECE CAST ALUMINUM DESIGN, FINISHED WITH A BAKED ON POLYESTER
POWDER COAT FINISH.

ALL HARDWARE IS NON-CORROSIVE.
WEIGHT FOR THE B4WBCLASSIC-ADDON IS 86 LBS.

MAINTENANCE

To maintain luster it is recommended to wash, rinse, and dry the units after prolonged use.
Check for loose bolts and nuts and tighten as needed. Contact the factory for genuine
Webcoat part replacements if needed.