

CF-043-71QSC

CROWN STYLE ASHURN



Please take the time to locate and identify each part. Assemble the units on a smooth flat surface. It is also helpful to lay the tops and seats on cardboard or a drop cloth to prevent scratching of the surface during assembly. All parts have been pre-cut and pre-drilled for ease of assembly. All holes are slotted to allow for easy assembly and for final levelling of tops and seats to frames. Fully assemble all parts without totally tightening nuts and bolts. After all assembled go back and retighten nuts to bolts. **DO NOT OVER TIGHTEN NUTS TO BOLTS.** Over tightening nuts can crack the Plastisol coating. All the necessary quantities of parts required are listed in these assembly instructions.

DO NOT BEGIN ASSEMBLY UNTIL YOU HAVE READ THESE INSTRUCTIONS AND ARE FAMILIAR WITH THE PARTS.

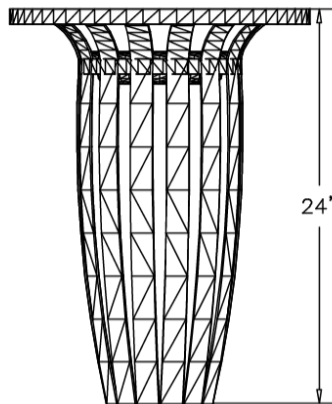
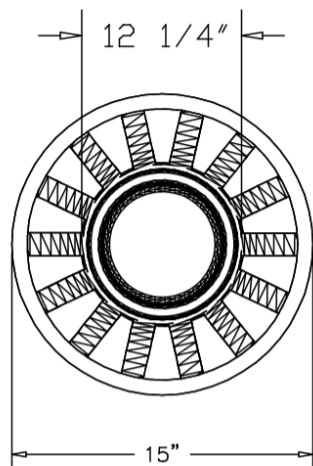

STEEL LINER

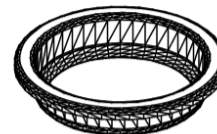

FOR A SURFACE MOUNT, INSERT
2 5/16" X 4" LAG BOLTS
INTO THE CONCRETE

SPECIFICATIONS

24" X 15" POLY VINYL RIBBED METAL ASHURN WITH A CHROME PLATED STEEL PAN.

COATED WITH A 1/8" TO 1/4" THICK PLASTISOL ULTRAVIOLET STABILIZED VINYL COATING FUSED AND BAKED TO A 90% GLOSS.

TOTAL OVERALL DIMENSIONS ARE 24" X 15".

ASHURN IS MADE OF ROLLED 11GA. STEEL WITH 1/4" FLAT STEEL FOR THE TOP AND BOTTOM.

ON TOP IS A CHROME PLATED STEEL PAN SECURED WITH A CHAIN FOR EASE OF EMPTYING.

ALL HARDWARE IS NON-CORROSIVE.
WEIGHT FOR THE ASHURN CROWN IS 28 LBS.

MAINTENANCE

To maintain luster it is recommended to wash, rinse, and dry the units after prolonged use. Check for loose bolts and nuts and tighten as needed. Contact the factory for genuine Webcoat part replacements if needed.