

## SPECS AND INSTALL INSTRUCTIONS

### Standard Plastic-Coated Wave Style Bike Rack

SKU:

8' CF-ZMPNW

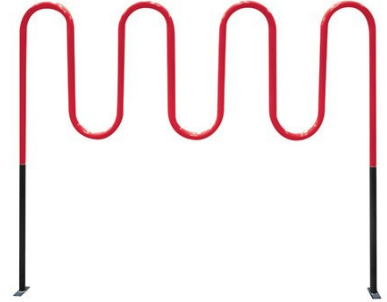

#### Product maintenance

Inspect all hardware and fasteners, regularly check that all nuts and bolts are secure. Periodically examine for any signs of vandalism on any of your products thermoplastic surfaces. If any thermoplastic surface is vandalized by spray paint, simply take a rag and an aerosol can of WD40® and wipe the spray paint off. If the thermoplastic surface has any cuts simply take an industrial heat gun to the affected area. For regular cleaning use soap and water.

#### Thermoplastic Coating

Our is covered in a copolymer-based thermoplastic powder coating. Thermoplastic is environmentally safe, the coating will never fade, crack, peel, warp, or discolor for the life of the product. Thermoplastic has the best adhesion rate of any other process. This keeps the metal base free of any corrosion possibilities. Thermoplastic is applied at a thickness of 25-30 mils. This allows maximum protection with the best possible surface. Thermoplastic can be easily repaired. Cuts are repaired by heating the affected area with an industrial heat gun. The thermoplastic will rebound itself. The properties of thermoplastic also make spray painting difficult for vandals. Simply wash product with a standard industrial cleaner.

#### Specifications

##### General

All wave racks are 2 3/8" O.D. galvanized steel pipe available in two styles; in-ground post mount and plate surface mount. In-ground post mount styles ship in three pieces for assembly. Plate surface mount style is ready to install. In-ground post mount style is available with optional cover caps. Both styles are also available with thermoplastic coating.

Check for any damaged or missing parts of if you have problems assembling your furniture / equipment please call our Customer Service Representatives.

# Wave Rack Specs [same for In-Ground and Surface Mount]

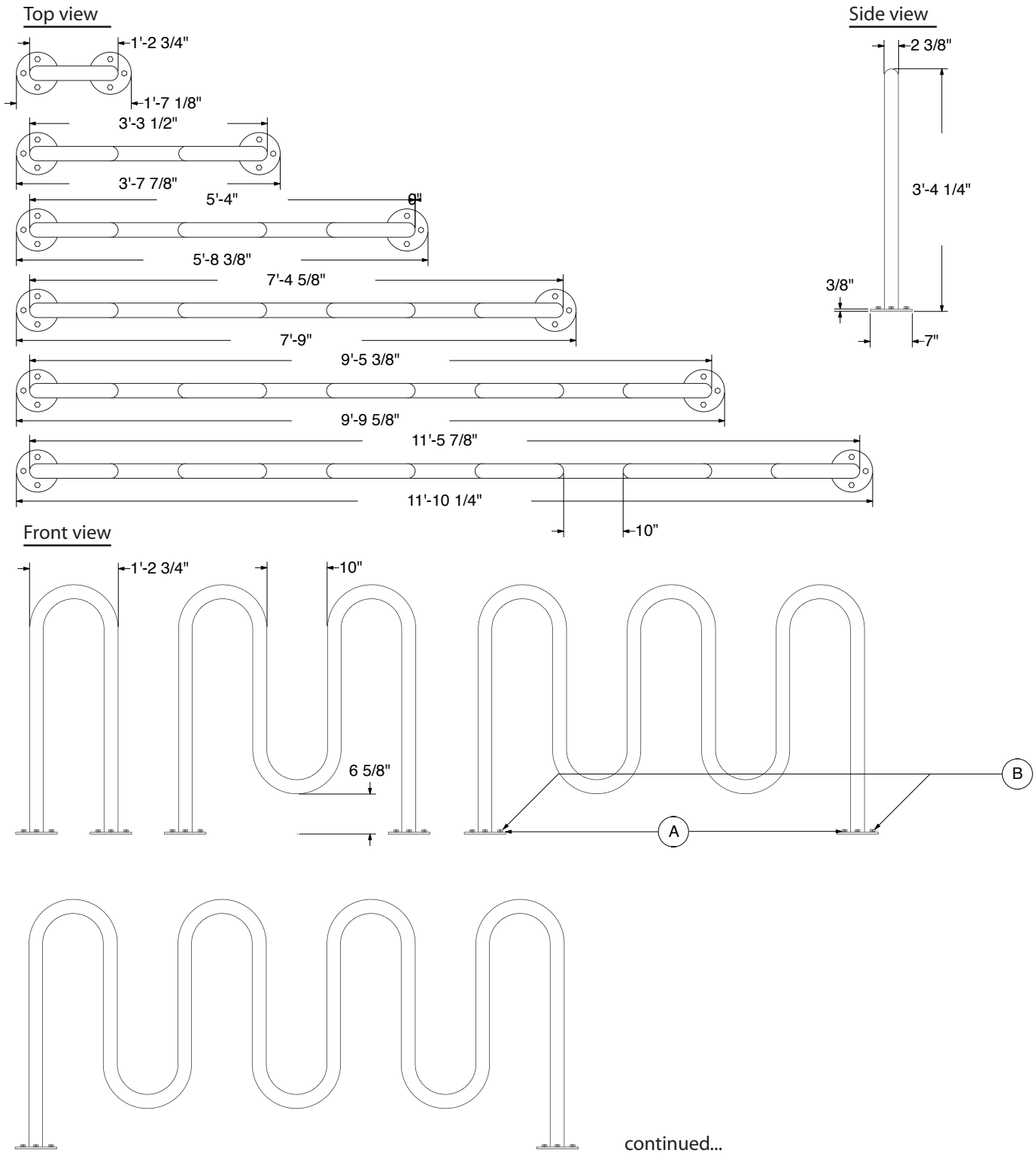

## Quantities (per rack)

- A - 1/2" Washer - qty 8
- B - 1/2" Hex Nut - qty 8
  
- A - 1/2" Washer - qty 12
- B - 1/2" Hex Nut - qty 12

## Hardware (inc. w/

models only)

(A) 1/2" Washer



(B) 1/2" Hex Nut



scale 1/2" = 1'



Wave Rack Specs [same for In-Ground and Surface Mount]

scale 1/2" = 1'

Front view

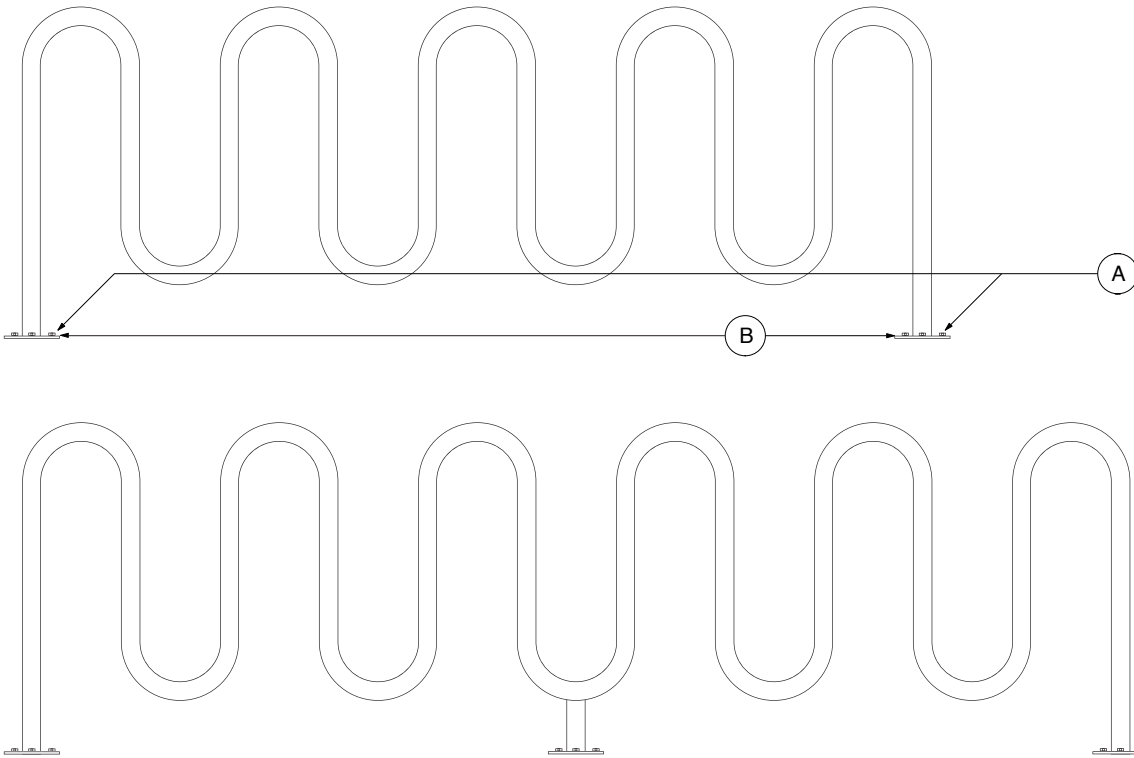
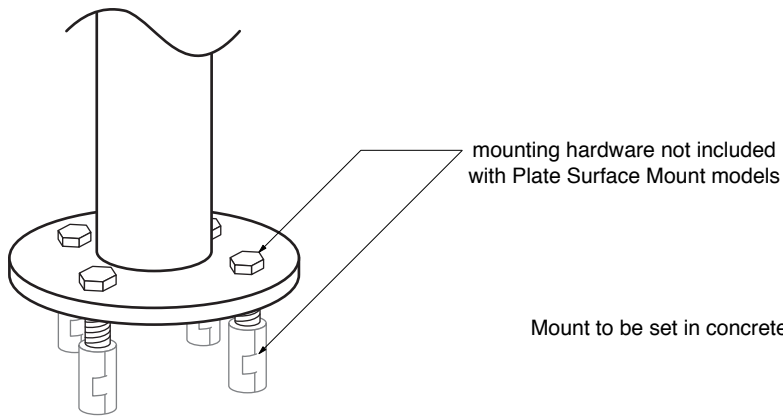
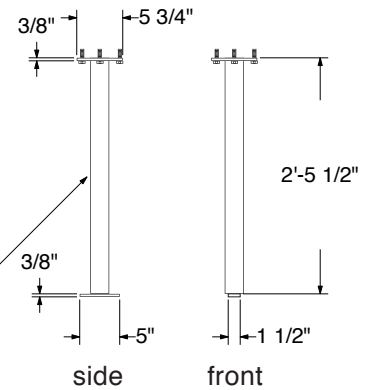

Plate Surface Mount Detail



In-Ground Post Mount Detail



scale 1/2" = 1'



Quantities (per rack)

- A - 1/2" Washer - qty 8
- B - 1/2" Hex Nut - qty 8
  
- A - 1/2" Washer - qty 12
- B - 1/2" Hex Nut - qty 12

Hardware (inc. w/ models only)

- Ⓐ 1/2" Washer 
- Ⓑ 1/2" Hex Nut 

scale 1/2" = 1'



# In-Ground Post Mount

scale 1/2" = 1'

Front view

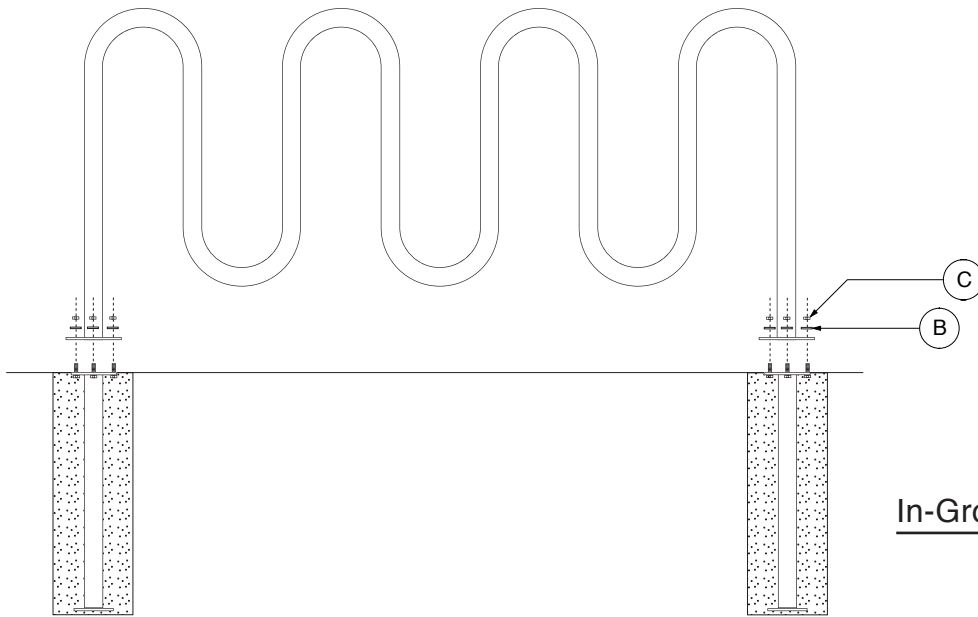

## In-Ground Installation with Cover Caps

scale 1" = 1'

mount plate of rack is threaded onto 4 bolts and tightened with nuts

optional 2-pc. cover caps are placed over the plate of the mounted wave rack and screwed on

embedded in-ground mount has 4 bolts sticking upward

in-ground mount embedded in concrete poured into post-hole, 30" deep

5" x 1.5" x .375" flatbar welded to in-ground mount at bottom

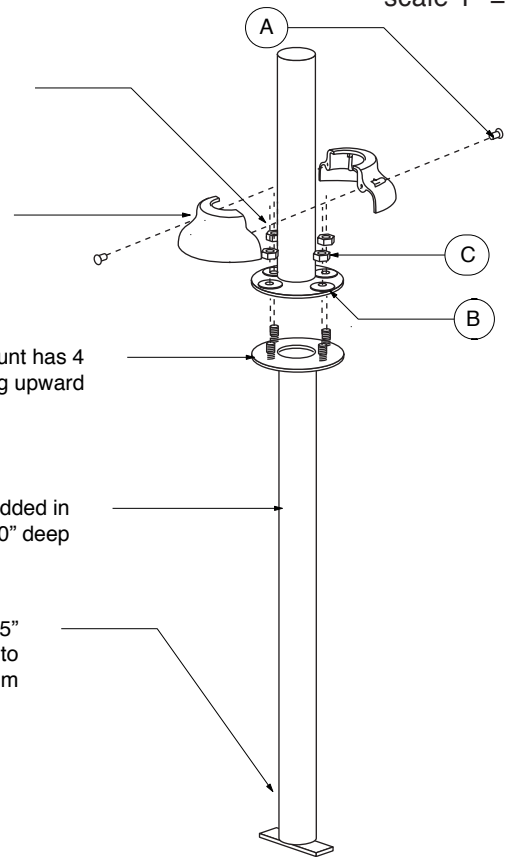

## In-Ground Cover Caps [optional]

scale 2" = 1'

Top view

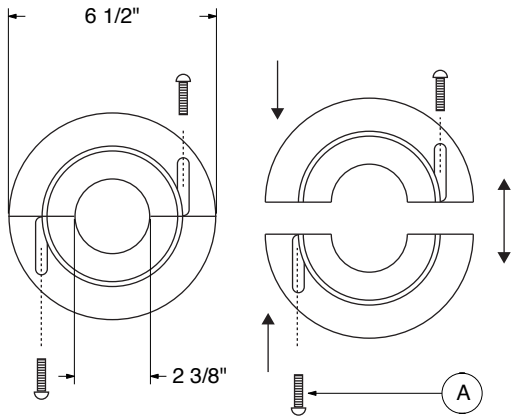

Side view

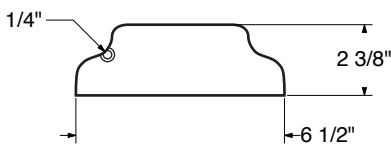



Iso view



### Quantities (per rack)

A	- 3/16" Machine head	- qty 4 (inc. w/optional cover caps only)
B	- 1/2" Washer	- qty 8
C	- 1/2" Hex Nut	- qty 8
A	- 3/16" Machine head	- qty 6 (inc. w/optional cover caps only)
B	- 1/2" Washer	- qty 12
C	- 1/2" Hex Nut	- qty 12

### Hardware (inc. w/ models only)

Ⓐ	3/16" Machine head	
Ⓑ	1/2" Washer	
Ⓒ	1/2" Hex Nut	



# Assembly Instructions

---

## In-Ground Post Mount Wave Bike Racks

## Plate Surface Mount Wave Bike Racks

---

### In-Ground Step 1:

Begin by placing the in-ground mounts bolt first through the bottom of the mount plates of your wave rack. Then place the included 1 3/8" washers over the tops of the protruding bolts. The complete the assembly tightening the included 1/2" hex nuts on all of the bolts. [see fig. 1] Then use the assembled rack to measure the distance of your mounting holes.

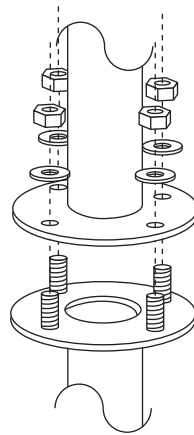

fig. 1

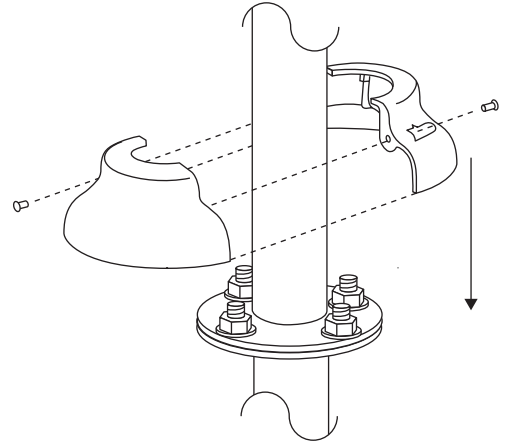

fig. 2

---

### In-Ground Step 2:

Using the measure of distance between the in-ground mounts, dig two holes 30" deep with a post-hole digger or auger of at least 8" in diameter. Prepare your concrete. Then set the assembled wave rack into the holes with the mounts in the holes. Pour the prepared concrete into each hole [three in the case of the BKP/G13] and securely prop up the rack to make sure the concrete cures with the rack properly perpendicular and true.

---

### In-Ground Optional Cover Caps Step 3:

After the concrete cures and your wave rack is secure, the optional cover caps can be added to the rack to cover the mounting hardware. Each cap half comes with a 3/16" regular screw to tighten the cap halves together. Using a medium blade regular screwdriver, loosely tighten the two screws included with the cover cap and push the cap down until it sits on the surface of the ground where the rack is mounted. Once the cap is sitting on the ground, finish tightening the screws completely.

---

### Surface Mount Step 1:

Begin by placing the wave rack where you want it to be installed. Mark the concrete at each hole in the surface mount plates. Mounting hardware is not included with the rack. We recommend metal hit anchors that can be driven in with a hammer.

---

### Surface Mount Step 2:

Drill hole in concrete equal to diameter of anchor being used. Hole depth should be at least 1/4" deeper than the anchor embedment. Then clean out hole of all dust and shavings. Insert metal hit anchor, slit end first through the mounting plate and into hole. The bottom of the head must be sitting flush with the fixture plate. Hammer nail flush into head of anchor body. The metal hit anchor is now set. Repeat for each hole drilled and wave rack is now secured.

