

## SPECS AND INSTALL INSTRUCTIONS

### Perforated Metal Backless Park Bench

SKU:

---

4' CF-D6EUS      6' CF-2LWRS  
8' CF-IKPVC      10' CF-LHS7Z  
15' CF-KWWQD



### Product maintenance

Inspect all hardware and fasteners, regularly check that all nuts and bolts are secure. Periodically examine for any signs of vandalism on any of your products thermoplastic surfaces. If any thermoplastic surface is vandalized by spray paint, simple take a rag and a aerosol can of WD40 ® and wipe the spray paint off. If the thermoplastic surface has any cuts simple take an industrial heat gun to the affected area. For regular cleaning use soap and water.

### Thermoplastic Coating

Our outdoor furniture is covered in a copolymer-based thermoplastic powder coating. Thermoplastic is environmentally safe, the coating will never fade, crack, peel, warp, or discolor for the life of the product. Thermoplastic has the best adhesion rate of any other process. This keeps the metal base free of any corrosion possibilities. Thermoplastic is applied at a thickness of 25-30 mils. This allows maximum protection with the best possible surface. Thermoplastic can be easily repaired. Cuts are repaired by heating the affected area with an industrial heat gun. The thermoplastic will rebound itself. The properties of thermoplastic also make spray painting difficult for vandals. Simply wash product with a standard industrial cleaner.

### Specifications

#### General

All seats and backs of the listed products above are protected with Thermoplastic coating. Black powder coated galvanized steel legs and support structure. Available in expanded metal and perforated metals seats and backs. Personalization is also available.

Check for any damaged or missing parts of if you have problems assembling your furniture / equipment please call our Customer Service Representatives.

# Standard Metal Bench with Back

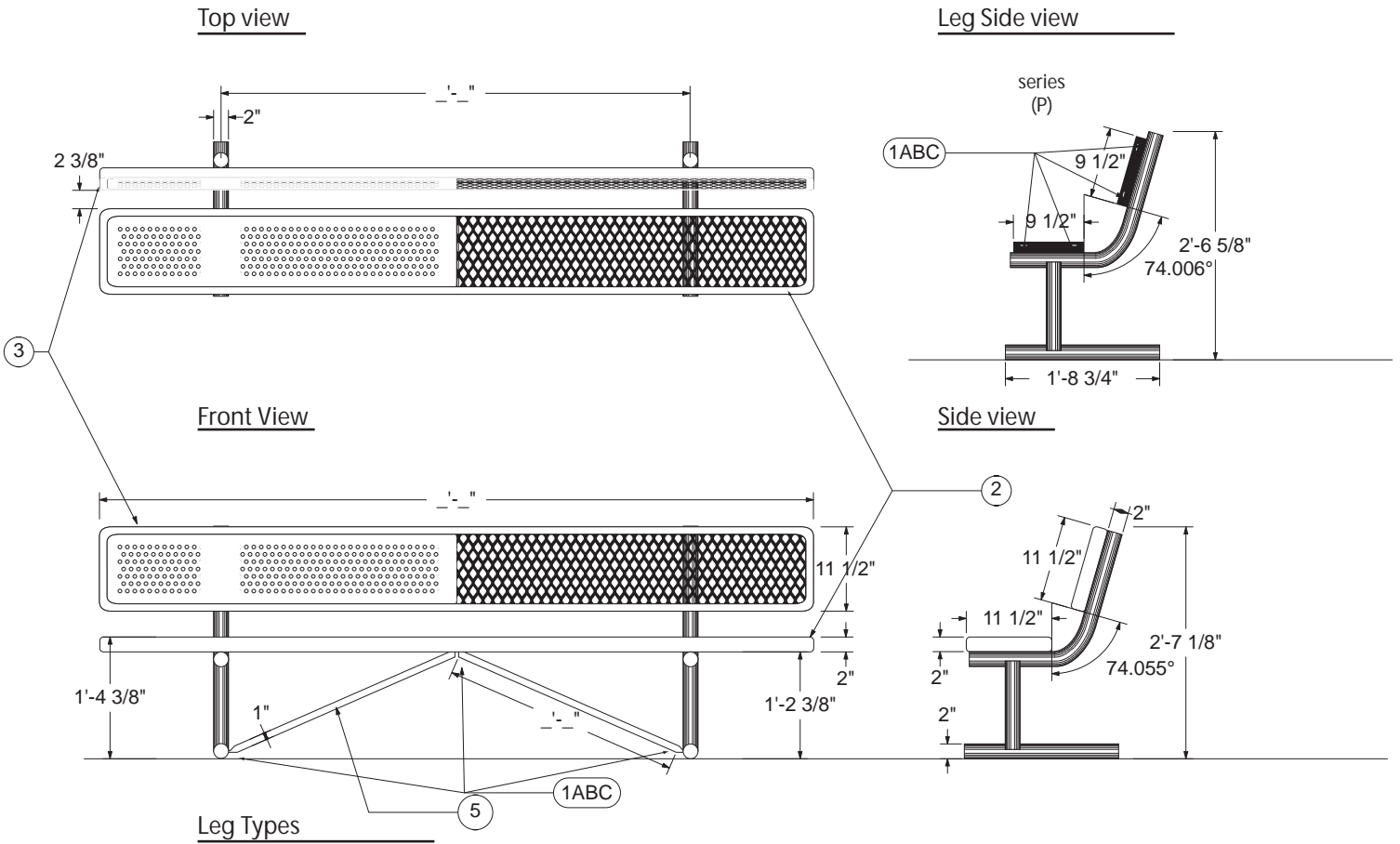

Front View

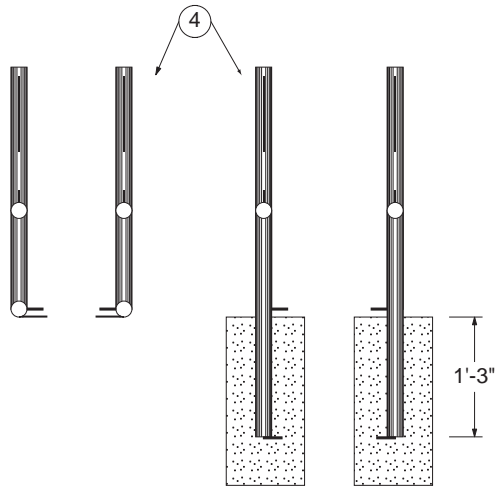

Top view

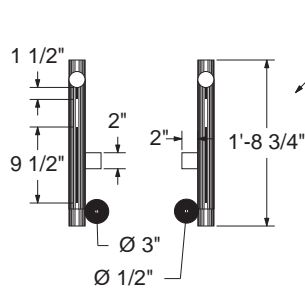

Side view

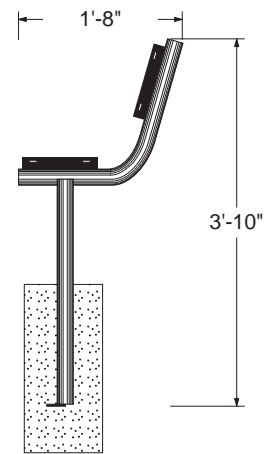

Available Styles



Expanded Metal

Perforated Metal

Quantities (per bench)

1A - 5/16" Hex head bolts	- qty 11
1B - 5/16" Washer	- qty 22
1C - 5/16" Nut	- qty 11
2 - Bench seat	- qty 1
3 - Bench back	- qty 1
4 - Leg Types (per bench)	- qty 2
5 - Cross braces	- qty 2

Hardware

Ⓐ 5/16" Hex head bolt	
Ⓑ 5/16" Washer	
Ⓒ 5/16" Nut	

scale 1/2" = 1'







