

## SPECS AND INSTALL INSTRUCTIONS

### Square Expanded Metal Picnic Table with Bench Seats

SKU:

---

46" CF-8NVLR



#### Product maintenance

Inspect all hardware and fasteners, regularly check that all nuts and bolts are secure. Periodically examine for any signs of vandalism on any of your products thermoplastic surfaces. If any thermoplastic surface is vandalized by spray paint, simply take a rag and a aerosol can of WD40 ® and wipe the spray paint off. If the thermoplastic surface has any cuts simply take an industrial heat gun to the affected area. For regular cleaning use soap and water.

#### Thermoplastic Coating

Our outdoor furniture is covered in a copolymer-based thermoplastic powder coating. Thermoplastic is environmentally safe, the coating will never fade, crack, peel, warp, or discolor for the life of the product. Thermoplastic has the best adhesion rate of any other process. This keeps the metal base free of any corrosion possibilities. Thermoplastic is applied at a thickness of 25-30 mills. This allows maximum protection with the best possible surface. Thermoplastic can be easily repaired. Cuts are repaired by heating the affected area with an industrial heat gun. The thermoplastic will rebound itself. The properties of thermoplastic also make spray painting difficult for vandals. Simply wash product with a standard industrial cleaner.

#### Specifications

##### General

All seats and table tops of the listed products above are protected with Thermoplastic coating. Black powder coated galvanized steel legs and support structure. Available in expanded metal and perforated metals. Anti-skateboard tab is also available for all models above.

Check for any damaged or missing parts of if you have problems assembling your furniture / equipment please call our Customer Service Representatives.

# 46" Square Picnic Table w/Benches

Top view

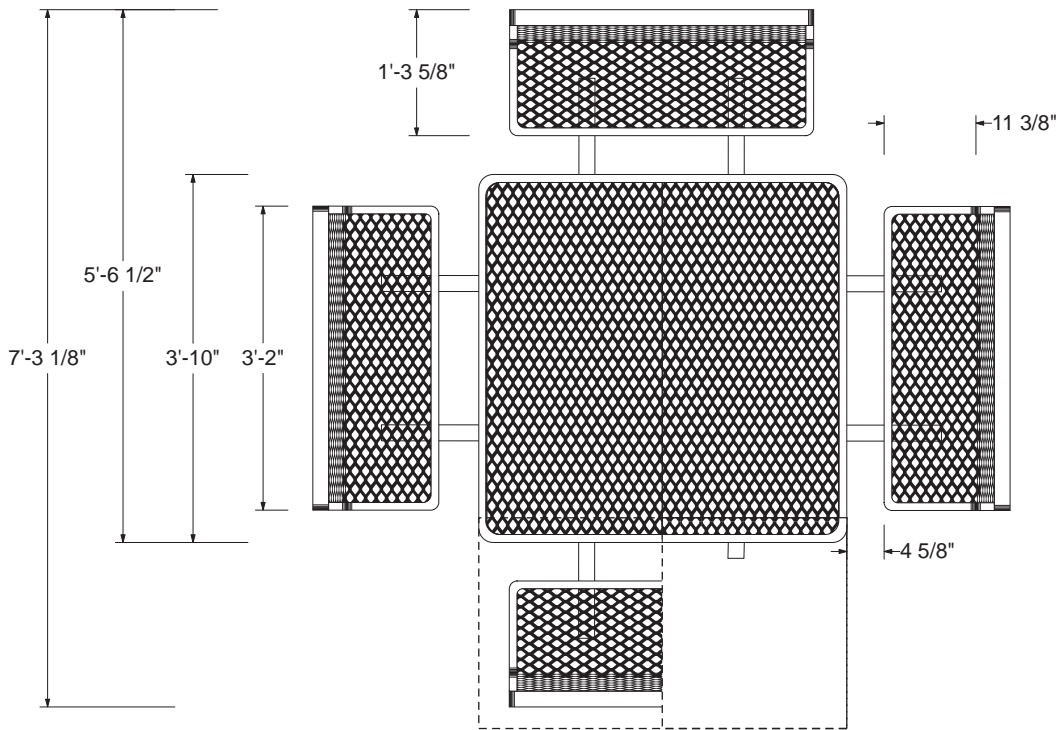

Side view

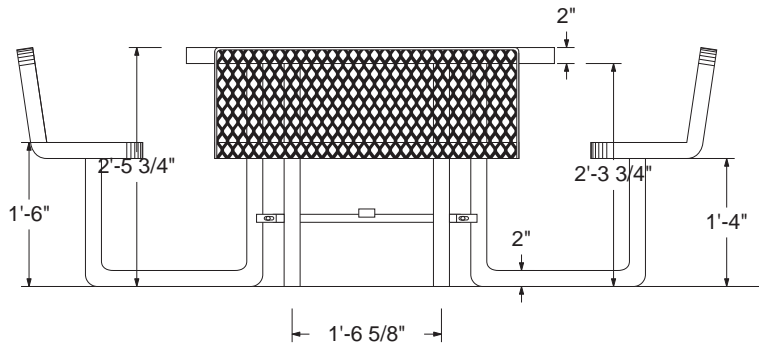

Available Styles

Quantities (per bench)

Hardware



Expanded Metal

1A - 5/16" Hex head bolts	- qty 28
1B - 5/16" Washer	- qty 56
1C - 5/16" Nut	- qty 28
2 - Bench seats (ADA -1 bench)	- qty 4
3 - Table top	- qty 1
4 - Leg	- qty 8
5 - Center brace	- qty 1

Ⓐ 5/16" Hex head bolt



Ⓑ 5/16" Washer



Ⓒ 5/16" Nut



scale 1/2" = 1'



