

CF-043-V7WTT

MODERN STYLE STACKING CHAIR WITH ARMS



Please take the time to locate and identify each part. Assemble the units on a smooth flat surface. It is also helpful to lay the tops and seats on cardboard or a drop cloth to prevent scratching of the surface during assembly. All parts have been pre-cut and pre-drilled for ease of assembly. All holes are slotted to allow for easy assembly and for final levelling of tops and seats to frames. Fully assembly all parts without totally tightening nuts and bolts. After all assembled go back and retighten nuts to bolts. **DO NOT OVER TIGHTEN NUTS TO BOLTS.** Over tightened nuts can crack the plastisol coating. All the necessary quantities of parts required are listed in this assembly instruction.

DO NOT BEGIN ASSEMBLY UNTIL YOU HAVE READ THESE INSTRUCTIONS AND ARE FAMILIAR WITH THE PARTS.

PARTS IDENTIFICATION

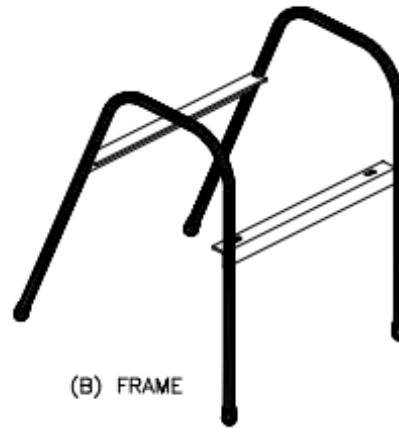
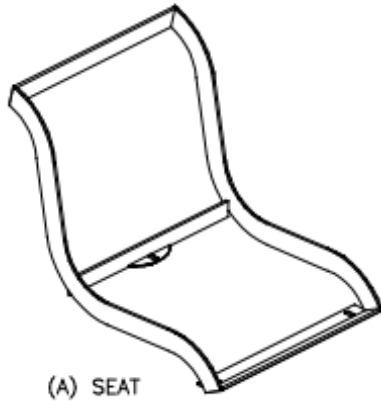

PARTS LIST

ITEM	PART#	DESCRIPTION	QTY.
A	SSTACKMOD	CHAIR SEAT	1
B	FSTACKCHAIR	CHAIR FRAME	1

ITEM	HARDWARE DESCRIPTION	QTY.
HW1	5/16" X 18 NYL LOCKNUTS	3
HW2	5/16" X 18GA CAP BOLTS	3
HW3	5/16" FLAT WASHERS	6
HW4	BOLT GUARDS	3

ASSEMBLY TOOLS REQUIRED
2- 1/2" WRENCHES

HARDWARE IDENTIFICATION



(HW1) 5/16" X 18
NYL LOCKNUTS

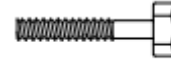

(HW2) 5/16" X 18
GAUGE CAP BOLTS



(HW3) 5/16"
FLAT WASHERS



(HW4) BOLT
GUARDS

ASSEMBLY PROCEDURES

STEP 1

SET THE SEAT ON TO THE FRAME MAKING SURE THE THREE HOLES LINE UP. FASTEN BY MEANS OF THREE 5/16" X 1 1/2" HEXBOLTS, SIX 5/16" FLAT WASHERS, AND THREE 5/16" NYLOCK NUTS.

STEP 2

TIGHTEN ALL NUTS ON ALL BOLTS AND PLACE THE BOLT GUARDS ON ALL NUTS. **DO NOT OVER TIGHTEN THE NUTS AS THIS COULD CAUSE THE PLASTISOL COATING TO CRACK.**

1	CAP. BOLT & WASHER
2	WASHER & LOCK NUT

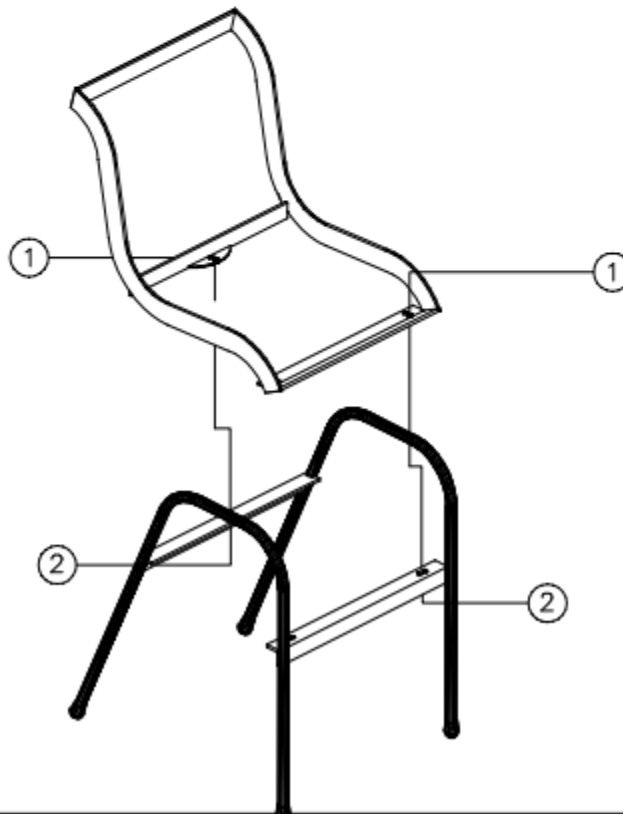

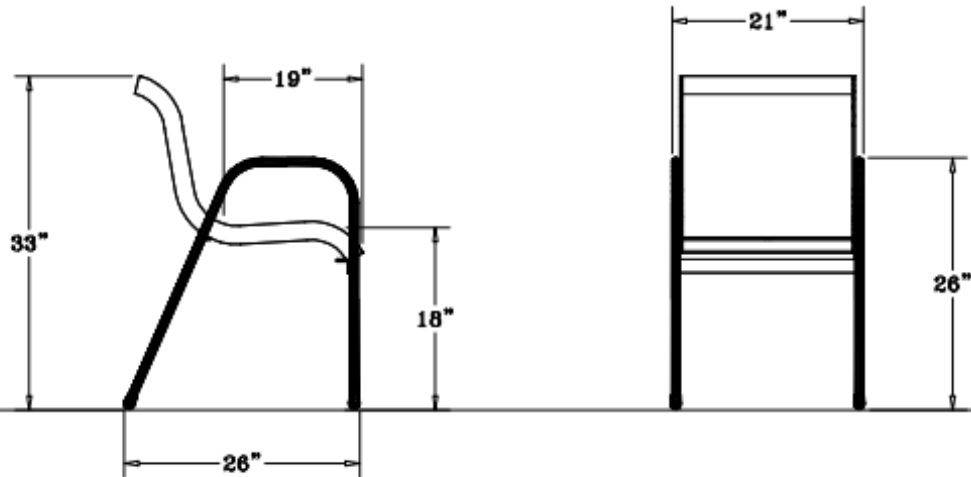

SPECIFICATIONS

33" X 21" POLY VINYL COATED MODERN STYLE STACKABLE CHAIR WITH ARMS.
THE FRAME IS PORTABLE DESIGN.

COATED WITH A 1/8" TO 1/4" THICK PLASTISOL ULTRAVIOLET STABILIZED VINYL COATING
FUSED AND BAKED TO A 90% GLOSS.

SEAT HEIGHT IS 18" APPROXIMATELY, CHAIR HEIGHT IS 33" APPROXIMATELY.
TOTAL OVERALL DIMENSIONS ARE 33" X 21".

SEAT IS MADE FROM HEAVY DUTY 3/4" #9 ROLLED EXPANDED METAL BORDERED WITH
1/8" X 1 1/2" FLAT STEEL.

FRAME IS MADE OF 7/8" ALUMINUM ROUNDS. COATED WITH A BAKED ON POLYESTER
POWDER COAT FINISH.

ALL HARDWARE IS NON-CORROSIVE.
WEIGHT FOR THE CSTACKMODERN IS 50 LBS.

MAINTENANCE

To maintain luster it is recommended to wash, rinse, and dry the units after prolonged use.
Check for loose bolts and nuts and tighten as needed. Contact the factory for genuine
Webcoat part replacements if needed.