

CF-043-QLBMC

2 SEAT DOWNTOWN STYLE BENCH WITH BACK SURFACE MOUNT DESIGN



Please take the time to locate and identify each part. Assemble the units on a smooth flat surface. It is also helpful to lay the tops and seats on cardboard or a drop cloth to prevent scratching of the surface during assembly. All parts have been pre-cut and pre-drilled for ease of assembly. All holes are slotted to allow for easy assembly and for final levelling of tops and seats to frames. Fully assembly all parts without totally tightening nuts and bolts. After all assembled go back and retighten nuts to bolts. **DO NOT OVER TIGHTEN NUTS TO BOLTS.** Over tightened nuts can crack the plastisol coating. All the necessary quantities of parts required are listed in this assembly instruction.

DO NOT BEGIN ASSEMBLY UNTIL YOU HAVE READ THESE INSTRUCTIONS AND ARE FAMILIAR WITH THE PARTS.

PARTS IDENTIFICATION

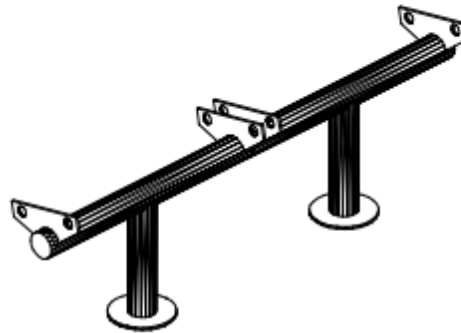

PARTS LIST

ITEM	PART#	DESCRIPTION	QTY.
ITEM ASWB0TS		SEAT W/BACK	2
ITEMB FBWB0TSSM		FRAME	1

ITEM	HARDWARE DESCRIPTION	QTY.
HW1	5/16" X 18 NYL LOCKNUTS	8
HW2	5/16" X 18GA CAP BOLTS	8
HW3	5/16" FLAT WASHERS	16
HW4	BOLT GUARDS	8

ASSEMBLY TOOLS REQUIRED
2- 1/2" WRENCHES

HARDWARE IDENTIFICATION



(HW1) 5/16" X 18
NYL LOCKNUTS



(HW2) 5/16" X 18
GAUGE CAP BOLTS



(HW3) 5/16"
FLAT WASHERS



(HW4) BOLT
GUARDS

ASSEMBLY PROCEDURES

STEP 1

MOUNT THE COATED FORMED SEAT TO THE FRAME BY MEANS OF FOUR 5/16" X 1 1/2" HEXBOLTS, EIGHT 5/16" FLAT WASHERS, AND FOUR NYLOCK NUTS PER SEAT, THROUGH THE SLOTTED HOLES ON THE FRAME AND THROUGH THE SLOTTED HOLES ON THE SEATS.

STEP 2

CAREFULLY SIT SEATS UPRIGHT AND MOUNT TO A SMOOTH LEVEL SURFACE.
SURFACE MOUNTING HARDWARE NOT INCLUDED.

STEP 3

TIGHTEN ALL NUTS ON ALL BOLTS AND PLACE THE BOLT GUARDS ON ALL NUTS. **DO NOT OVER TIGHTEN THE NUTS AS THIS COULD CAUSE THE PLASTISOL COATING TO CRACK.**

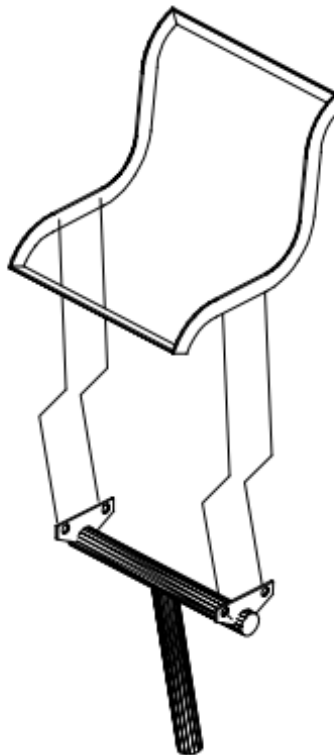

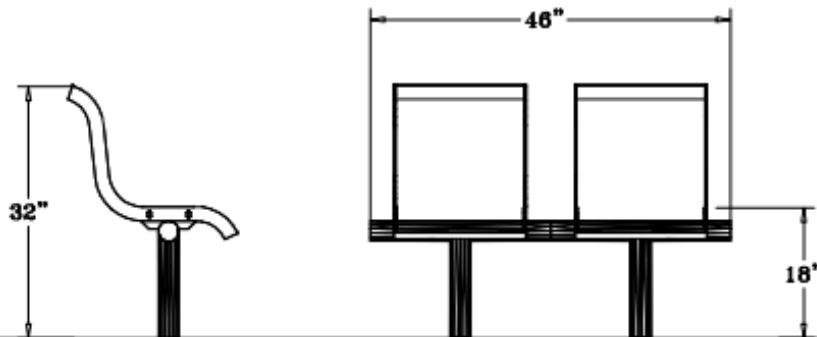

SPECIFICATIONS

46" X 26 1/2" POLY VINYL COATED EXPANDED METAL DOWNTOWN BENCH WITH BACK. ALL CORNERS ARE ROUNDED. FRAME IS SURFACE MOUNT DESIGN.

COATED WITH A 1/8" TO 1/4" THICK PLASTISOL ULTRAVIOLET STABILIZED VINYL COATING FUSED AND BAKED TO A 90% GLOSS.

SEAT HEIGHT IS 18" APPROXIMATELY, BENCH HEIGHT IS 32" APPROXIMATELY. TOTAL OVERALL DIMENSIONS ARE 46" X 26 1/2" APPROXIMATELY.

SEATS ARE MADE FROM 3/4" #9 EXPANDED METAL INSIDE A 2" X 2" X 1/8" ANGLE IRON FRAME. ALL CENTER BRACES ARE MADE FROM 1/8" FLAT STEEL.

FRAMES ARE MADE OF 2 3/8" HEAVY GALVANIZED STEEL TUBING THAT IS GALVANIZED INSIDE AND OUT AND MEETS OR EXCEEDS YIELD AND TENSILE OF SCH. 40 PIPE. CONSTRUCTED SO AS TO PROHIBIT RAIN WATER FROM COLLECTING AT GROUND LEVEL. COATED WITH A BAKED ON POLYESTER POWDER COAT FINISH.

ALL HARDWARE IS NON-CORROSIVE.
WEIGHT FOR THE BWBDS2SM IS 125 LBS.

MAINTENANCE

To maintain luster it is recommended to wash, rinse, and dry the units after prolonged use. Check for loose bolts and nuts and tighten as needed. Contact the factory for genuine Webcoat part replacements if needed.

