

## CF-043-G3PDA

2 SEAT DOWNTOWN STYLE CLASSIC BENCH SURFACE MOUNT DESIGN



Please take the time to locate and identify each part. Assemble the units on a smooth flat surface. It is also helpful to lay the tops and seats on cardboard or a drop cloth to prevent scratching of the surface during assembly. All parts have been pre-cut and pre-drilled for ease of assembly. All holes are slotted to allow for easy assembly and for final levelling of tops and seats to frames. Fully assembly all parts without totally tightening nuts and bolts. After all assembled go back and retighten nuts to bolts. **DO NOT OVER TIGHTEN NUTS TO BOLTS.** Over tightened nuts can crack the plastisol coating. All the necessary quantities of parts required are listed in this assembly instruction.

**DO NOT BEGIN ASSEMBLY UNTIL YOU HAVE READ THESE INSTRUCTIONS AND ARE FAMILIAR WITH THE PARTS.**

## PARTS IDENTIFICATION



(A) SLINE DT CLASSIC SEAT

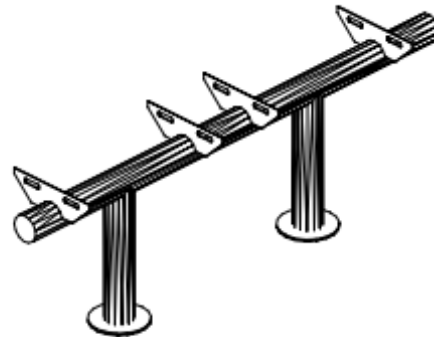

(B) SLINE FRAME

## PARTS LIST

ITEM	PART#	DESCRIPTION	QTY.
A	SDTSCLAS	SLINE CLASSIC SEAT	2
B	FDTSSM	SLINE FRAME	1

ITEM	HARDWARE DESCRIPTION	QTY.
HW1	5/16" X 18 NYL LOCKNUTS	6
HW2	5/16" X 18GA CAP BOLTS	6
HW3	5/16" FLAT WASHERS	16
HW4	BOLT GUARDS	6

**ASSEMBLY TOOLS REQUIRED**  
2- 1/2" WRENCHES

## HARDWARE IDENTIFICATION



(HW1) 5/16" X 18  
NYL LOCKNUTS



(HW2) 5/16" X 18  
GAUGE CAP BOLTS



(HW3) 5/16"  
FLAT WASHERS



(HW4) BOLT  
GUARDS

## ASSEMBLY PROCEDURES

### STEP 1

MOUNT FRAME TO SMOOTH LEVEL SURFACE.  
SURFACE MOUNTING HARDWARE IS NOT INCLUDED.

### STEP 2

MOUNT THE SEAT BY MEANS OF EIGHT 5/16" X 1 1/2" HEXBOLTS, SIXTEEN 5/16" FLAT WASHERS, AND EIGHT 5/16" NYLOCK NUTS THROUGH THE SLOTTED HOLES ON THE SEAT AND THROUGH THE SLOTTED HOLES ON THE ANGLE IRON OF THE FRAMES.

### STEP 3

TIGHTEN ALL NUTS ON ALL BOLTS AND PLACE THE BOLT GUARDS ON ALL NUTS. DO NOT OVER TIGHTEN THE NUTS AS THIS COULD CAUSE THE PLASTISOL COATING TO CRACK.

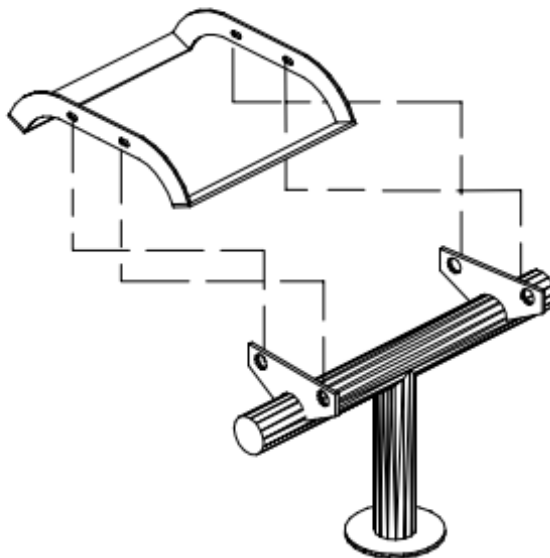

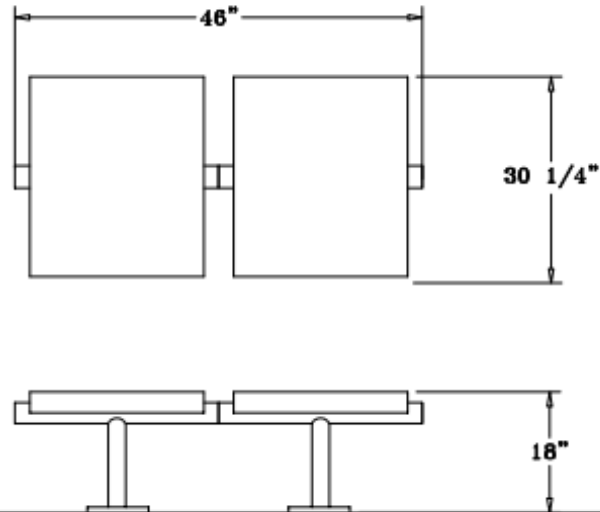

### SPECIFICATIONS

2 SEAT POLY VINYL COATED RIBBED STEEL DOWNTOWN STYLE BENCH.  
THE FRAME IS SURFACE MOUNT DESIGN.

COATED WITH A 1/8" TO 1/4" THICK PLASTISOL ULTRAVIOLET STABILIZED VINYL COATING  
FUSED AND BAKED TO A 90% GLOSS

SEAT HEIGHT IS 18" APPROXIMATELY. OVERALL DIMENSIONS ARE 46" X 30 1/4".

SEAT IS MADE FROM 11GA. SOLID CUT OUT METAL. END BRACES ARE  
MADE FROM 1 1/4" X 1/8" FLAT STEEL.

FRAME IS A 2 7/8" HEAVY DUTY GALVANIZED STEEL TUBING THAT IS GALVANIZED INSIDE  
AND OUT AND MEETS OR EXCEEDS THE YIELD AND TENSIAL OF SCH 40 PIPE. CONSTRUCTED SO AS  
TO PROHIBIT RAIN WATER FROM COLLECTING AT GROUND LEVEL. COATED WITH A BAKED ON  
POLYESTER POWDER COAT FINISH.

ALL HARDWARE IS NON-CORROSIVE.  
WEIGHT FOR THE BDTCLASSS2SM IS 105 LBS.

### MAINTENANCE

To maintain luster it is recommended to wash, rinse, and dry the units after prolonged use.  
Check for loose bolts and nuts and tighten as needed. Contact the factory for genuine  
Webcoat part replacements if needed.