

## CF-043-YWNFS

6' PERFORATED STYLE BENCH WITH BACK INGROUND MOUNT PEDISTAL DESIGN

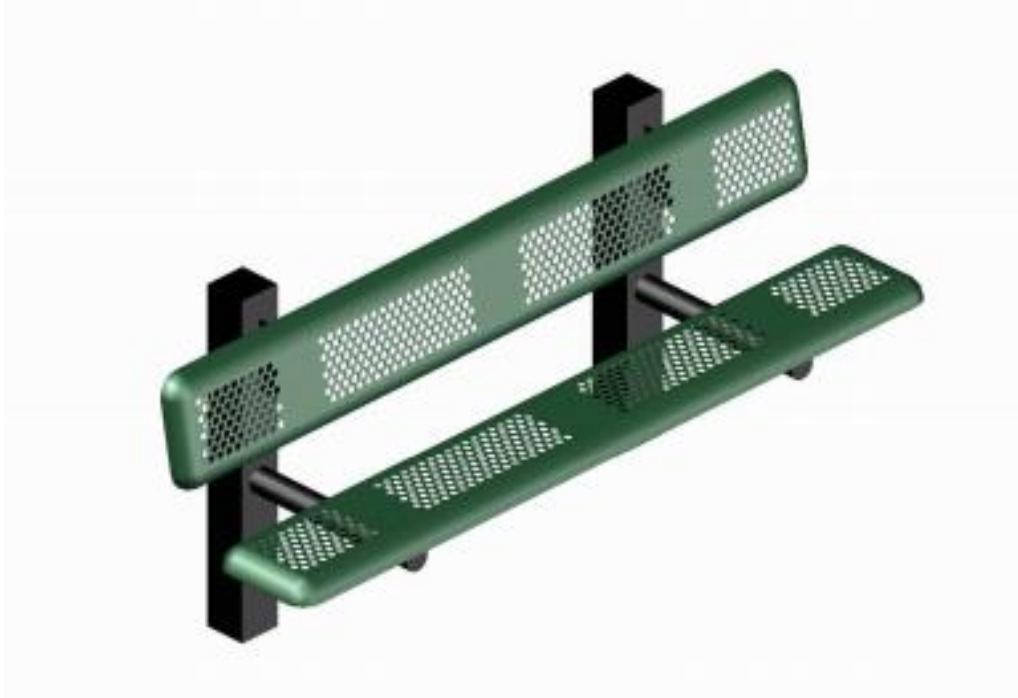

Please take the time to locate and identify each part. Assemble the units on a smooth flat surface. It is also helpful to lay the tops and seats on cardboard or a drop cloth to prevent scratching of the surface during assembly. All parts have been pre-cut and pre-drilled for ease of assembly. All holes are slotted to allow for easy assembly and for final levelling of tops and seats to frames. Fully assembly all parts without totally tightening nuts and bolts. After all assembled go back and retighten nuts to bolts. **DO NOT OVER TIGHTEN NUTS TO BOLTS.** Over tightened nuts can crack the plastisol coating. All the necessary quantities of parts required are listed in this assembly instruction.

**DO NOT BEGIN ASSEMBLY UNTIL YOU HAVE READ THESE INSTRUCTIONS AND ARE FAMILIAR WITH THE PARTS.**

## PARTS IDENTIFICATION

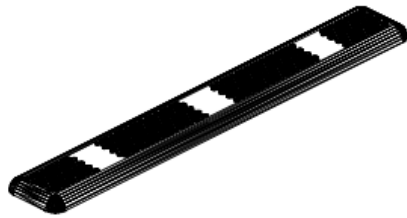

(A) 6' PERF SEAT

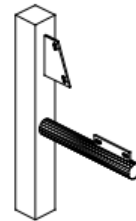

(B) BENCH FRAME

## PARTS LIST

| ITEM | PART#  | DESCRIPTION        | QTY. |
|------|--------|--------------------|------|
| A    | S6PERF | 6' PERF SEAT       | 2    |
| B    | FBSWBI | BENCH FRAME W/BACK | 2    |

| ITEM | HARDWARE DESCRIPTION    | QTY. |
|------|-------------------------|------|
| HW1  | 5/16" X 18 NYL LOCKNUTS | 8    |
| HW2  | 5/16" X 18GA CAP BOLTS  | 8    |
| HW3  | 5/16" FLAT WASHERS      | 16   |
| HW4  | BOLT GUARDS             | 8    |

ASSEMBLY TOOLS REQUIRED  
2- 1/2" WRENCHES

## HARDWARE IDENTIFICATION



(HW1) 5/16" X 18  
NYL LOCKNUTS



(HW2) 5/16" X 18  
GAUGE CAP BOLTS



(HW3) 5/16"  
FLAT WASHERS



(HW4) BOLT  
GUARDS

## ASSEMBLY PROCEDURES

### STEP 1

MOUNT THE SEATS BY MEANS OF FOUR 5/16" X 1 1/2" HEXBOLTS, EIGHT 5/16" FLAT WASHERS, AND FOUR 5/16" NYLOCK NUTS, PER SEAT, THROUGH THE SLOTTED HOLES ON THE SEATS AND THROUGH THE SLOTTED HOLES ON THE ANGLE IRON OF THE FRAMES. **HAND TIGHTEN ONLY AT THIS TIME.**

### STEP 2

REPEAT ABOVE STEP FOR BACKS.

### STEP 3

FOLLOWING THE FOOTING DIAGRAM BELOW, DIG TWO IN LINE HOLES APPROXIMATELY 24" DEEP BY 12" ROUND.

### STEP 4

SET THE BENCH END FRAMES IN HOLES ON THE SAME CENTER DISTANCE AS THE HOLES. MAKE SURE THE BENCH FRAMES ARE 18" ABOVE GROUND LEVEL AND ARE IN LINE. PLUMB THE FRAMES AND FILL WITH CONCRETE. **LET STAND FOR 24 HOURS BEFORE COMPLETING THESE ASSEMBLY INSTRUCTIONS.**

### STEP 5

TIGHTEN ALL NUTS ON ALL BOLTS AND PLACE THE BOLT GUARDS ON ALL NUTS. **DO NOT OVER TIGHTEN THE NUTS AS THIS COULD CAUSE THE PLASTISOL COATING TO CRACK.**

FOOTING DIAGRAM:

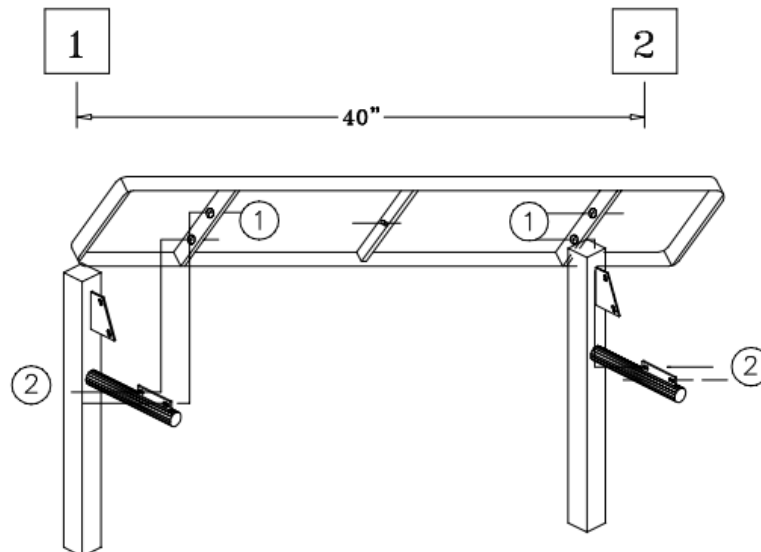

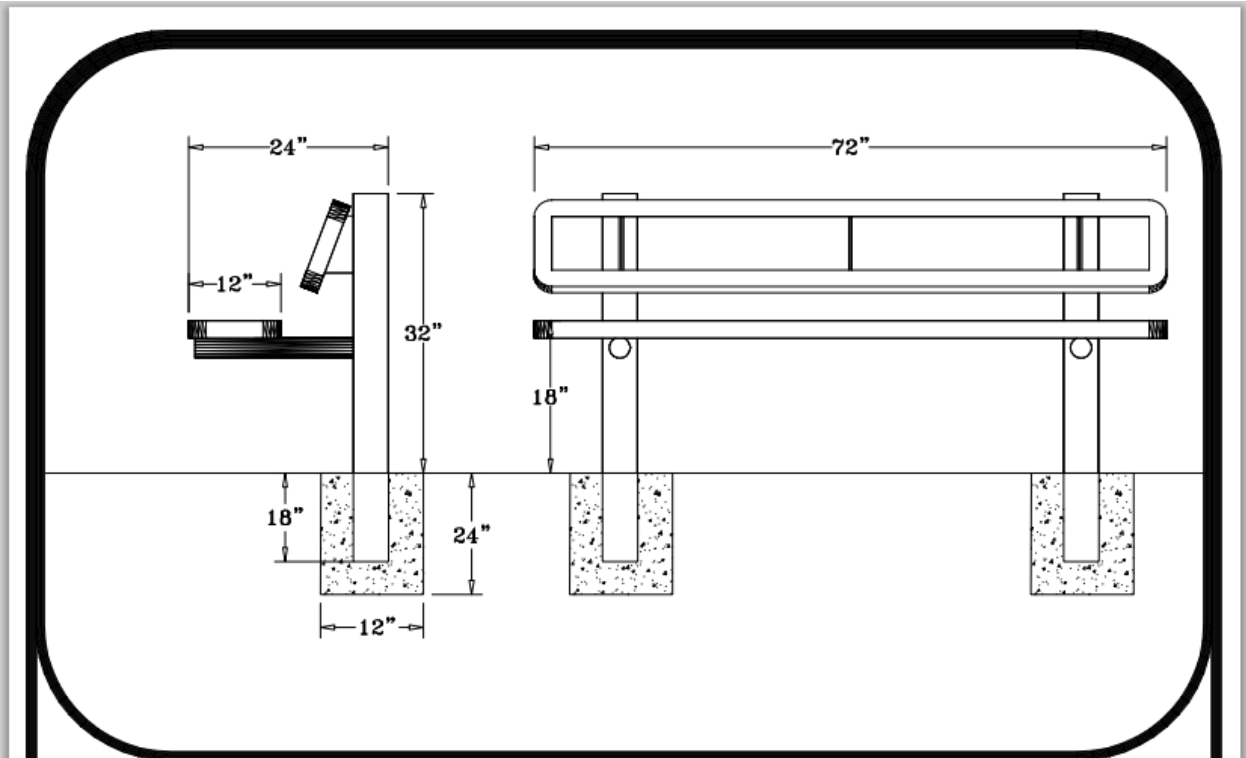

## SPECIFICATIONS

6' POLY VINYL COATED 11GA. PUNCHED STEEL BENCH.  
ALL EDGES AND CORNERS ARE ROLLED. FRAME IS INGROUND MOUNT DESIGN.  
COATED WITH A 1/8" TO 1/4" THICK PLASTISOL ULTRAVIOLET STABILIZED VINYL COATING FUSED AND BAKED TO A 90% GLOSS.  
SEAT HEIGHT IS 18" APPROXIMATELY. TOTAL OVERALL DIMENSIONS ARE 72" X 21".  
SEAT IS MADE FROM FLAT STEEL WITH 11GA. PRECISION PUNCHED ROUND HOLES WITH A 3/4" DIA. ALL EDGED ARE ROLLED TO A 2" DIA. TO FORM A ROUNDED EDGE FOR SMOOTHNESS AND SAFETY. A 1/4" X 1 1/2" STEEL BRACING IS WELDED TO THE UNDERSIDE FOR ADDED SUPPORT.  
FRAME IS HEAVY GALVANIZED STEEL 4" X 4" SQUARE TUBING THAT IS GALVANIZED ON THE INSIDE AND OUT AND MEETS OR EXCEEDS THE YIELD AND TENSILE OF SCH 40 PIPE. CONSTRUCTED SO AS TO PROHIBIT RAIN WATER FROM COLLECTING AT GROUND LEVEL. COATED WITH A BAKED ON POLYESTER POWDER COAT FINISH.

ALL HARDWARE IS NON-CORROSIVE.  
WEIGHT FOR THE B6WBPERF4-4S IS 176 LBS.

## MAINTENANCE

To maintain luster it is recommended to wash, rinse, and dry the units after prolonged use. Check for loose bolts and nuts and tighten as needed. Contact the factory for genuine Webcoat part replacements if needed.