

CF-043-CAEBG

6' PERFORATED STYLE BENCH PORTABLE MOUNT DESIGN



Please take the time to locate and identify each part. Assemble the units on a smooth flat surface. It is also helpful to lay the tops and seats on cardboard or a drop cloth to prevent scratching of the surface during assembly. All parts have been pre-cut and pre-drilled for ease of assembly. All holes are slotted to allow for easy assembly and for final levelling of tops and seats to frames. Fully assemble all parts without totally tightening nuts and bolts. After all assembled go back and retighten nuts to bolts. **DO NOT OVER TIGHTEN NUTS TO BOLTS.** Over tightening nuts can crack the Plastisol coating. All the necessary quantities of parts required are listed in these assembly instructions.

DO NOT BEGIN ASSEMBLY UNTIL YOU HAVE READ THESE INSTRUCTIONS AND ARE FAMILIAR WITH THE PARTS.

PARTS IDENTIFICATION

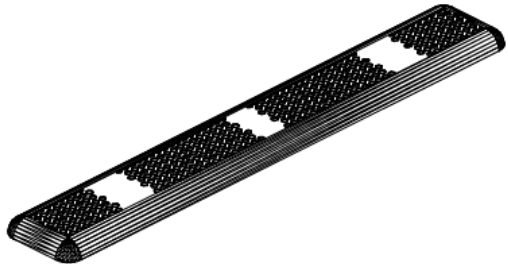

(A) 6' PERF SEAT



(B) BENCH FRAME



(C) DIAGONAL

PARTS LIST

ITEM	PART#	DESCRIPTION	QTY.
A	S6PERF	6' PERF SEAT	1
B	FBP	BENCH FRAME	2
C	D6PERF	DIAGONAL	2

ITEM	HARDWARE DESCRIPTION	QTY.
HW1	5/16" X 18 NYL LOCKNUTS	7
HW2	5/16" X 18GA CAP BOLTS	7
HW3	5/16" FLAT WASHERS	14
HW4	BOLT GUARDS	7

ASSEMBLY TOOLS REQUIRED
2- 1/2" WRENCHES

HARDWARE IDENTIFICATION



(HW1) 5/16" X 18 NYL LOCKNUTS



(HW2) 5/16" X 18 GAUGE CAP BOLTS



(HW3) 5/16" FLAT WASHERS



(HW4) BOLT GUARDS

ASSEMBLY PROCEDURES

STEP 1

LAY BENCH SEAT UPSIDE DOWN ON A SMOOTH FLAT SURFACE.
ATTACH FRAMES TO SEAT BY MEANS OF FOUR 5/16" X 1 1/2" HEXBOLTS,
EIGHT 5/16" FLAT WASHERS AND FOUR 5/16" NYLOCK NUTS THROUGH THE SLOTTED HOLES
ON THE SEATS AND THROUGH THE SLOTTED HOLES ON ANGLE IRON OF FRAME ENDS.
Hand tighten only at this time.

STEP 2

CAREFULLY SET BENCH UPRIGHT ON SMOOTH LEVEL SURFACE AND LEVEL BENCH.
TIGHTEN ALL NUTS ON ALL BOLTS AND PLACE THE BOLT GUARDS ON ALL NUTS. **DO NOT
OVER TIGHTEN THE NUTS AS THIS COULD CAUSE THE PLASTISOL COATING TO CRACK.**



ANGLE BOLTS TO INSIDE OF BRACE, FACING EACH OTHER.

1	CAP BOLT & WASHER
2	WASHER & LOCKNUT

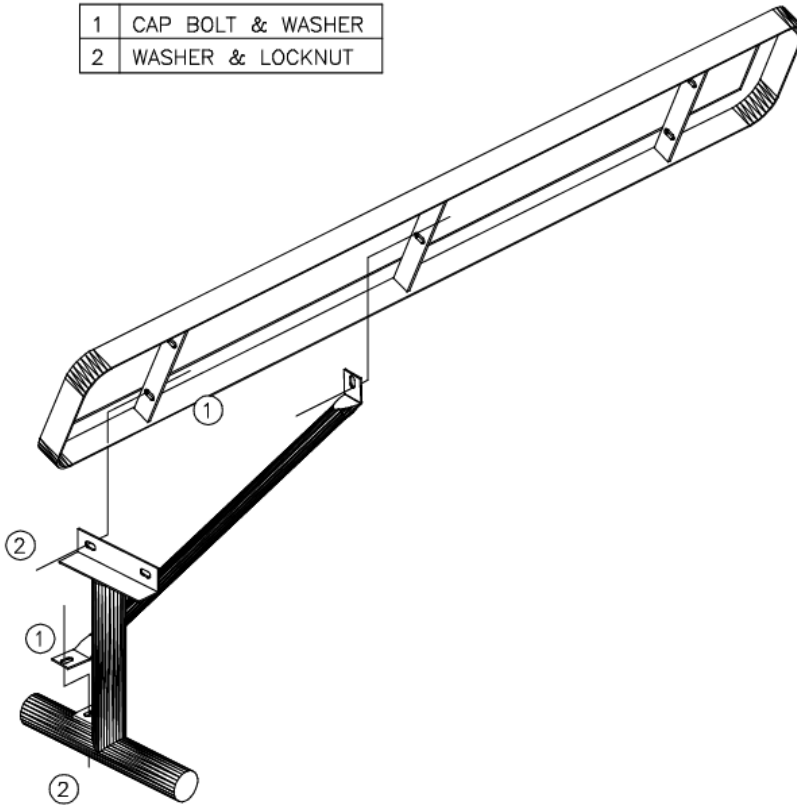

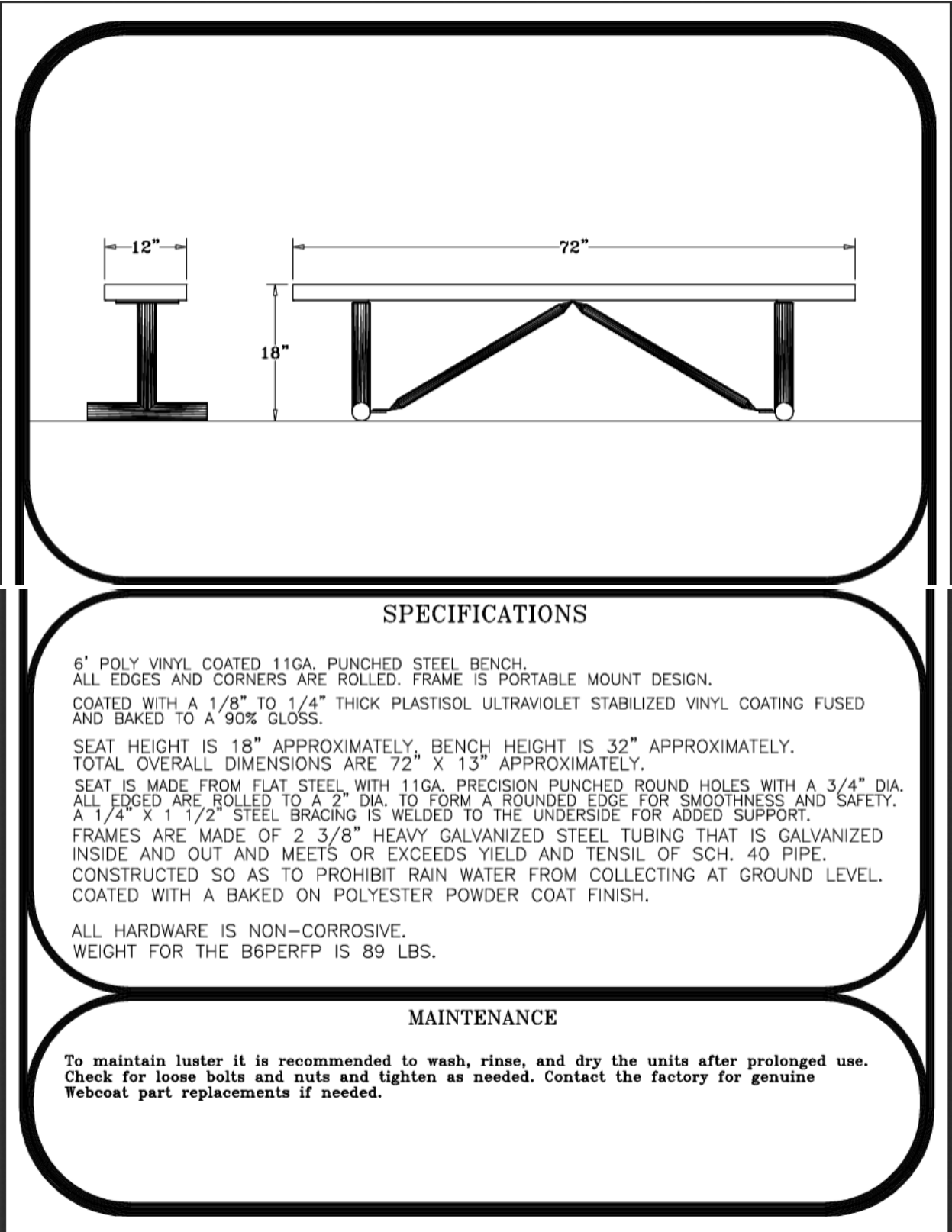

SPECIFICATIONS

6' POLY VINYL COATED 11GA. PUNCHED STEEL BENCH.
ALL EDGES AND CORNERS ARE ROLLED. FRAME IS PORTABLE MOUNT DESIGN.
COATED WITH A 1/8" TO 1/4" THICK PLASTISOL ULTRAVIOLET STABILIZED VINYL COATING FUSED
AND BAKED TO A 90% GLOSS.

SEAT HEIGHT IS 18" APPROXIMATELY, BENCH HEIGHT IS 32" APPROXIMATELY.
TOTAL OVERALL DIMENSIONS ARE 72" X 13" APPROXIMATELY.

SEAT IS MADE FROM FLAT STEEL WITH 11GA. PRECISION PUNCHED ROUND HOLES WITH A 3/4" DIA.
ALL EDGED ARE ROLLED TO A 2" DIA. TO FORM A ROUNDED EDGE FOR SMOOTHNESS AND SAFETY.
A 1/4" X 1 1/2" STEEL BRACING IS WELDED TO THE UNDERSIDE FOR ADDED SUPPORT.

FRAMES ARE MADE OF 2 3/8" HEAVY GALVANIZED STEEL TUBING THAT IS GALVANIZED
INSIDE AND OUT AND MEETS OR EXCEEDS YIELD AND TENSIL OF SCH. 40 PIPE.
CONSTRUCTED SO AS TO PROHIBIT RAIN WATER FROM COLLECTING AT GROUND LEVEL.
COATED WITH A BAKED ON POLYESTER POWDER COAT FINISH.

ALL HARDWARE IS NON-CORROSIVE.
WEIGHT FOR THE B6PERFP IS 89 LBS.

MAINTENANCE

To maintain luster it is recommended to wash, rinse, and dry the units after prolonged use.
Check for loose bolts and nuts and tighten as needed. Contact the factory for genuine
Webcoat part replacements if needed.