

## SPECS AND INSTALL INSTRUCTIONS

### Oglethorpe & Northgate Welded Ribbon Park Bench



#### Product maintenance

Inspect all hardware and fasteners, regularly check that all nuts and bolts are secure. Periodically examine for any signs of vandalism on any of your products thermoplastic surfaces. If any thermoplastic surface is vandalized by spray paint, simple take a rag and a aerosol can of WD40 ® and wipe the spray paint off. If the thermoplastic surface has any cuts simple take an industrial heat gun to the affected area. For regular cleaning use soap and water.

#### Thermoplastic Coating

Our outdoor furniture is covered in a copolymer-based thermoplastic powder coating. Thermoplastic is environmentally safe, the coating will never fade, crack, peel, warp, or discolor for the life of the product. Thermoplastic has the best adhesion rate of any other process. This keeps the metal base free of any corrosion possibilities. Thermoplastic is applied at a thickness of 25-30 mills. This allows maximum protection with the best possible surface. Thermoplastic can be easily repaired. Cuts are repaired by heating the affected area with an industrial heat gun. The thermoplastic will rebound itself. The properties of thermoplastic also make spray painting difficult for vandals. Simply wash product with a standard industrial cleaner.

#### Specifications

##### General

All of the listed products above are protected with Thermoplastic coating. Predrilled holes for surface mounting. Cast iron legs. 1 1/4" steel seat straps. The Oglethorpe is styled with a straight back, while the Northgate is styled with an arched back. Both the Oglethorpe and the Northgate seat straps are individually cut, bent and welded.

Check for any damaged or missing parts or if you have problems assembling your furniture / equipment please call our customer service center.



## Northgate Bench and Chair

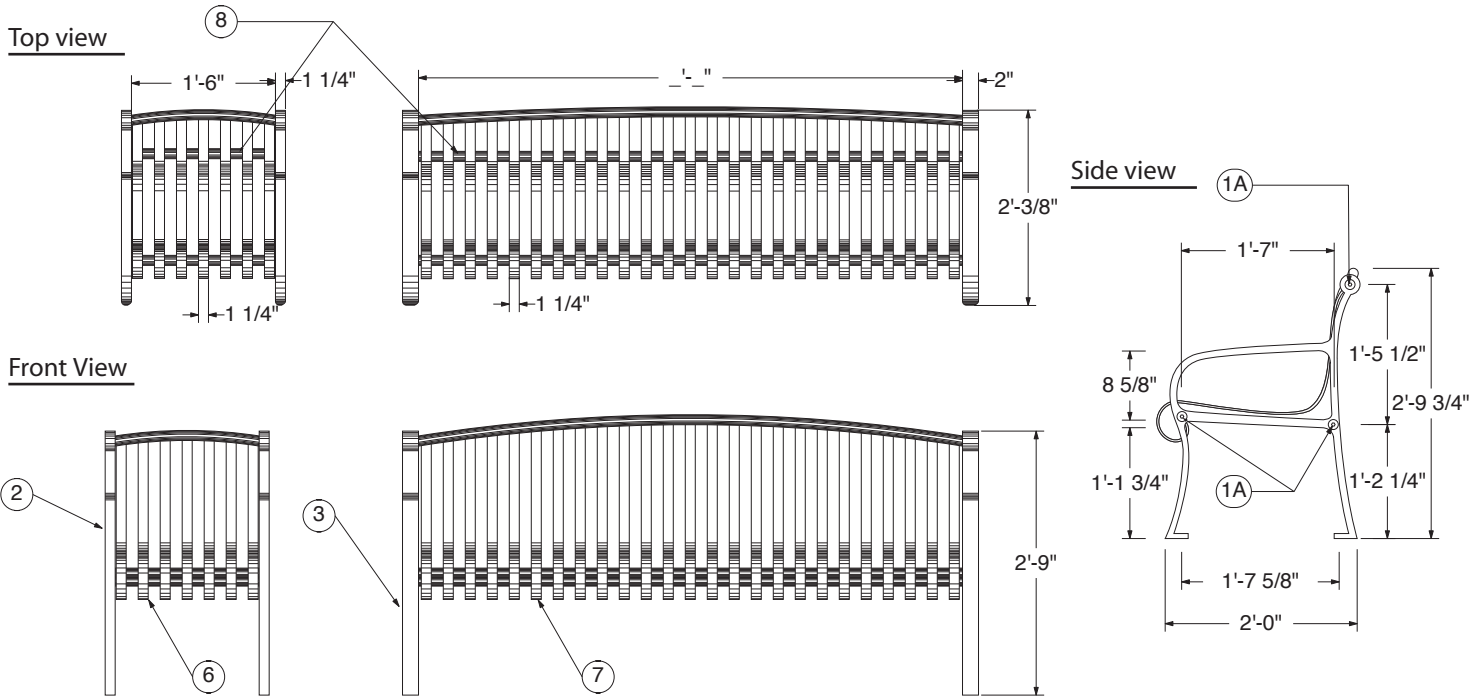

## Oglethorpe Bench and Chair

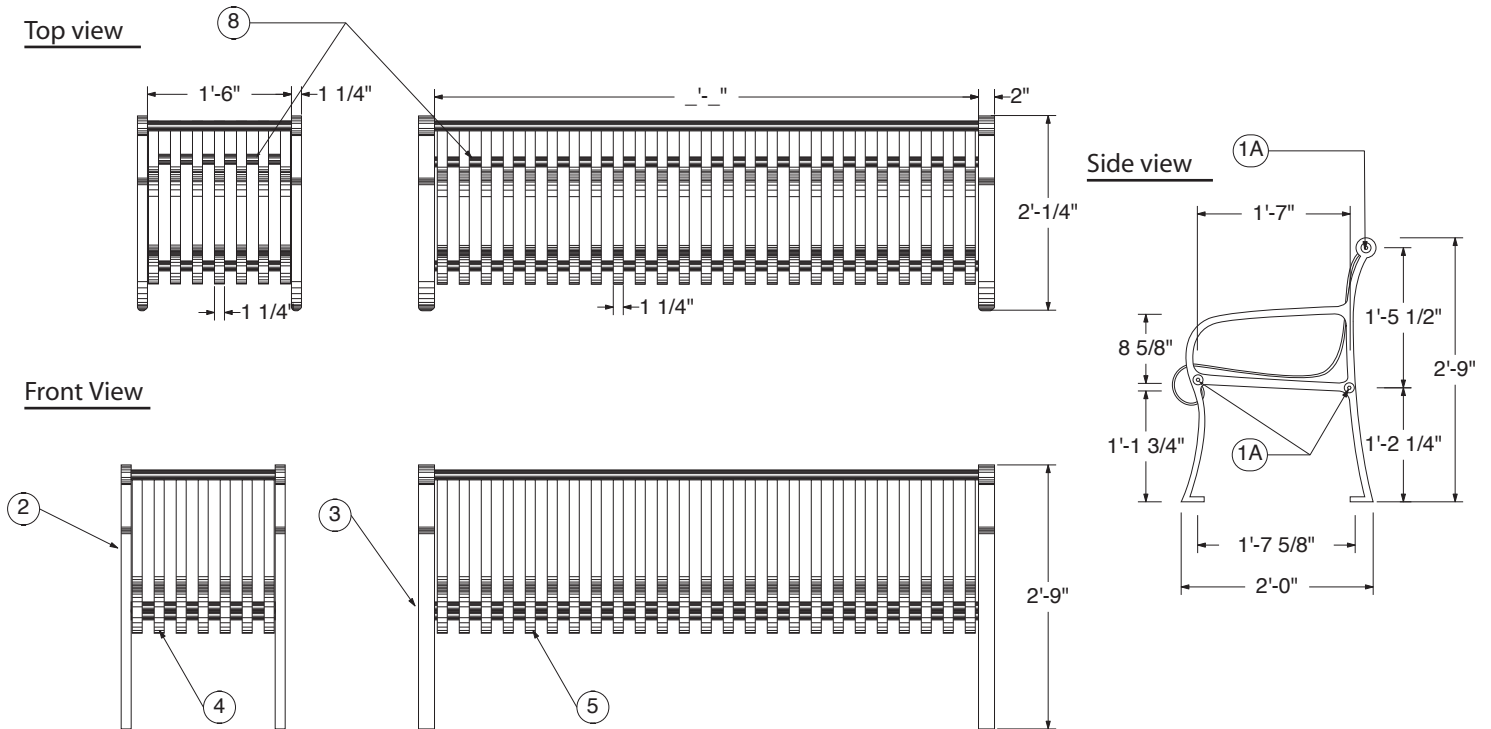

### Available Styles

### Quantities (per bench)

### Hardware

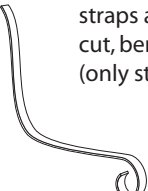
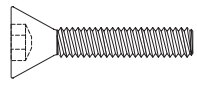
 <p>straps are individually cut, bent and welded (only style)</p>	<table border="0"> <tr> <td>1A - Machine Bolt</td> <td>- qty 6</td> </tr> <tr> <td>2 - NG and OG chair legs</td> <td>- qty 2</td> </tr> <tr> <td>3 - NG and OG bench legs</td> <td>- qty 2</td> </tr> <tr> <td>4 - Oglethorpe chair seat</td> <td>- qty 1</td> </tr> <tr> <td>5 - Oglethorpe bench seat</td> <td>- qty 1</td> </tr> <tr> <td>6 - Northgate chair seat</td> <td>- qty 1</td> </tr> <tr> <td>7 - Northgate bench seat</td> <td>- qty 1</td> </tr> <tr> <td>8 - Rear Brace</td> <td>- qty 1</td> </tr> </table>	1A - Machine Bolt	- qty 6	2 - NG and OG chair legs	- qty 2	3 - NG and OG bench legs	- qty 2	4 - Oglethorpe chair seat	- qty 1	5 - Oglethorpe bench seat	- qty 1	6 - Northgate chair seat	- qty 1	7 - Northgate bench seat	- qty 1	8 - Rear Brace	- qty 1	<p>Ⓐ Taperd Hex Head Bolt</p> 
1A - Machine Bolt	- qty 6																	
2 - NG and OG chair legs	- qty 2																	
3 - NG and OG bench legs	- qty 2																	
4 - Oglethorpe chair seat	- qty 1																	
5 - Oglethorpe bench seat	- qty 1																	
6 - Northgate chair seat	- qty 1																	
7 - Northgate bench seat	- qty 1																	
8 - Rear Brace	- qty 1																	

scale 1/2" = 1'



# Assembly Instructions

---

Oglethorpe Chair  
Oglethorpe Bench  
Northgate Chair  
Northgate Bench

Note: Work 1 one side at a time.  
Do not tightly secure bolts until product is fully assembled.

---

## Step 1:

Check that all hardware, legs, and seats are accounted for. Total parts for the assembly of one bench or chair equals two legs, one seat, one rear brace rod, and six Tapered Hex Head Bolts.

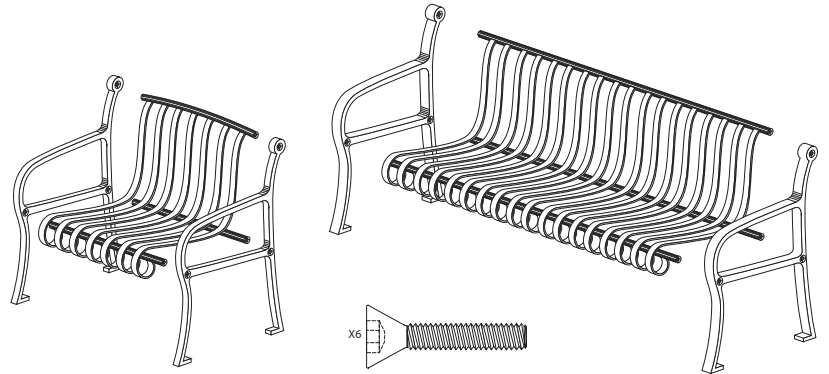

## Step 2A:

Assembly of both the bench and the chair are the same. Take the seat and flip it upside down, then take one leg at a time and attach the top bolt then the bottom bolt of the seat. With out tightening any of the bolts, continue onto the other leg and attach the bolts at the top and the bottom of the seat. Now take the rear brace rod and attach it to both of the legs.

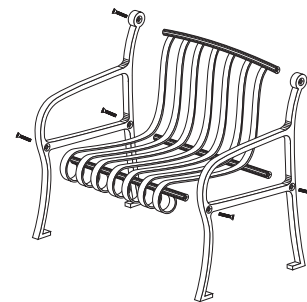

*(To prevent damage to your bench  
place a blanket underneath the bench.)*

---

## Step 3:

After all bolts are in place flip bench on its feet. Then Tighten all of the bolts in the same progression that you started with. After all bolts are tightened enjoy your new bench.

