

## SPECS AND INSTALL INSTRUCTIONS

### Armless Steel Rod Bench

SKU:

---

4' CF-PY4CY      6' CF-G1M8Z

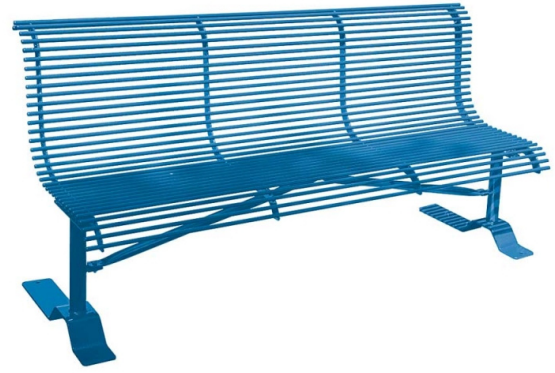

### Thermoplastic Coating

Our outdoor furniture is covered in a copolymer-based thermoplastic powder coating. Thermoplastic is environmentally safe, the coating will never fade, crack, peel, warp, or discolor for the life of the product. Thermoplastic has the best adhesion rate of any other process. This keeps the metal base free of any corrosion possibilities. Thermoplastic is applied at a thickness of 25-30 mills. This allows maximum protection with the best possible surface. Thermoplastic can be easily repaired. Cuts are repaired by heating the affected area with an industrial heat gun. The thermoplastic will rebound itself. The properties of thermoplastic also make spray painting difficult for vandals. Simply wash product with a standard industrial cleaner.

### Specifications

#### General

Bench seat of the listed product above are protected with Thermoplastic coating. 1/2" Welded ssteel rod and pre-drilled mounting holes.

Check for any damaged or missing parts of if you have problems assembling your furniture / equipment please call our Customer Service Representatives.

# Standard Metal Bench with Back

Top view

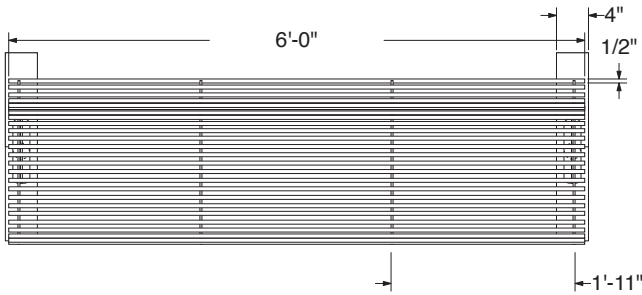

ISO

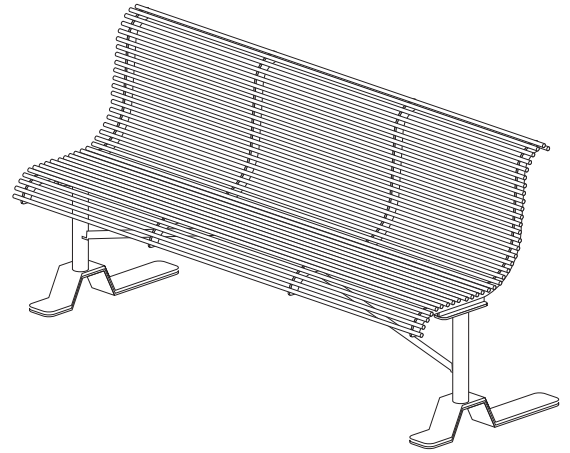

Front View

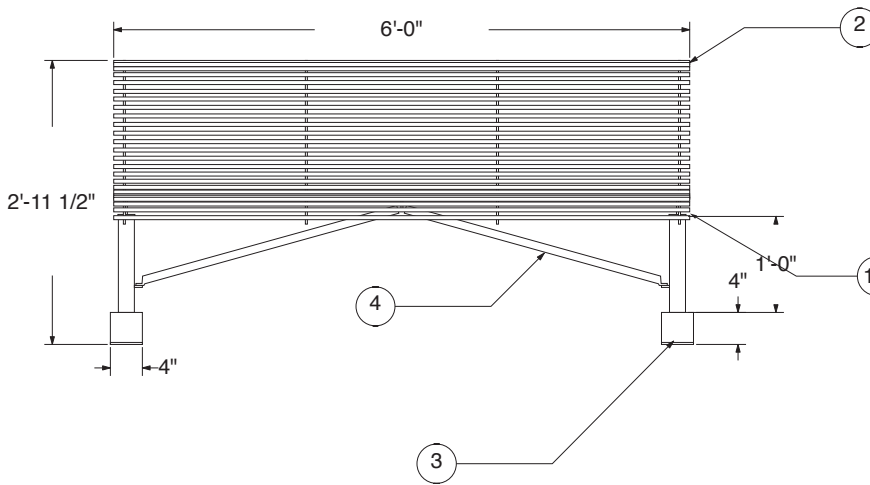



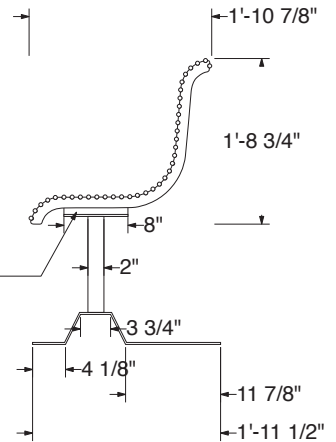

Side view



Available Styles

Quantities (per bench)

Hardware

 Steel Rod	1A - 5/16" Hex head bolts - qty 5 1B - 5/16" Washer - qty 10 1C - 5/16" Nut - qty 5 2 - Bench Seat - qty 1 3 - Legs - qty 2 4 - Supports - qty 2	(A) 5/16" Hex head  (B) 5/16" Washer  (C) 5/16" Nut 
---	---	---

scale 1/2" = 1'



# Assembly Instructions

---

## Rod Bench

Note: Work 1 one side at a time.

Do not tightly secure bolts until product is fully assembled.

---

### Step 1:

Check that all hardware, legs, and seats are accounted for. Total parts for the assembly of one rod bench. Two legs, one bench seat, two brace rod, five 5/16" Hex Head Bolts, nuts, and 10 5/16" washers.

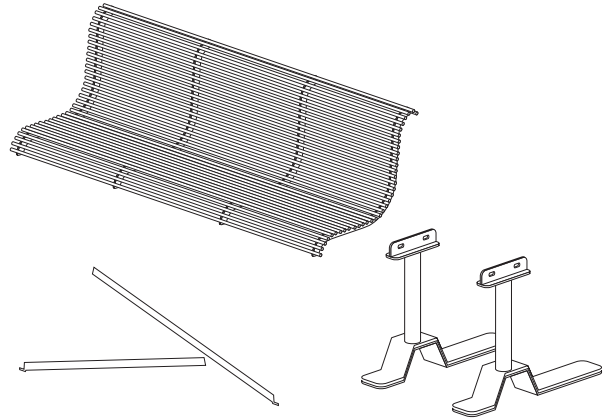

### Step 2:

Assembly of one rod bench. Take the rod seat and flip it over, then take one of the leg (make sure that the leg is on the inside of the bench attachment) and attach it to the rod seat. **With out tightening any of the bolts,** continue onto the other leg and attach the bolts at the top of the leg. Next attach the two center braces to the tabs that come off of the legs and the tab in the center of the seat. Place the bench back up right.

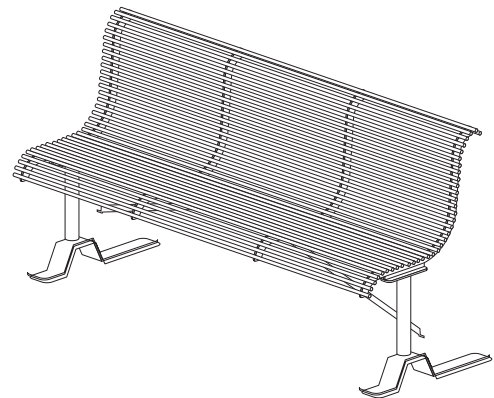

*(To prevent damage to your bench place a blanket underneath the bench.)*

---

### Step 3:

After all bolts are in place, make sure the bench is level before tightening all of the bolts in the same progression that you started with. After all bolts are tightened enjoy your new bench.

