

## SPECS AND INSTALL INSTRUCTIONS

### Single-Post Perforated Picnic Table

SKU:

---

4' CF-5UBGS      6' CF-B7ANT



#### Product maintenance

Inspect all hardware and fasteners, regularly check that all nuts and bolts are secure. Periodically examine for any signs of vandalism on any of your products thermoplastic surfaces. If any thermoplastic surface is vandalized by spray paint, simply take a rag and a aerosol can of WD40 ® and wipe the spray paint off. If the thermoplastic surface has any cuts simply take an industrial heat gun to the affected area. For regular cleaning use soap and water.

#### Thermoplastic Coating

Our outdoor furniture is covered in a copolymer-based thermoplastic powder coating. Thermoplastic is environmentally safe, the coating will never fade, crack, peel, warp, or discolor for the life of the product. Thermoplastic has the best adhesion rate of any other process. This keeps the metal base free of any corrosion possibilities. Thermoplastic is applied at a thickness of 25-30 mills. This allows maximum protection with the best possible surface. Thermoplastic can be easily repaired. Cuts are repaired by heating the affected area with an industrial heat gun. The thermoplastic will rebound itself. The properties of thermoplastic also make spray painting difficult for vandals. Simply wash product with a standard industrial cleaner.

#### Specifications

##### General

All seats and table tops of the listed products above are protected with Thermoplastic coating. Black powder coated galvanized steel legs and support structure. Available in expanded metal and perforated metals. Anti-skateboard tab is also available for all models above.

Check for any damaged or missing parts of if you have problems assembling your furniture / equipment please call our Customer Service Representatives.

# Pedestal Metal Picnic Table

Top view

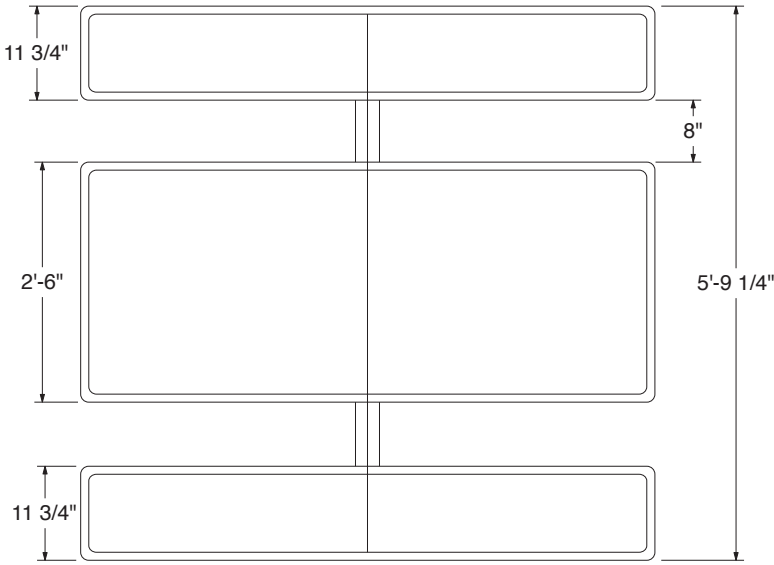

Iso Frame assembled

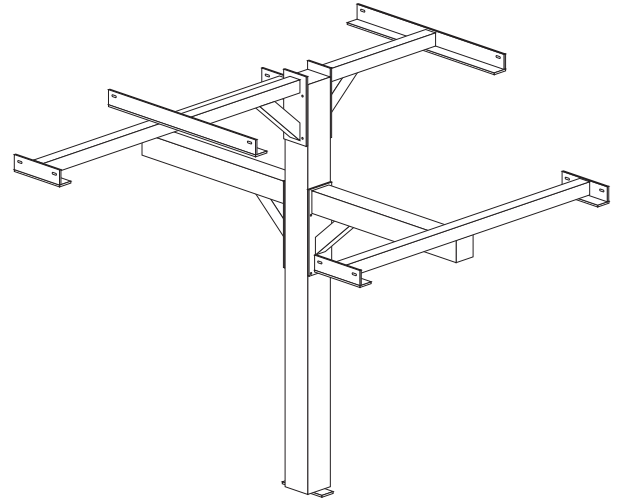

Side view

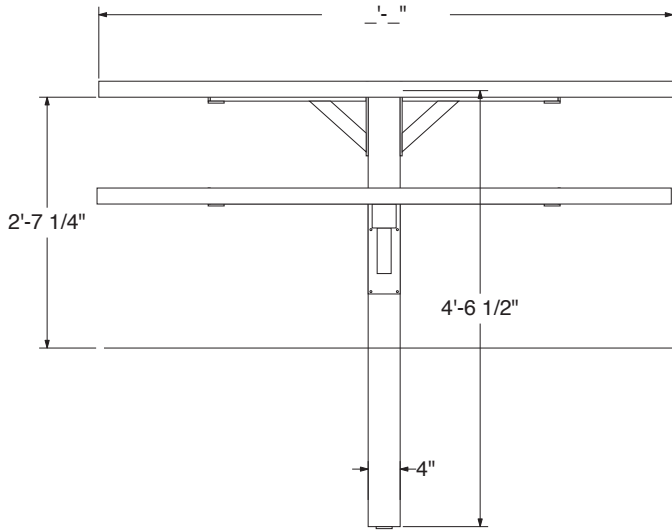

Front View

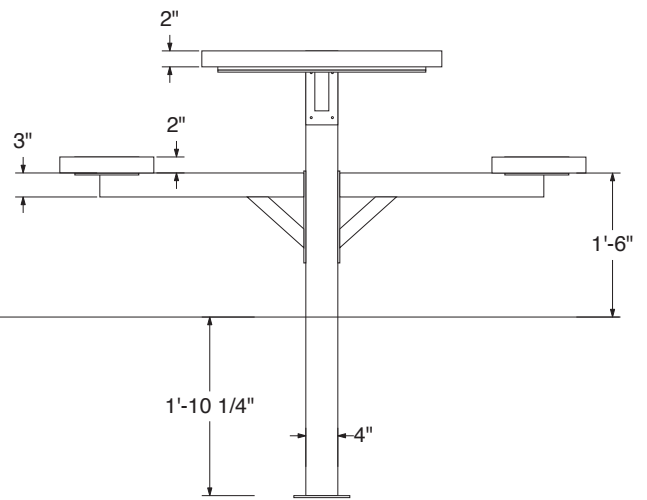

## Available Styles



Expanded Metal



Perforated Metal

## Quantities (per bench)

1A - 5/16" Hex head bolts	- qty 12
1B - 5/16" Washer	- qty 24
1C - 5/16" Nut	- qty 12
2 - Table seats	- qty 2
3 - Table top	- qty 1
4 - Pedestal (per bench)	- qty 1
5 - Seat arms	- qty 2
6 - Table arms	- qty 2
7A - 3/8"x5 Hex head bolt	- qty 8
7B - 3/8"x5 Washer	- qty 8
7C - 3/8"x5 Nut	- qty 8

## Hardware

(A) 5/16" Hex head bolt	
(B) 5/16" Washer	
(C) 5/16" Nut	
(A) 3/8"x5 Hex head bolt	
(B) 3/8"x5 Washer	
(C) 3/8"x5 Nut	

scale 1/2" = 1'



# Assembly Instructions

---

Pedestal expanded metal picnic table  
Pedestal perforated metal picnic table

Note: Work 1 one side at a time.

Do not tightly secure bolts until product is fully assembled.

---

## Step 1:

Check that all hardware, legs, and seats are accounted for. Total parts for the assembly of one pedestal picnic table. Two legs braces, two seats, two table braces, one table top, one pedestal pole, fifteen 5/16" Hex Head Bolts, nuts, and thirty washers.

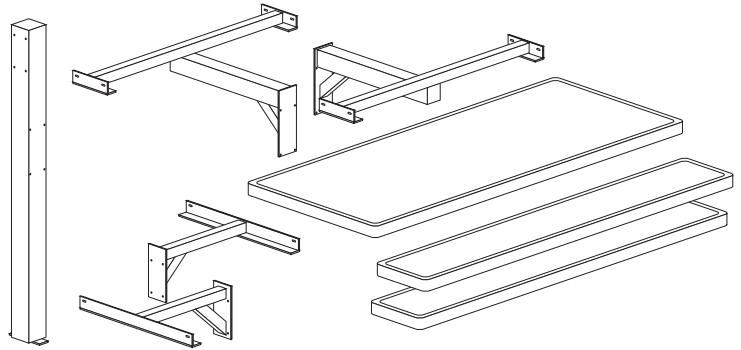

## Step 2:

To assemble a pedestal picnic table, start by making a post hole with the dimensions of 12" X 12" and a minimum depth of 17". Before you place your post into the hole you just made, take the two smaller arms and attach them to the top of the post. Place your table top face down so that you can attach the arms to the table. After you have the table attached tighten all of the bolts that you have in. Take the post with the table top on into the hole, fill it with concert and level it off, this will be the easiest way to make sure the table is in and level. After the concert dries come back and attach the last two arms for you seats.

*(To prevent damage to your bench place a blanket underneath the bench.)*

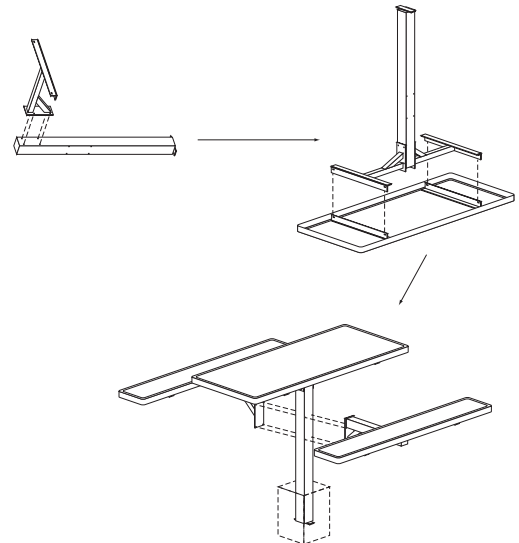

## Step 3:

After the last two arms are in place, make sure the seats are level and then tighten all of the remaining bolts in the same progression that you started with. After all bolts are tightened enjoy your new pedestal picnic table.

