

## SPECS AND INSTALL INSTRUCTIONS

### Perforated Metal Permanent Mount Picnic Table

SKU:

---

4' CF-E806X      6' CF-RS52U  
8' CF-VL7CF      8' CF-0ZIIG  
ADA



#### Product maintenance

Inspect all hardware and fasteners, regularly check that all nuts and bolts are secure. Periodically examine for any signs of vandalism on any of your products thermoplastic surfaces. If any thermoplastic surface is vandalized by spray paint, simply take a rag and an aerosol can of WD40® and wipe the spray paint off. If the thermoplastic surface has any cuts simply take an industrial heat gun to the affected area. For regular cleaning use soap and water.

#### Thermoplastic Coating

Our outdoor furniture is covered in a copolymer-based thermoplastic powder coating. Thermoplastic is environmentally safe, the coating will never fade, crack, peel, warp, or discolor for the life of the product. Thermoplastic has the best adhesion rate of any other process. This keeps the metal base free of any corrosion possibilities. Thermoplastic is applied at a thickness of 25-30 mills. This allows maximum protection with the best possible surface. Thermoplastic can be easily repaired. Cuts are repaired by heating the affected area with an industrial heat gun. The thermoplastic will rebound itself. The properties of thermoplastic also make spray painting difficult for vandals. Simply wash product with a standard industrial cleaner.

#### Specifications

##### General

All seats and table tops of the listed products above are protected with Thermoplastic coating. Black powder coated galvanized steel legs and support structure. Available in expanded metal and perforated metals. Anti-skateboard tab is also available for all models above.

Check for any damaged or missing parts of if you have problems assembling your furniture / equipment please call our Customer Service Representatives.

# Permanent Mount Metal Picnic Table

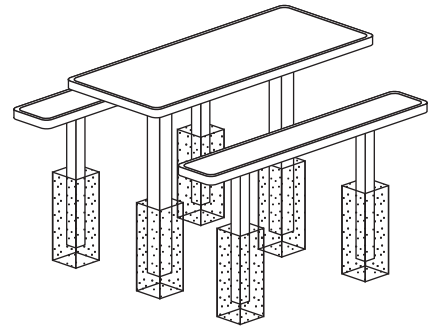

Top view

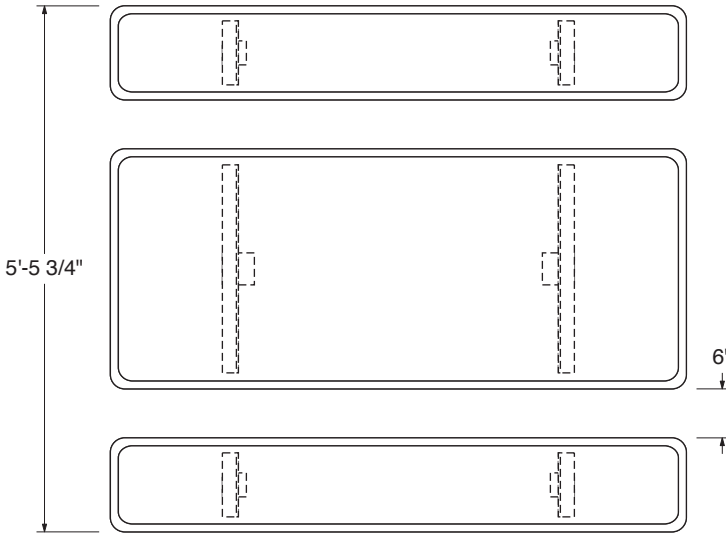

Legs

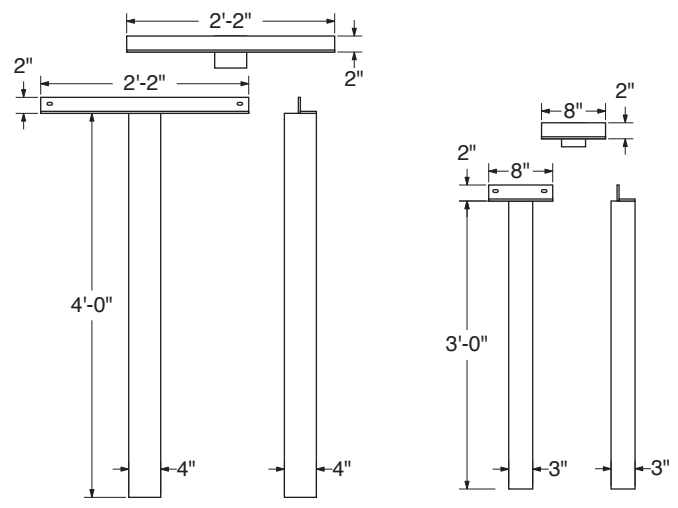

Front View



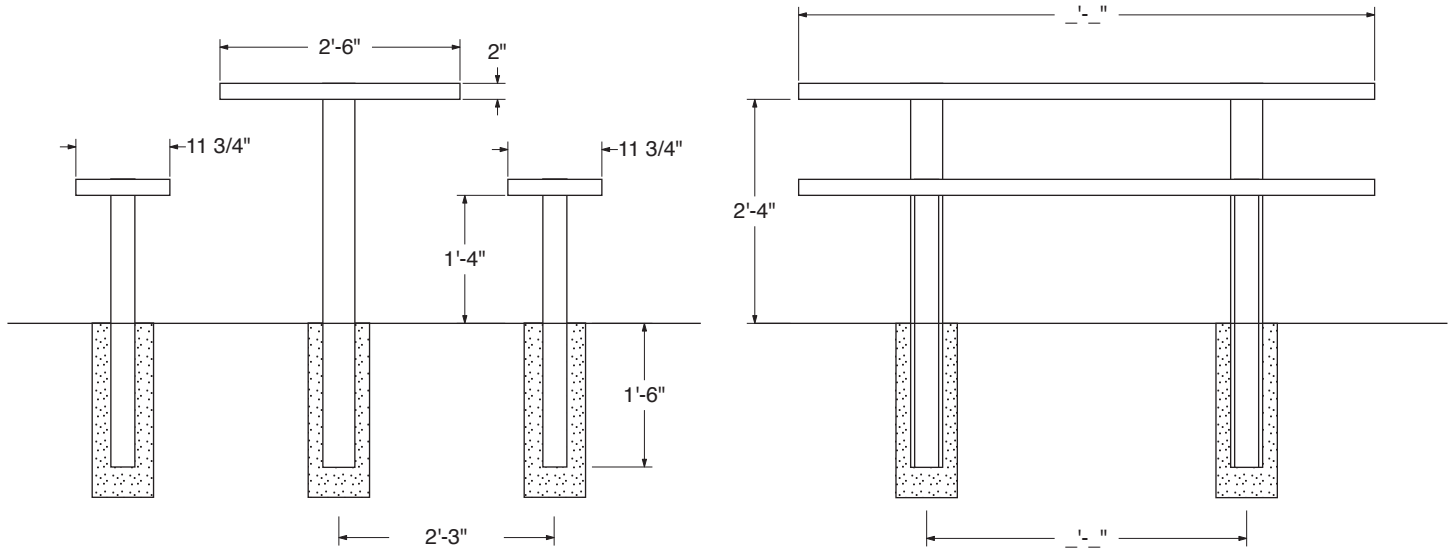

Side view



## Available Styles

## Quantities (per bench)

## Hardware

 Expanded Metal	1A - 5/16" Hex head bolts	- qty 12	(A) 5/16" Hex head bolt 
	1B - 5/16" Washer	- qty 24	
 Perforated Metal	1C - 5/16" Nut	- qty 12	(C) 5/16" Nut 
	2 - Table seats	- qty 2	
	3 - Table top	- qty 1	
	4 - Legs (for seats)	- qty 4	
	5 - Legs (for table top)	- qty 2	

scale 1/2" = 1'



# Assembly Instructions

---

Permanent mount expanded metal picnic table  
Permanent mount perforated metal picnic table

Note: Work 1 one side at a time.

Do not tightly secure bolts until product is fully assembled.

---

## Step 1:

Check that all hardware, legs, and seats are accounted for. Total parts for the assembly of one permanent mount picnic table, four IG legs, two seats, two table IG legs, one table top twelve 5/16" Hex Head Bolts, nuts, and twenty four washers.

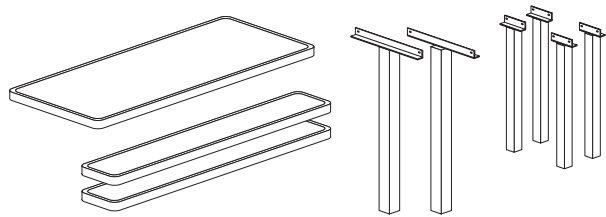

## Step 2:

Assembly of all permanent mount picnic tables are the same. Start with digging you six holes to place your picnic table, make sure the holes are at the specified distance on page 2. Then take the table top and flip it over then take one of the table legs (make sure that the leg is on the outside of the brace attachment) and attach it to the table top. With tightening all of the bolts, continue onto the other leg. Next attach the two seat legs to one of the seats, same as the table top then continue on to the other seat. Place the table top into the two holes assigned for your table, make sure the table is level then fill the hole with concrete. Now take the seats and place them into the correct holes, make sure they are level and fill them with concrete.

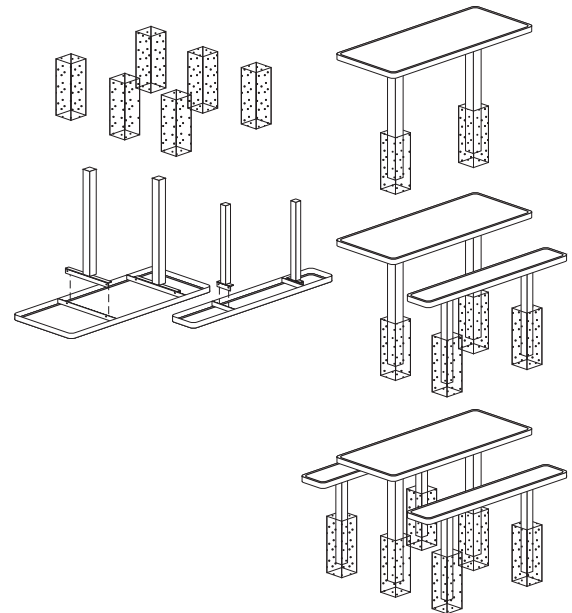

*(To prevent damage to your bench place a blanket underneath the bench.)*

---

## Step 3:

After the concrete dries and all of the bolts are tightened enjoy your permanent mount picnic table.

