

SPECS AND INSTALL INSTRUCTIONS

Round Expanded Metal Picnic Table with Chairs

SKU:

36" CF-23PAX



Product maintenance

Inspect all hardware and fasteners, regularly check that all nuts and bolts are secure. Periodically examine for any signs of vandalism on any of your products thermoplastic surfaces. If any thermoplastic surface is vandalized by spray paint, simple take a rag and a aerosol can of WD40 ® and wipe the spray paint off. If the thermoplastic surface has any cuts simple take an industrial heat gun to the affected area. For regular cleaning use soap and water.

Thermoplastic Coating

Our outdoor furniture is covered in a copolymer-based thermoplastic powder coating. Thermoplastic is environmentally safe, the coating will never fade, crack, peel, warp, or discolor for the life of the product. Thermoplastic has the best adhesion rate of any other process. This keeps the metal base free of any corrosion possibilities. Thermoplastic is applied at a thickness of 25-30 mills. This allows maximum protection with the best possible surface. Thermoplastic can be easily repaired. Cuts are repaired by heating the affected area with an industrial heat gun. The thermoplastic will rebound itself. The properties of thermoplastic also make spray painting difficult for vandals. Simply wash product with a standard industrial cleaner.

Specifications

General

All seats and table tops of the listed products above are protected with Thermoplastic coating. Black powder coated galvanized steel legs and support structure. Available in expanded metal and perforated metals.

Check for any damaged or missing parts of if you have problems assembling your furniture / equipment please call our Customer Service Representatives.

36" Round Expanded Metal Picnic Table with Chairs

Top view

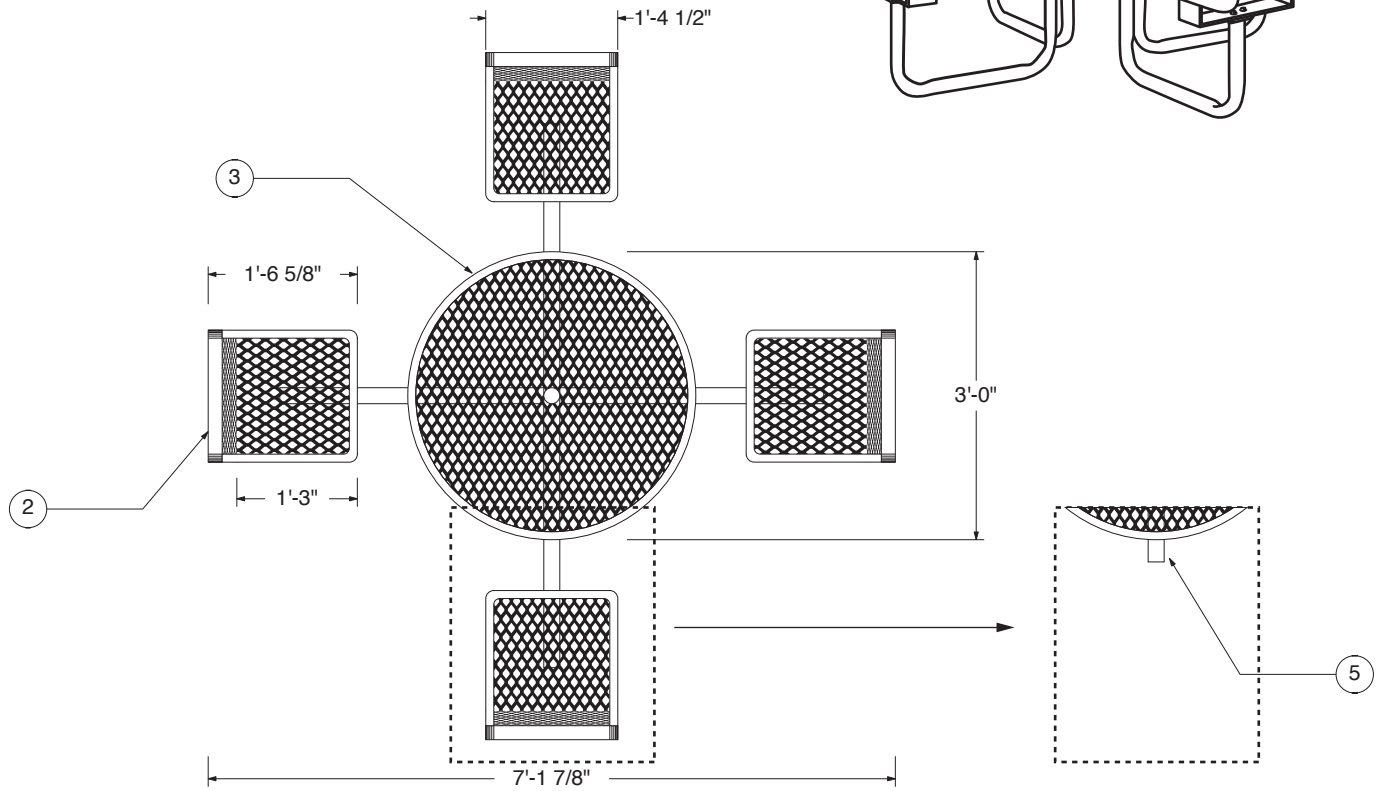
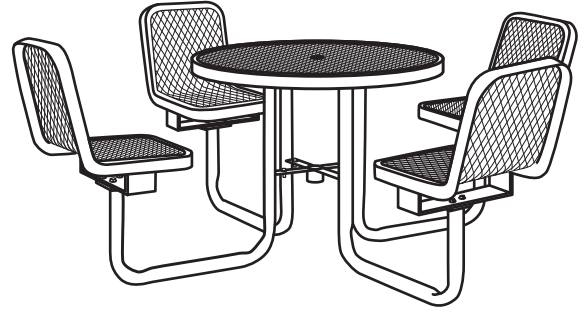



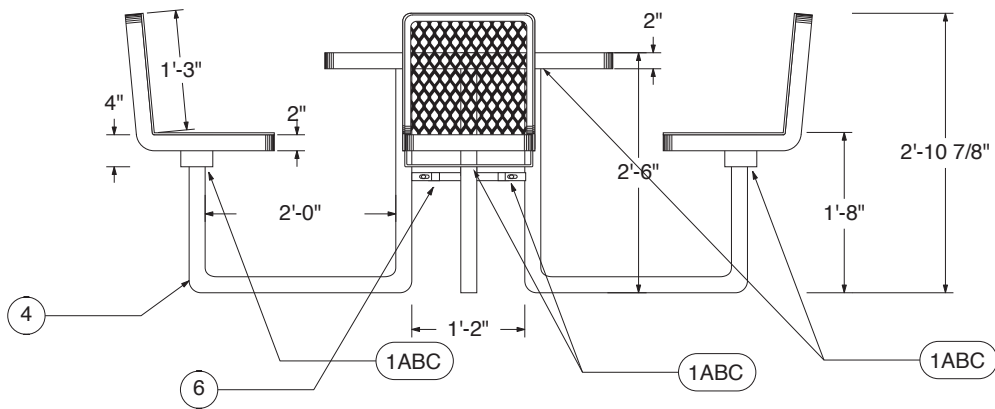

Front View



Available Styles

Quantities (per bench)

Hardware

 Expanded Metal	1A - 5/16" Hex head bolts	- qty 24	(A) 5/16" Hex head bolt  (B) 5/16" Washer  (C) 5/16" Nut 
	1B - 5/16" Washer	- qty 48	
	1C - 5/16" Nut	- qty 24	
	2 - Seats	- qty 4	
	3 - Table top	- qty 1	
	4 - Legs	- qty 4	
5 - Seats (R36WC3-P)	- qty 3		
6 - Cross brace	- qty 1		

scale 1/2" = 1'



Assembly Instructions

36" Round Table w/attached Chairs

Standard Umbrellas

Note: Work 1 one side at a time.

Do not tightly secure bolts until product is fully assembled.

Step 1:

Check that all hardware, legs, and seats are accounted for. Total parts for the assembly of one 36" round table w/ chairs, four legs, four chairs, one center brace, one table top twenty four 5/16" Hex Head Bolts, nuts, and forty eight washers.

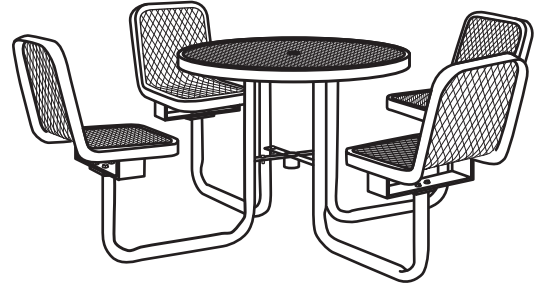

Step 2:

Assembly of the 36" round table w/ chairs and ADA are the same. Take the table top and flip it over then take one of the leg (make sure that the leg is on the outside of the table attachment) and attach it to the table top. With out tightening any of the bolts, continue onto the other leg and attach the bolts at the top of the leg. Next attach the center braces to the legs of the table. Put the table back up right and then attach the four seats, start with one side and move around the table.



(To prevent damage to your bench place a blanket underneath the bench.)

Step 3:

After all bolts are in place, make sure the table is level before tightening all of the bolts in the same progression that you started with. After all bolts are tightened enjoy your new 36" round table w/ chairs.

