

## SPECS AND INSTALL INSTRUCTIONS

### Standard Perforated Metal Picnic Table

SKU:

---

4' CF-7NB31      6' CF-XVVZH

8'<sup>ADA</sup>CF-LNDTW      8' CF-YPK6M

10' CF-IJF81      12' CF-SFS84



### Product maintenance

Inspect all hardware and fasteners, regularly check that all nuts and bolts are secure. Periodically examine for any signs of vandalism on any of your products thermoplastic surfaces. If any thermoplastic surface is vandalized by spray paint, simple take a rag and a aerosol can of WD40 ® and wipe the spray paint off. If the thermoplastic surface has any cuts simple take an industrial heat gun to the affected area. For regular cleaning use soap and water.

### Thermoplastic Coating

Our outdoor furniture is covered in a copolymer-based thermoplastic powder coating. Thermoplastic is environmentally safe, the coating will never fade, crack, peel, warp, or discolor for the life of the product. Thermoplastic has the best adhesion rate of any other process. This keeps the metal base free of any corrosion possibilities. Thermoplastic is applied at a thickness of 25-30 mills. This allows maximum protection with the best possible surface. Thermoplastic can be easily repaired. Cuts are repaired by heating the affected area with an industrial heat gun. The thermoplastic will rebound itself. The properties of thermoplastic also make spray painting difficult for vandals. Simply wash product with a standard industrial cleaner.

### Specifications

#### General

All seats and table tops of the listed products above are protected with Thermoplastic coating. Black powder coated galvanized steel legs and support structure. Available in expanded metal and perforated metals. Anti-skateboard tab is also available for all models above.

Check for any damaged or missing parts of if you have problems assembling your furniture / equipment please call our Customer Service Representatives.

# Standard Picnic Table

Top view

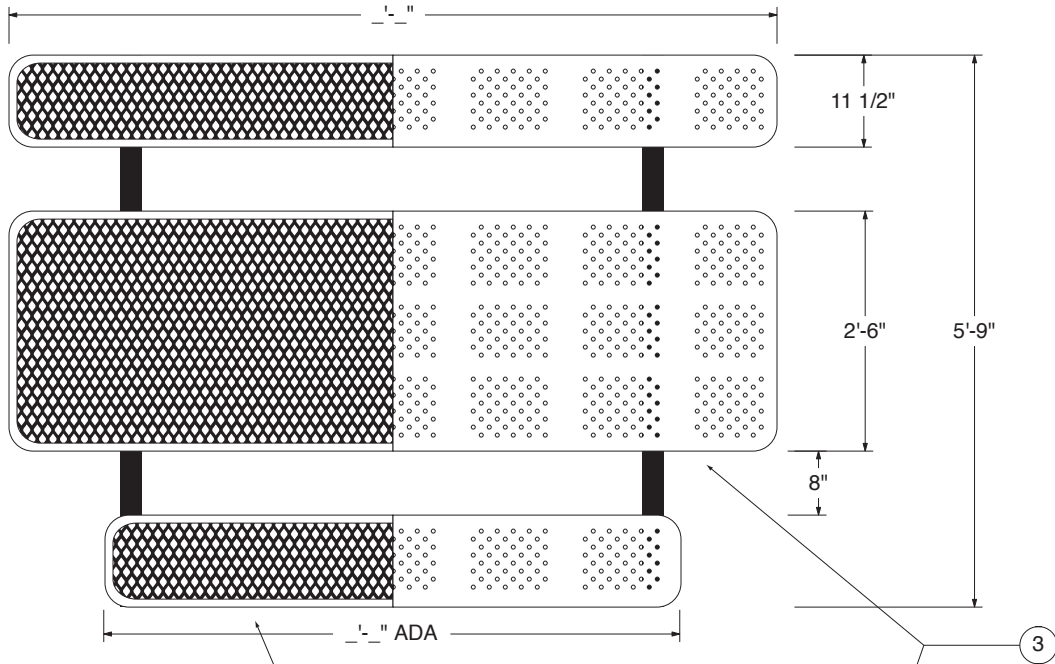

Front View

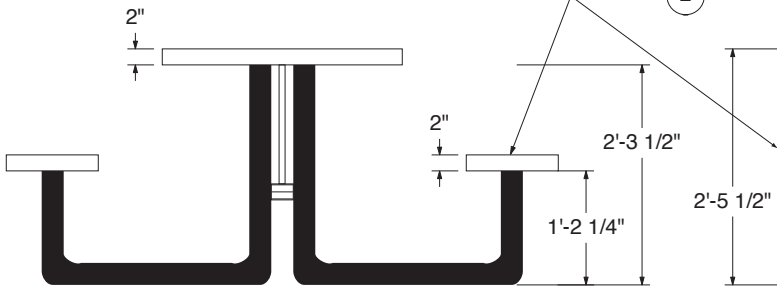

Side view

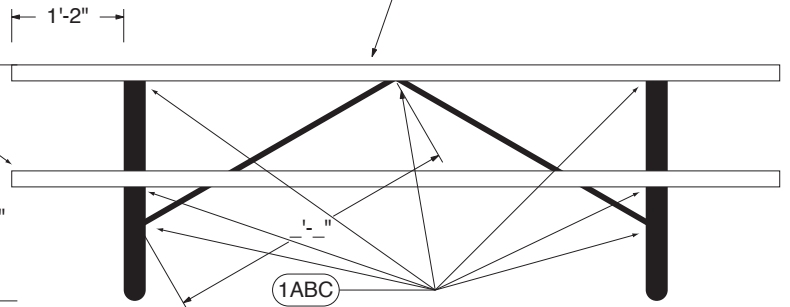

12' bench is made up of two 6' benches  
scale 1/4" = 1'

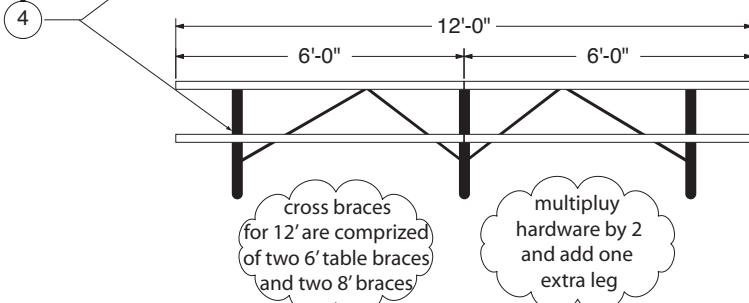

Center Leg

Front view



Side view

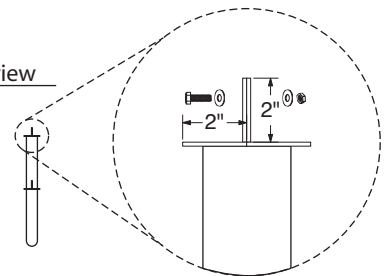

## Available Styles



Expanded Metal



Perforated Metal

## Quantities (per bench)

1A - 5/16" Hex head bolts	- qty 15
1B - 5/16" Washer	- qty 30
1C - 5/16" Nut	- qty 15
2 - Table seats	- qty 2
3 - Table top	- qty 1
4 - Leg Types (per bench)	- qty 2
5 - Cross braces	- qty 2

## Hardware

(A) 5/16" Hex head bolt



(B) 5/16" Washer



(C) 5/16" Nut



scale 1/2" = 1'



# Assembly Instructions

---

## Standard Expanded Metal Picnic Table

## Standard Perforated Metal Picnic Table

Note: Work 1 one side at a time.

Do not tightly secure bolts until product is fully assembled.

---

### Step 1:

Check that all hardware, legs, and seats are accounted for. Total parts for the assembly of one standard picnic table. Two legs (SM or IG or P), two seats, two brace rod, fifteen 5/16" Hex Head Bolts and nuts, and thirty 5/16" washers.

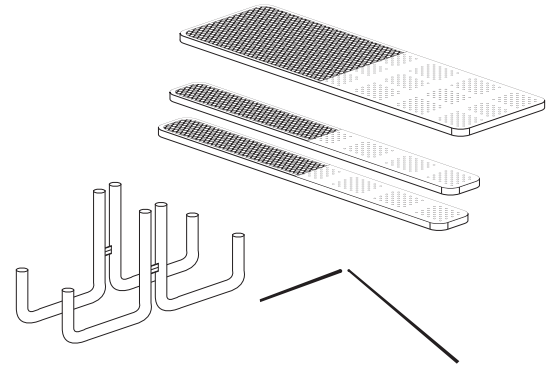

### Step 2:

Assembly of all standard picnic tables are the same. Take the table top and flip it over then take one of the leg (make sure that the leg is on the outside of the bench attachment) and attach it to the table top. With out tightening any of the bolts, continue onto the other leg and attach the bolts at the top of the leg (if you are working on a 12' table then the second leg will go on the outside of the table. This will allow you to attach the two 6' benches together). Next attach the two center braces to the under structure of the table. Put the bench back up right and then attach the two seats, start with one side. Now take the second seat and attach it to the legs.

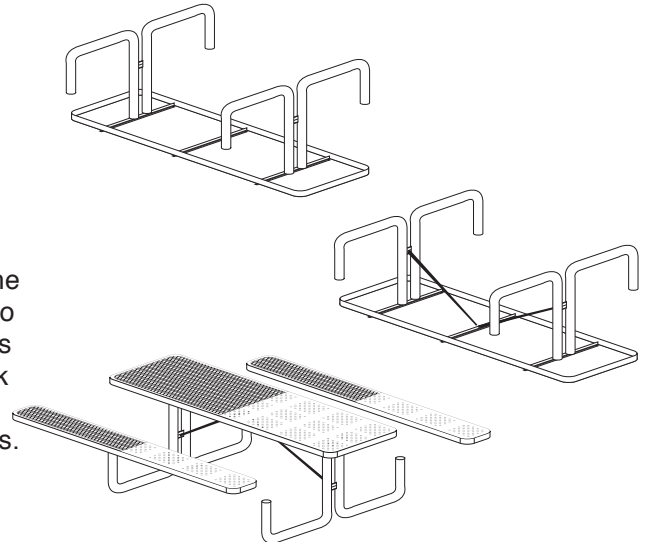

*(To prevent damage to your bench  
place a blanket underneath the bench.)*

---

### Step 3:

After all bolts are in place, make sure the bench is level before tightening all of the bolts in the same progression that you started with. After all bolts are tightened enjoy your new bench.

