



WORKROOM CATALOG

Beautiful Custom Design

Business Contacts

3180 Wetumpka Highway
Montgomery, Alabama 36110-2734
800.510.8325
334.558.0863
Fax: 334.532.0912
www.DesignerCustomSource.com
info@DesignerCustomSource.com
[Facebook.com/DesignerCustomSource](https://www.facebook.com/DesignerCustomSource)
[Twitter.com/DCSource](https://twitter.com/DCSource)
[Pinterest.com/DCSource](https://www.pinterest.com/DCSource)
[LinkedIn.com/company/Designer-Custom-Source](https://www.linkedin.com/company/Designer-Custom-Source)
Blog: www.DesignerCustomSource.net
Hours: Monday – Friday, 8:30 a.m. – 7 p.m. EST

Contributing Editors

Alicia Andrews
Kerry Lang
Miriam Leuthold
Melinda Merijanian
Jennifer Wiggins
Anita Winter
Robert Winter

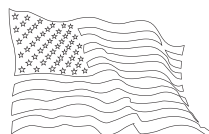

All of our custom products are proudly made in America.

Many thanks to the staff of Designer Custom Source for their hard work and guidance while producing the 2012 Workroom Catalog. Without their contributions and direction, this book would not be possible.

We hope you find the DCS Workroom Catalog a useful tool, and we look forward to working with you on your projects and any special requests you may have. We enjoy adding new products to our site to ensure a one-stop shopping experience for you, so please visit us at www.DesignerCustomSource.com for the most comprehensive list of products, and complimentary accoutrements. Please note that prices and product specifications are subject to change.

All rights reserved. No part of this book may be copied, reproduced or transmitted in any form by any means, electronic or mechanical, including photocopying, recording, or by any information storage or retrieval system, without consent from Designer Custom Source, and OCG, LLC. of Montgomery, Alabama.



TABLE OF CONTENTS

Introduction

Invitation
Meet and Greet / Member Benefits

Cushions

C - 1 Cushion Introduction
C - 3 Bench
C - 9 Chair & Seat
C - 15 Window Seat
C - 19 Chaise & Double Chaise
C - 25 Steamer
C - 29 Ottoman
C - 33 Deep Seating
C - 37 Wicker, Rattan & Settee
C - A Cushion General Specifications
C - C Fabric Yardage
CP - 1 Pricing

Draperies

D - 1 Drapery Introduction
D - 3 Pinch Pleat
D - 5 Goblet Pleat
D - 7 Grommet
D - 9 Rod Pocket
D - 11 Flat Top
D - 13 Tab Top
D - 15 Tie Top
D - A Drapery General Specifications
DP - 1 Pricing

Throw Pillows

TP - 1 Throw Pillow Introduction
TP - 3 Throw Pillow
TP - 3 Throw with Center Button
TP - 4 Lumbar
TP - 4 Duvet
TP - 5 Rectangular Flange
TP - 5 Square Flange
TP - 6 Round with Button
TP - 6 Sunburst
TP - 7 Bolster
TP - 7 Bolster with Shirred End and Button
TP - 8 Bolster with Center Panel
TP - A Throw Pillow Standards
TP - B Pricing and Yardage

Umbrella

U - 1 Umbrella Introduction
U - 3 Market
U - 9 Patio
U - 13 Beach
U - 15 Designer Collections
U - 17 Umbrella Accessories
U - A Umbrella Standards

Customer's Own Material (COM)

COM
COM Procedures
COM FAQ's

Fabric Library

RA - 1 Robert Allen®
S - 1 Sunbrella®
O - 1 Outdura®
G - 1 Geobella™
P - 1 Premier Prints
SA - 1 Sunbrella® Awning-Grade Fabric
OA - 1 Outdura® Awning-Grade Fabric

Designer Resources

Quote Forms
General FAQ's
Fabric Care
Returns & Shipping Policies



CUSHIONS



Multiple styles to select from, plus the addition of your custom template, make our cushion division offering significant. We have had thousands of satisfied clients, and we want you to sit back and relax with confidence, knowing that you will be providing an excellent custom product to your client.



BENCH CUSHIONS

DESIGNER CUSTOM SOURCE offers premium outdoor living cushions and an assortment of fabrics, including Sunbrella®, Robert Allen®, Geobella™, and Outdura®. We select our fabrics based on their reputation in the marketplace, durability, ease of care and warranties. Of course, as with all fabrics, proper care will extend the life of the product.

We believe that what is on the inside is as important as what is on the outside. For outdoor cushions, we recommend our Standard Outdoor fill: CumuPlush, which is a special blend of polyester fibers designed to withstand the elements and retain its shape and resiliency longer than standard densified polyfiber. It's a unique material because it will not retain water, which helps prevent the growth of mold or mildew. For indoor cushions, we provide the following choices: Standard Outdoor (CumuPlush), Standard Indoor (Bio Comfort®, which is a firmer and denser fill), and Premium Indoor (Bio Comfort® foam with polyfiber batting on top and bottom for a plush look and feel). We offer a measurement guide for the following cushion styles: bench, chair, seat, window seat, chaise lounge, ottoman, deep seating, as well as overstuffed cushions for wicker, rattan, and settees.

We pride ourselves in creating beautiful custom cushions using the templates you provide. **Because our cushions are made in half-inch width and depth increments, please round to the nearest half-inch. Measuring, at this point, is critical. To ensure a proper fit, please follow the Cushion Measuring Guides found in the back of this section.**

At Designer Custom Source, we can custom-make any type of chair cushion. **If you have a unique chair that will require something other than our standard sizes, please refer to the Cushion Measuring Guides found in the back of this section.**

A. Style Options

SHAPE OPTIONS

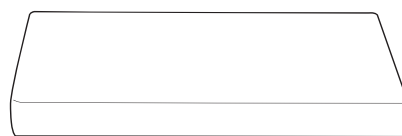

RECTANGLE

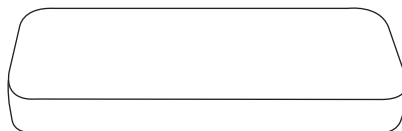

STANDARD ROUNDED CORNERS

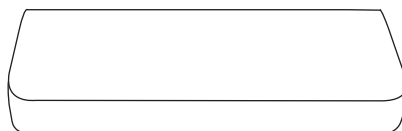

STANDARD ROUNDED FRONT CORNERS

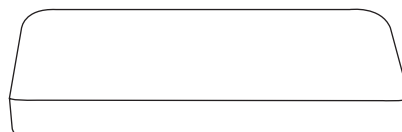

STANDARD ROUNDED BACK CORNERS

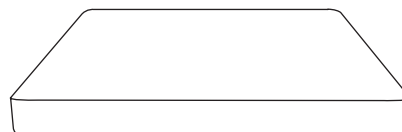

TRAPEZOID



CUSTOM SHAPE

CORNER OPTIONS

Square Corners

- Fabric is cut at a 90° angle with ½” seam allowance.

Rounded Corners

- All standard radii are 4”.
- Trapezoids use a 1”-1 ½” radius on the smallest angles and standard 4” radii for the opposite angles.

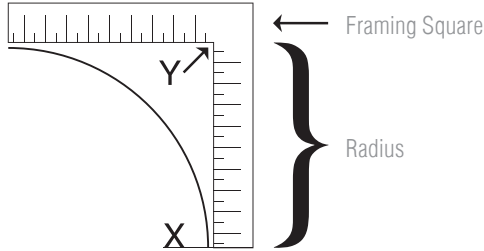

- What this means is that if you take a framing square and place it so that it is along the edges of your corners (see image above) and measure from where the curve starts to the corner of the square, that measurement will be the radius of your cushion’s corners. Most furniture with rounded corners will conform to these specifications. If you require a different radius, please order a custom shaped cushion.
- **Note:** Due to the sewing style required, rounded cushions can only have boxed edges.

B. Edging Options



BOX EDGE

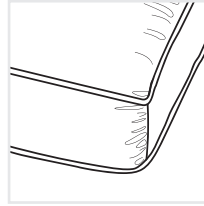

DOUBLE CORD BOX EDGE

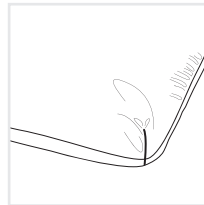

KNIFE EDGE

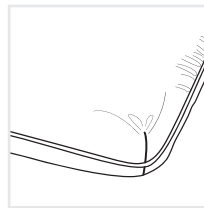

SINGLE CORD KNIFE EDGE

C. Fill Options

FILL OPTIONS



STANDARD OUTDOOR

Flat style fill designed specifically for outdoor use. Our CumuPlush brand is made with a special blend of poly fiber that is bonded together for comfort and resiliency.



PREMIUM INDOOR

Bio Comfort® foam with 1” batting on the top and bottom. This will result in an additional 1”-2” of thickness due to the loft created by the batting.



STANDARD INDOOR

Flat style Bio Comfort® foam designed to remain firm and resilient. Indoor use only.

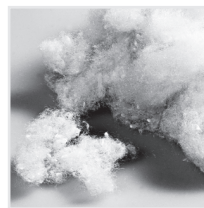

DIRECT FILL

Filled with loose poly fiber.

TUFTED OPTION

General Information

- Only available for Premium Indoor (2"-8" thick) and Direct Fill (3" and 5" thick) fill options.
- We offer one button size option — 1" (25mm) — with an indention target of 1"-2".

Placement and Symmetry General Guidelines

- For Premium Indoor filled cushions, there is a minimum of 4 buttons per cushion regardless of size.
- **Standardized Button Placement:** Equal distance between buttons, as well as their placement relative to the cushion's edge.
 - Number of rows is determined by taking the depth and dividing it by 8", rounding down to the nearest whole number.
 - Number of buttons is determined by taking the width and dividing by 8", rounding down to the nearest whole number.
 - For trapezoidal cushions, the number of buttons is determined by adding the short and long widths; dividing their sum by 2; and then dividing that total by 8", rounding down to the nearest whole number. This is the number of buttons in the short row. Add 1 button for the long row, and for each additional row, add 1 button.
- **Customized Button Placement:** Please submit a template showing each button's placement.

D. Tie Options

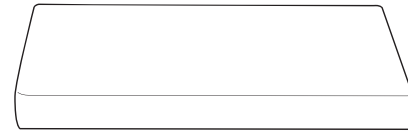

NO TIES

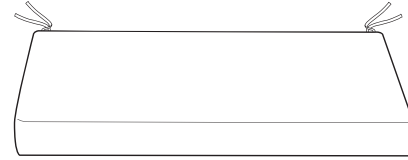

TIES ON THE BACK CORNERS

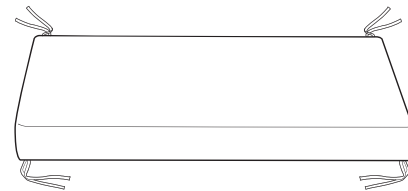

TIES ON FOUR CORNERS

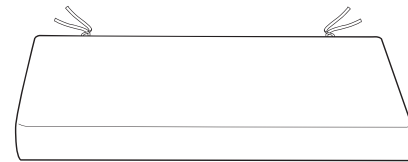

TIES ON THE BACK (INSET 4")

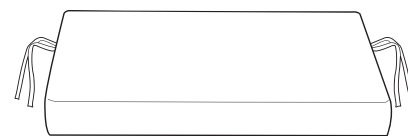

TIES ON THE LEFT AND RIGHT SIDES

Tie Options for Trapezoid Cushions

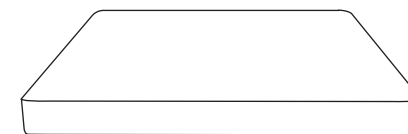

NO TIES

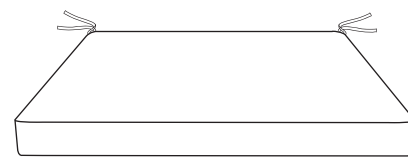

TIES ON THE BACK CORNERS

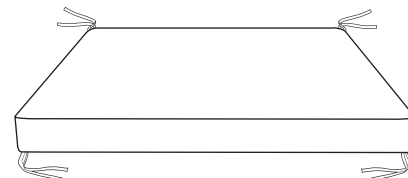

TIES ON FOUR CORNERS

E. Zipper Options

All Standard and Premium filled cushions come with “hidden” zippers. Direct Fill cushions are sewn shut.

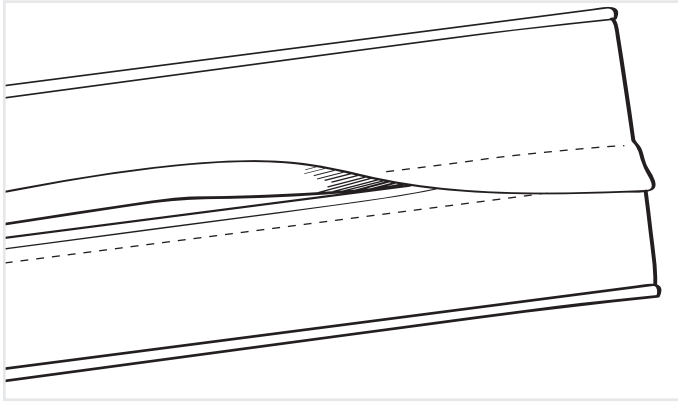

Zippers are made of nylon and come in one of three colors: beige, white, or black.

F. Thickness Options

All cushions have the option of being 2”-8” in thickness, with the exception of knife edge, which allows only 2”-3” thickness.

G. Other Notes

KNIFE EDGE RESTRICTIONS

Knife edge and single cord knife edges are only available on cushions that are 2” or 3” in thickness. Any cushions 4” or greater in thickness must have boxed edges.

DIRECT FILL CUSHIONS

All cushions with Direct Fill must be tufted.

EXTRA-LONG CUSHIONS

All cushions that exceed 106” in length will be folded at half the length to allow for easier shipment. Cushions that are folded will take time to settle out. If you would prefer your cushion shipped flat, we recommend calling our office at 800.510.8325 and requesting your cushion not to be folded. Please note this will incur higher shipping fees. You may also want to consider ordering two separate cushions for your furniture if your project exceeds 106” in length. This can be accomplished by dividing your total length by two. **Note: All cushions 5” in thickness or greater cannot be folded and will require additional shipping fees.**

CUSTOM SHAPE CUSHIONS

If you have a unique cushion that will require something other than our standard shapes, please refer to the Cushion Measuring Guides found in the back of this section.

MAXIMUM CUSHION DIMENSIONS

Cushions can be made up to 120” wide and 80” deep.

DIRECTIONAL FABRICS

We run all directional fabrics vertical (front to back) on a product unless otherwise stated. Please note that vertical run fabrics may cause seams on cushions longer than 50”.

H. Order Dimensions & Summary of Steps

Below is a review of the entire bench cushion order process.

A. STYLE OPTIONS

- Shape Options
 - » Rectangle
 - » Standard Rounded Corners
 - » Standard Rounded Front Corners
 - » Standard Rounded Back Corners
 - » Trapezoid
 - » Custom Shape
- Corner Options
 - » Squared Corner
 - » Rounded Corner

B. EDGING OPTIONS

- Box Edge
- Double Cord Box Edge
- Knife Edge
- Single Cord Knife Edge

C. FILL OPTIONS

- Fill Options
 - » Standard Outdoor
 - » Standard Indoor
 - » Premium Indoor
 - » Direct Fill
- Tufted Option
 - » Thickness
 - » Standard button or COM button
 - » Standardized Button Placement or Customized Button Placement

D. TIE OPTIONS

- Standard Tie Options
 - » No Ties
 - » Ties on the back corners
 - » Ties on four corners
 - » Ties on back (inset 4")
 - » Ties on the left and right sides
- Trapezoid Tie Options
 - » No Ties
 - » Ties on the back corners
 - » Ties on four corners

E. ZIPPER OPTIONS

- Beige
- White
- Black

F. THICKNESS OPTIONS

- Box Edge: 2"-8"
- Knife Edge: 2"-3"

G. DIMENSIONS

- Width
- Depth
- Thickness

H. CHOOSE FABRIC OPTION

- Reference the Fabric Library in the back or our Online Fabric Tool, or provide COM Fabric



CHAIR & SEAT CUSHIONS



A. Style Options

SHAPE OPTIONS – BACK & SEAT CONNECTED

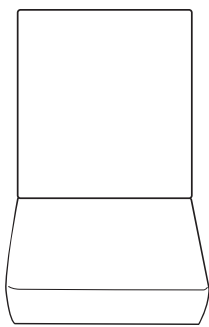

RECTANGLE

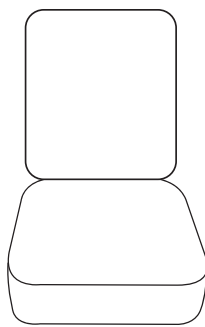

STANDARD ROUNDED CORNERS

SHAPE OPTIONS – BACK OR SEAT

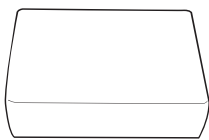

RECTANGLE

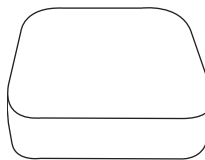

STANDARD ROUNDED CORNERS



STANDARD ROUNDED BACK CORNERS

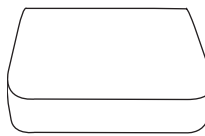

STANDARD ROUNDED FRONT CORNERS

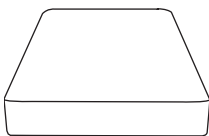

TRAPEZOID

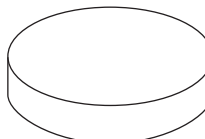

ROUND

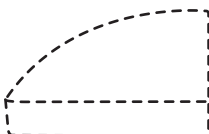

CUSTOM SHAPE

CORNER OPTIONS

Square Corners

- Fabric is cut at a 90° angle with ½” seam allowance.

Rounded Corners

- All standard radii are 4”.
- Trapezoids use a 1”-1 ½” radius on the smallest angles and standard 4” radii for the opposite angles.

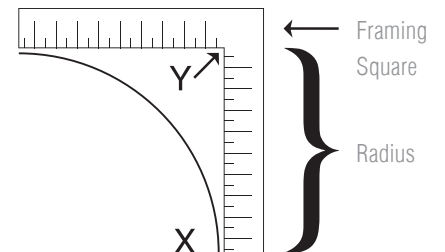

- What this means is that if you take a framing square and place it so that it is along the edges of your corners (see image above) and measure from where the curve starts to the corner of the square, that measurement will be the radius of your cushion’s corners. Most furniture with rounded corners will conform to these specifications. If you require a different radius, please order a custom shaped cushion.
- Note:** Due to the sewing style required, rounded cushions can only have boxed edges.

B. Edging Options

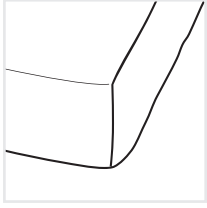

BOX EDGE



KNIFE EDGE

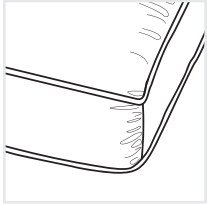

DOUBLE CORD BOX EDGE

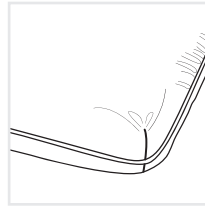

SINGLE CORD KNIFE EDGE

C. Fill Options

FILL OPTIONS – BACK AND SEAT

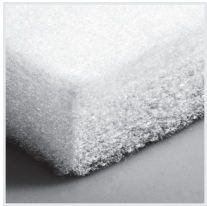

STANDARD OUTDOOR

Flat style fill designed specifically for outdoor use. Our CumuPlush brand is made with a special blend of poly fiber that is bonded together for comfort and resiliency.



STANDARD INDOOR

Flat style Bio Comfort® foam designed to remain firm and resilient. Indoor use only.

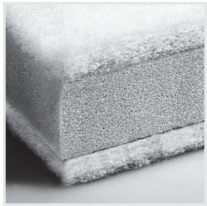

PREMIUM INDOOR

Bio Comfort® foam with 1” batting on the top and bottom. This will result in an additional 1”-2” of thickness due to the loft created by the batting.

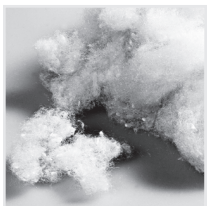

DIRECT FILL

Filled with loose poly fiber.

FILL OPTIONS – BACK ONLY

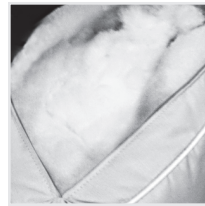

PLUSH

Plush style fill consists of two sheets of batting sandwiching a loose poly fiber fill. The batting gives the necessary rigidity for holding the cushion’s shape, while the loose poly fiber offers a luxurious, “plush” appeal.

TUFTED OPTION

General Information

- Only available for Premium Indoor (2”-8” thick) and Direct Fill (3” and 5” thick) fill options.
- We offer one button size option — 1” (25mm) — with an indentation target of 1”-2”.

Placement and Symmetry General Guidelines

- **Number of Buttons:** For Premium Indoor filled cushions, there is a minimum of 4 buttons per cushion regardless of size. “Plush” back cushion button options: no buttons, 1 button, 4 buttons, or 5 buttons.
- **Standardized Button Placement:** Equal distance between buttons, as well as their placement relative to the cushion’s edge.
 - Number of rows is determined by taking the depth and dividing it by 8”, rounding down to the nearest whole number.
 - Number of buttons is determined by taking the width and dividing by 8”, rounding down to the nearest whole number.

C. Tufted Option continued

- For trapezoidal cushions, the number of buttons is determined by adding the short and long widths; dividing their sum by 2; and then dividing that total by 8", rounding down to the nearest whole number. This is the number of buttons in the short row. Add 1 button for the long row, and for each additional row, add 1 button.
- Back cushion button placements:
 - » 1 Button: centered.
 - » 4 Buttons: equidistant and centered in a box or diamond pattern.
 - » 5 Buttons: 4 buttons equidistant and centered in a box or diamond pattern, with the last button centered inside the 4-button pattern.
- **Customized Button Placement:** Please submit a template showing each button's placement.

D. Tie Options

BACK & SEAT – CONNECTED



NO TIES

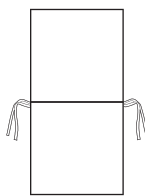

TWO TIES
Placed on the first break.

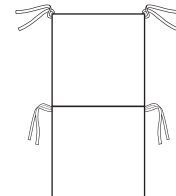

FOUR TIES
Placed on the top of the cushion and on the first break.

BACK & SEAT – NOT CONNECTED



NO TIES

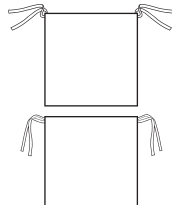

FOUR TIES
Placed on the top of the cushion and on the back of the seat cushion.

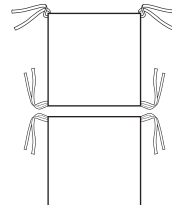

SIX TIES
Placed on the four corners of the back cushion and two ties on the seat at the back.

BACK OR SEAT

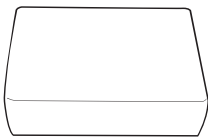

NO TIES

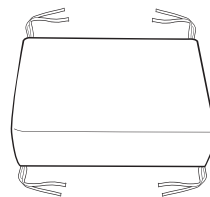

TIES ON FOUR CORNERS

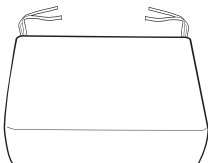

TIES ON THE BACK CORNERS

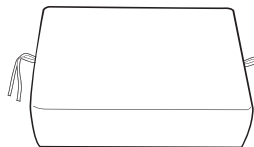

TIES ON THE LEFT AND RIGHT SIDES

Tie Options for Trapezoid Cushions

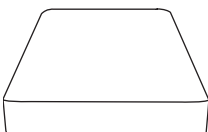

NO TIES

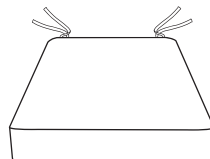

TIES ON THE BACK CORNERS

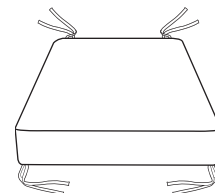

TIES ON FOUR CORNERS

Tie Options for Round Cushions

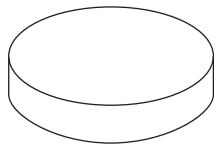

NO TIES

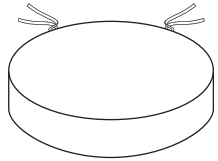

TIES ON THE BACK

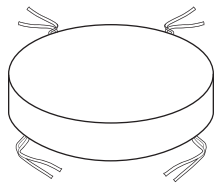

TIES ON THE FRONT AND BACK

E. Connection Options

JOINING PIECE

- Required on all cushions 5” thick or greater
- Finished joining piece should be 2” wide on all cushions 4” or greater in thickness; 1” wide on cushions 2” or 3” thick.

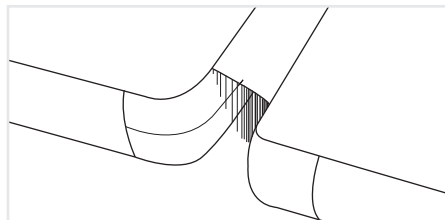

JOINING PIECE

PINCHED

- Only available on cushions 4” or less in thickness.
- Use the same amount of fabric for the ease (or “take up”) as the thickness of the cushion.
 - For example: A 3” cushion will use 3” of fabric for the *ease* — the gap of fabric between the cushions that are to be joined.

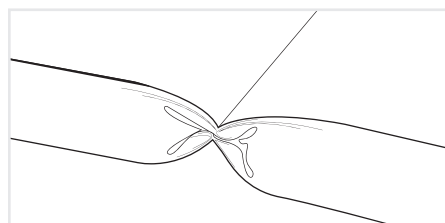

PINCHED

F. Zipper Options

All Standard and Premium filled cushions come with “hidden” zippers. Direct Fill cushions are sewn shut.

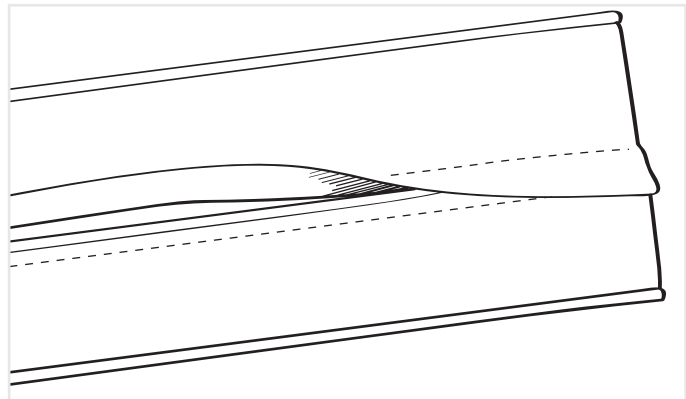

Zippers are made of nylon and come in one of three colors: beige, white, or black.

G. Thickness Options

All cushions have the option of being 2”-8” in thickness, with the exception of knife edge, which allows only 2”-3” thickness.

H. Other Notes

KNIFE EDGE RESTRICTIONS

Knife edge and single cord knife edges are only available on cushions that are 2” or 3” in thickness. Any cushions 4” or greater in thickness must have boxed edges.

DIRECT FILL CUSHIONS

All cushions with Direct Fill must be tufted.

CUSTOM SHAPE CUSHIONS

If you have a unique cushion that will require something other than our standard shapes, please refer to the Cushion Measuring Guide pages found in the back of this section.

MAXIMUM CUSHION DIMENSIONS

Cushions can be made up to 120" wide and 80" deep.

DIRECTIONAL FABRICS

We run all directional fabrics vertical (front to back) on a product unless otherwise stated. Please note that vertical run fabrics may cause seams on cushions longer than 50".

I. Order Dimensions & Summary of Steps

Below is a review of the entire chair and seat cushion order process.

A. STYLE OPTIONS

- Shape Options – Back & Seat Cushions Connected
 - » Rectangle
 - » Standard Rounded Corners
- Shape Options – Back OR Seat Cushions
 - » Rectangle
 - » Standard Rounded Corners
 - » Standard Rounded Front Corners
 - » Standard Rounded Back Corners
 - » Trapezoid
 - » Round
 - » Custom Shape
- Corner Options
 - » Squared Corner
 - » Rounded Corner

B. EDGING OPTIONS

- Box Edge
- Double Cord Box Edge
- Knife Edge
- Single Cord Knife Edge

C. FILL OPTIONS

- Fill Options – Back & Seat
 - » Standard Outdoor
 - » Standard Indoor
 - » Premium Indoor
 - » Direct Fill
- Fill Options – Back Only
 - » Plush
- Tufted Option
 - » Thickness
 - » Standard Button or COM Button
 - » Standardized Button Placement or Customized Button Placement

D. TIE OPTIONS

- Back & Seat Cushions – Connected
 - » No ties
 - » Two Ties: Placed on the first break
 - » Four Ties: Placed on the top of the cushion and on the first break
- Back & Seat Cushions – Not Connected
 - » No ties
 - » Four Ties: Placed on the top of the cushion and on the back of the seat cushion
 - » Six Ties: Placed on the four corners of the back cushion and two ties on the seat at the back
- Back OR Seat Cushions
 - » No ties
 - » Ties on the back corners
 - » Ties on all corners
 - » Ties on the left and right sides
- Back OR Seat Cushions – Trapezoid
 - » No ties
 - » Ties on the back corners
 - » Ties on all corners
- Back OR Seat Cushions – Round
 - » No ties
 - » Ties on the back side
 - » Ties on the front and back

E. ZIPPER OPTIONS

- Beige
- White
- Black

F. THICKNESS OPTIONS

- Box Edge: 2"-8"
- Knife Edge: 2"-3"

G. DIMENSIONS

- Rectangular Shape Options
 - » Width
 - » Depth
 - » Thickness
- Trapezoidal Shape Options
 - » Short Width
 - » Long Width
 - » Depth
 - » Thickness
- Round Shape Options
 - » Diameter
 - » Thickness

H. FABRIC OPTIONS

- Reference the Fabric Library in the back or our Online Fabric Tool, or provide COM Fabric



WINDOW SEAT CUSHIONS

A. Style Options

SHAPE OPTIONS

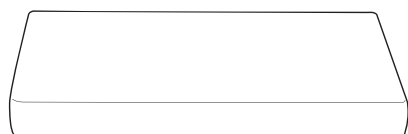

RECTANGLE

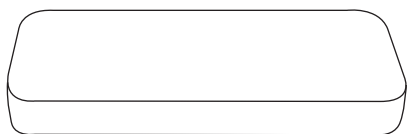

STANDARD
ROUNDED
FRONT
CORNERS

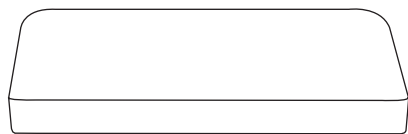

STANDARD
ROUNDED
BACK
CORNERS

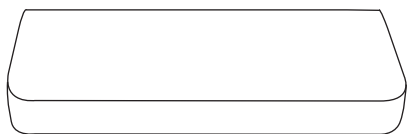

STANDARD
ROUNDED
FRONT
CORNERS

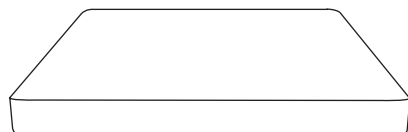

TRAPEZOID



CUSTOM
SHAPE

CORNER OPTIONS

Square Corners

- Fabric is cut at a 90° angle with 1/2" seam allowance.

Rounded Corners

- All standard radii are 4".
- Trapezoids use a 1"-1 1/2" radius on the smallest angles and standard 4" radii for the opposite angles.

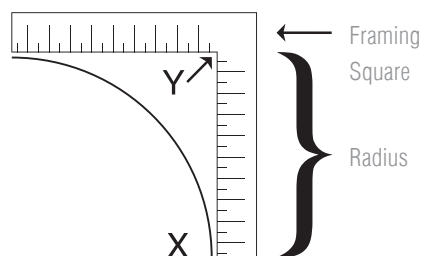

- What this means is that if you take a framing square and place it so that it is along the edges of your corners (see image above) and measure from where the curve starts to the corner of the square, that measurement will be the radius of your cushion's corners. Most furniture with rounded corners will conform to these specifications. If you require a different radius, please order a custom shaped cushion.
- **Note:** Due to the sewing style required, rounded cushions can only have boxed edges.

B. Edging Options

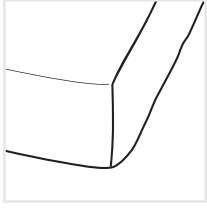

BOX EDGE

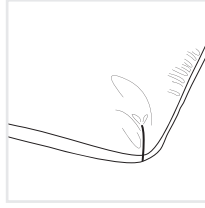

KNIFE EDGE

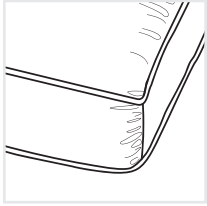

DOUBLE CORD BOX EDGE

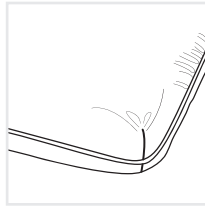

SINGLE CORD KNIFE EDGE

C. Fill Options

FILL OPTIONS

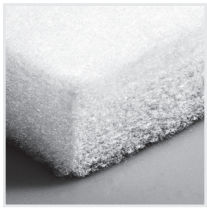

STANDARD OUTDOOR

Flat style fill designed specifically for outdoor use. Our CumuPlush brand is made with a special blend of poly fiber that is bonded together for comfort and resiliency.



STANDARD INDOOR

Flat style Bio Comfort® foam designed to remain firm and resilient. Indoor use only.



PREMIUM INDOOR

Bio Comfort® foam with 1" batting on the top and bottom. This will result in an additional 1"-2" of thickness due to the loft created by the batting.

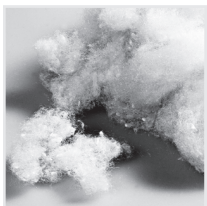

DIRECT FILL

Filled with loose poly fiber.

TUFTED OPTION

General Information

- Only available for Premium Indoor (2"-8" thick) and Direct Fill (3" and 5" thick) fill options.
- We offer one button size option — 1" (25mm) — with an indentation target of 1"-2".

Placement and Symmetry General Guidelines

- For Premium Indoor filled cushions, there is a minimum of 4 buttons per cushion regardless of size.
- **Standardized Button Placement:** Equal distance between buttons, as well as their placement relative to the cushion's edge.
 - Number of rows is determined by taking the depth and dividing it by 8", rounding down to the nearest whole number.
 - Number of buttons is determined by taking the width and dividing by 8", rounding down to the nearest whole number.
 - For trapezoidal cushions, the number of buttons is determined by adding the short and long widths; dividing their sum by 2; and then dividing that total by 8", rounding down to the nearest whole number. This is the number of buttons in the short row. Add 1 button for the long row, and for each additional row, add 1 button.
- **Customized Button Placement:** Please submit a template showing each button's placement.

D. Tie Options

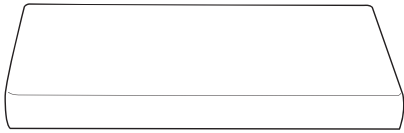

NO TIES

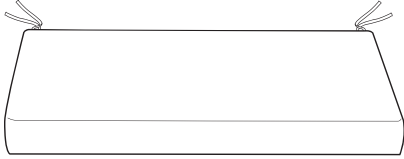

TIES ON THE BACK CORNERS

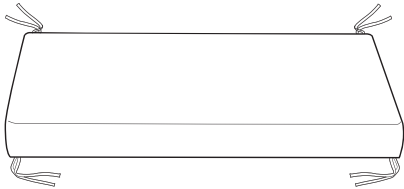

TIES ON FOUR CORNERS

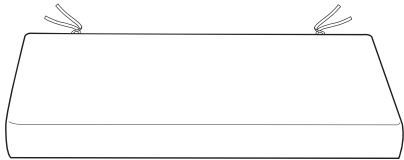

TIES ON THE BACK (INSET 4")

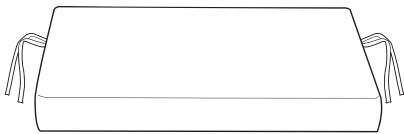

TIES ON THE LEFT AND RIGHT SIDES

Tie Options for Trapezoid Cushions

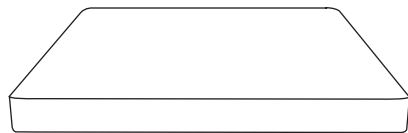

NO TIES

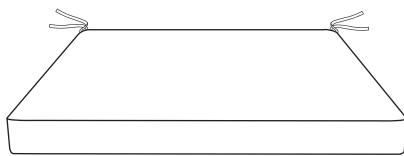

TIES ON THE BACK CORNERS

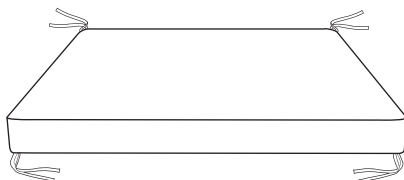

TIES ON FOUR CORNERS

E. Zipper Options

All Standard and Premium filled cushions come with "hidden" zippers. Direct Fill cushions are sewn shut.

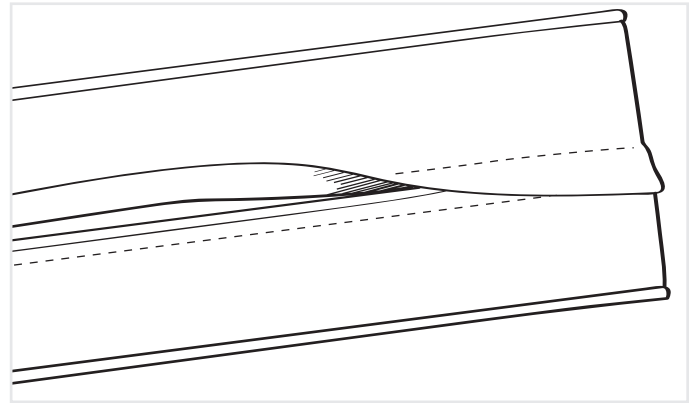

Zippers are made of nylon and come in one of three colors: beige, white, or black.

F. Thickness Options

All cushions have the option of being 2"-8" in thickness, with the exception of knife edge, which allows only 2"-3" thickness.

G. Other Notes

KNIFE EDGE RESTRICTIONS

Knife edge and single cord knife edges are only available on cushions that are 2" or 3" in thickness. Any cushions 4" or greater in thickness must have boxed edges.

EXTRA LONG CUSHIONS

All cushions that exceed 106" in length will be folded at half the length to allow for easier shipment. Cushions that are folded will take time to settle out. If you would prefer your cushion shipped flat, we recommend calling our office at 800.510.8325 and requesting your cushion not to be folded. Please note this will incur higher shipping fees. You may also want to consider ordering two separate cushions for your furniture if your project exceeds 106" in length. This can be accomplished by dividing your total length by two. **Note: All cushions 5" in thickness or greater cannot be folded and will be require additional shipping fees.**

CUSTOM SHAPE CUSHIONS

If you have a unique cushion that will require something other than our standard shapes, please refer to the Cushion Measuring Guides found in the back of this section.

MAXIMUM CUSHION DIMENSIONS

Cushions can be made up to 120" wide and 80" deep.

DIRECTIONAL FABRICS

We run all directional fabrics vertical (front to back) on a product unless otherwise stated. Please note that vertical run fabrics may cause seams on cushions longer than 50".

H. Order Dimensions & Summary of Steps

Below is a review of the entire cushion order process.

A. STYLE OPTIONS

- Shape Options
 - » Rectangle
 - » Standard Rounded Corners
 - » Standard Rounded Front Corners
 - » Standard Rounded Back Corners
 - » Trapezoid
 - » Custom Shape

- Corner Options
 - » Squared Corner
 - » Rounded Corner

B. EDGING OPTIONS

- Box Edge
- Double Cord Box Edge
- Knife Edge
- Single Cord Knife Edge

C. FILL OPTIONS

- Fill Options
 - » Standard Outdoor
 - » Standard Indoor
 - » Premium Indoor
 - » Direct Fill
- Tufted Option
 - » Thickness
 - » Standard button or COM button
 - » Standardized Button Placement or Customized Button Placement

D. TIE OPTIONS

- Standard Tie Options
 - » No Ties
 - » Ties on the back corners
 - » Ties on four corners
 - » Ties on back (inset 4")
 - » Ties on the left and right sides
- Trapezoid Tie Options
 - » No Ties
 - » Ties on the back corners
 - » Ties on four corners

E. ZIPPER OPTIONS

- Beige
- White
- Black

F. THICKNESS OPTIONS

- Box Edge: 2"-8"
- Knife Edge: 2"-3"

G. DIMENSIONS

- Width
- Depth
- Thickness

H. CHOOSE FABRIC OPTION

- Reference the Fabric Library in the back or our Online Fabric Tool, or provide COM Fabric



SINGLE & DOUBLE CHAISE CUSHIONS



Chaise lounge chairs are typically used in outdoor patio settings. Most chaise cushions are 3”-4” in thickness and are most commonly made with boxed edge styling or boxed with double cording styling. Chaises can be either single or double. Chaise cushions contain 1-3 breaks — separate cushions that are joined either with single or multiple pieces of fabric or joined with a pinched pleat seam.

A. Style Options

SHAPE OPTIONS – SINGLE CHAISE

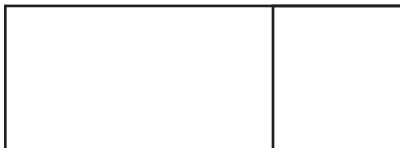

RECTANGLE
(1 BREAK)

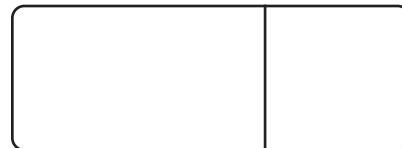

STANDARD
ROUNDED
CORNERS
(1 BREAK)



RECTANGLE
(2 BREAKS)

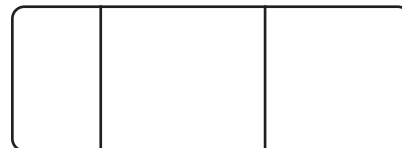

STANDARD
ROUNDED
CORNERS
(2 BREAKS)

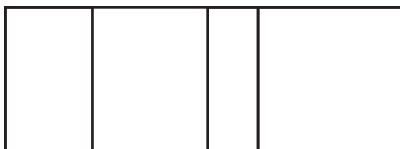

RECTANGLE
(3 BREAKS)

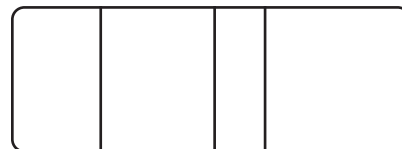

STANDARD
ROUNDED
CORNERS
(3 BREAKS)



CUSTOM
SHAPE

SHAPE OPTIONS – DOUBLE CHAISE

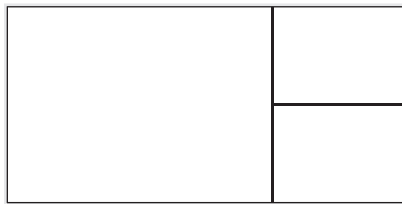

DOUBLE
CHAISE
RECTANGLE

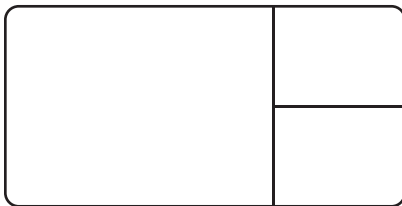

DOUBLE
CHAISE
ROUNDED
CORNERS

CORNER OPTIONS

Square Corners

- Fabric is cut at a 90° angle with ½” seam allowance.

Rounded Corners

- All standard radii are 4”.

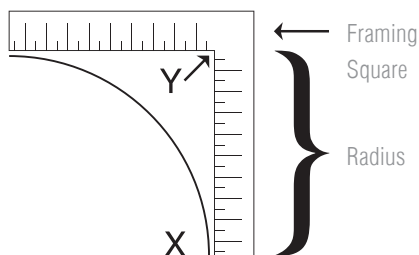

- What this means is that if you take a framing square and place it so that it is along the edges of your corners (see image above) and measure from where the curve starts to the corner of the square, that measurement will be the radius of your cushion's corners. Most furniture with rounded corners will conform to these specifications. If you require a different radius, please order a custom shaped cushion.
- **Note:** Due to the sewing style required, rounded cushions can only have boxed edges.

B. Edging Options

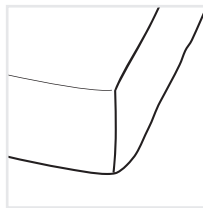

BOX EDGE

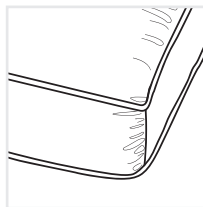

DOUBLE CORD BOX EDGE

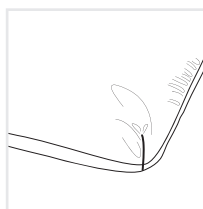

KNIFE EDGE

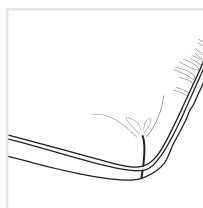

SINGLE CORD KNIFE EDGE

C. Fill Options

FILL OPTIONS

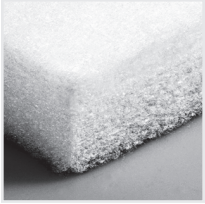

STANDARD OUTDOOR

Flat style fill designed specifically for outdoor use. Our CumuPlush brand is made with a special blend of poly fiber that is bonded together for comfort and resiliency.



STANDARD INDOOR

Flat style Bio Comfort® foam designed to remain firm and resilient. Indoor use only.

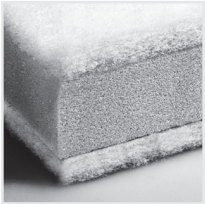

PREMIUM INDOOR

Bio Comfort® foam with 1" batting on the top and bottom. This will result in an additional 1"-2" of thickness due to the loft created by the batting.

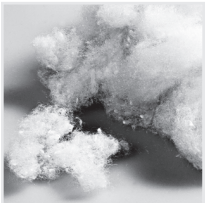

DIRECT FILL

Filled with loose poly fiber.

TUFTED OPTION

General Information

- Only available for Premium Indoor (2"-8" thick) and Direct Fill (3" and 5" thick) fill options.
- We offer one button size option — 1" (25mm) — with an indentation target of 1"-2".

Placement and Symmetry General Guidelines

- For Premium Indoor filled cushions, there is a minimum of 4 buttons per cushion regardless of size.
- **Standardized Button Placement:** Equal distance between buttons, as well as their placement relative to the cushion's edge.
 - Number of rows is determined by taking the depth and dividing it by 8", rounding down to the nearest whole number.
 - Number of buttons is determined by taking the width and dividing by 8", rounding down to the nearest whole number.
- **Customized Button Placement:** Please submit a template showing each button's placement.

D. Tie Options

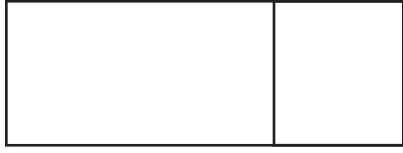

NO TIES

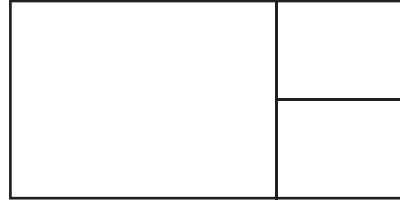

NO TIES

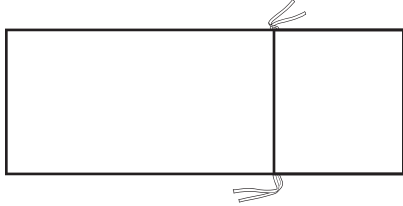

TIES ON THE FIRST BREAK

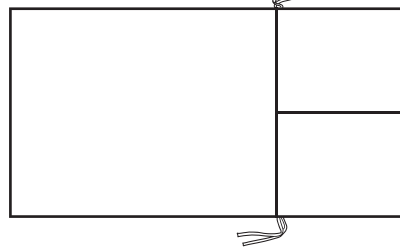

TIES ON THE FIRST BREAK

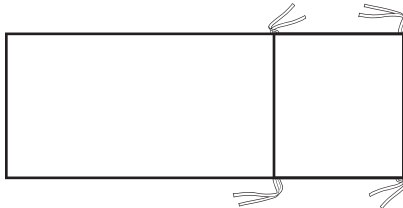

TIES ON THE TOP CORNERS AND THE FIRST BREAK

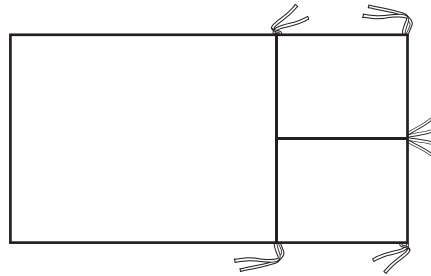

TIES ON THE TOP CORNERS AND THE FIRST BREAK

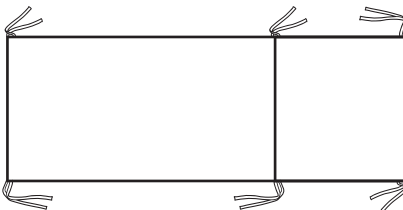

TIES ON FOUR CORNERS AND THE FIRST BREAK

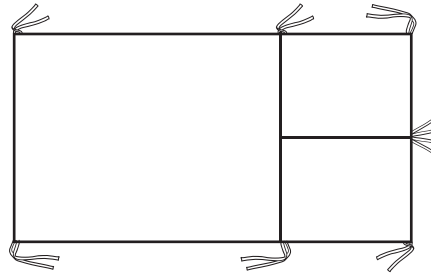

TIES ON FOUR CORNERS AND THE FIRST BREAK

E. Connection Options

JOINING PIECE

- Required on all cushions 5" thick or greater
- Finished joining piece should be 2" wide on all cushions 4" or greater in thickness; 1" wide on cushions 2" or 3" thick.

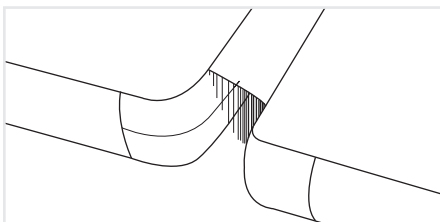

JOINING PIECE

PINCHED

- Only available on cushions 4" or less in thickness.
- Use the same amount of fabric for the ease (or "take up") as the thickness of the cushion.
 - For example: A 3" cushion will use 3" of fabric for the *ease* — the gap of fabric between the cushions that are to be joined.

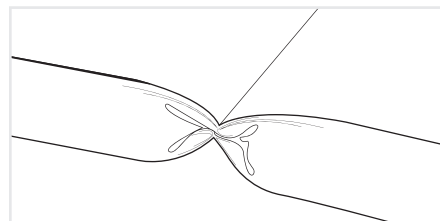

PINCHED

F. Zipper Options

All Standard and Premium filled cushions come with “hidden” zippers. Direct Fill cushions are sewn shut.

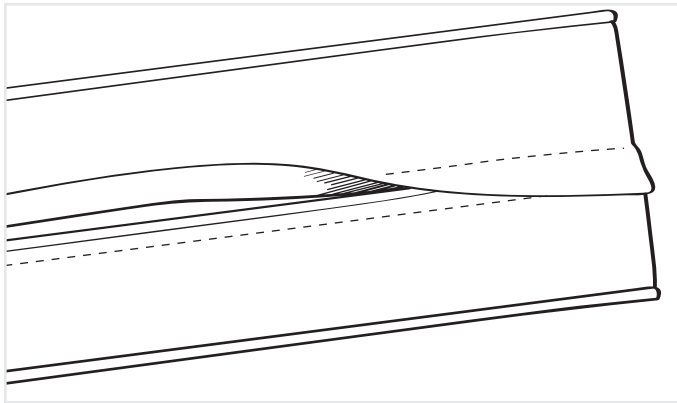

Zippers are made of nylon and come in one of three colors: beige, white, or black.

G. Thickness Options

All cushions have the option of being 2”-8” in thickness, with the exception of knife edge, which allows only 2”-3” thickness.

H. Other Notes

KNIFE EDGE RESTRICTIONS

Knife edge and single cord knife edges are only available on cushions that are 2” or 3” in thickness. Any cushions 4” or greater in thickness must have boxed edges.

EXTRA-LONG CUSHIONS

All cushions that exceed 106” in length will be folded at half the length to allow for easier shipment. Cushions that are folded will take time to settle out. If you would prefer your cushion shipped flat, we recommend calling our office at 800.510.8325 and requesting your cushion not to be folded. Please note this will incur higher shipping fees. You may also want to consider ordering two separate cushions for your furniture if your project exceeds 106” in length. This can be accomplished by dividing your total length by two. **Note: All cushions 5” in thickness or greater cannot be folded and will be require additional shipping fees.**

CUSTOM SHAPE CHAISE LOUNGE

If you have a unique chair that will require something other than our standard sizes, please refer to our Cushion Measuring Guides pages found in the back of this section.

MAXIMUM CUSHION DIMENSIONS

Cushions can be made up to 120” wide and 80” deep.

DIRECTIONAL FABRICS

We run all directional fabrics vertical (front to back) on a product unless otherwise stated. Please note that vertical run fabrics may cause seams on cushions longer than 50”.

I. Order Dimensions & Summary of Steps

Below is a review of the entire chaise and double-chaise order process. Please refer to the below guides for specifying section dimensions and number of breaks.

A. STYLE OPTIONS

- Shape Options
 - » Single/Double Chaise Rectangle (1-3 Breaks)
 - » Single/Double Chaise Rounded Corners (1-3 Breaks)
 - » Single/Double Chaise Custom Shape (1-3 Breaks)
- Corner Options
 - » Square Corners
 - » Rounded Corners

B. EDGING OPTIONS

- Box Edge
- Double Cord Box Edge
- Knife Edge
- Single Cord Knife Edge

C. FILL OPTIONS

- Fill Options
 - » Standard Outdoor
 - » Standard Indoor
 - » Premium Indoor
 - » Direct Fill
- Tufted Option
 - » Thickness
 - » Standard Button or COM Button
 - » Standardized Button Placement or Customized Button Placement

D. TIE OPTIONS

- No ties
- Ties on the first break
- Ties on the top corners and the first break
- Ties on four corners and the first break

E. CONNECTION OPTIONS

- Joining Piece
- Pinched

F. ZIPPER OPTIONS

- Beige
- White
- Black

G. THICKNESS OPTIONS

- Box Edge: 2"-8"
- Knife Edge: 2"-3"

H. DIMENSIONS

- Width
- Section 1 (Top) Depth
- Section 2 Depth
- Section 3 Depth
- Section 4 Depth
- Thickness

I. FABRIC OPTIONS

- Reference the Fabric Library in the back or our Online Fabric Tool, or provide COM Fabric

DIMENSION AND BREAK GUIDES

Single Chaise Cushion

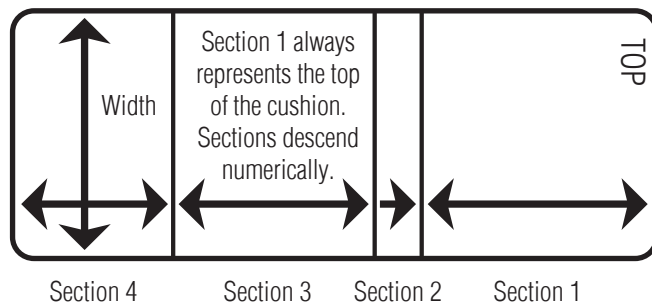

Double Chaise Cushion

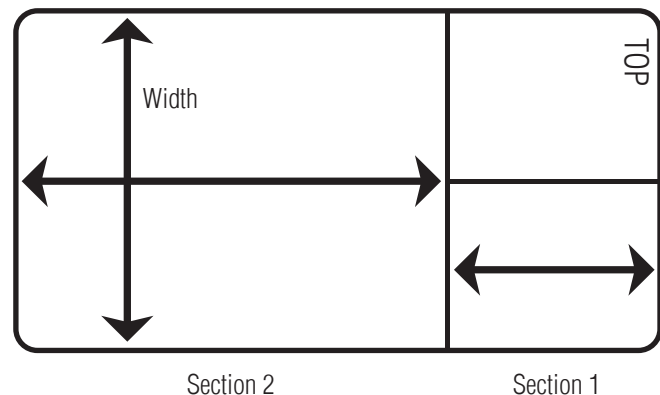



STEAMER CUSHIONS

A. Style Options

SHAPE OPTIONS

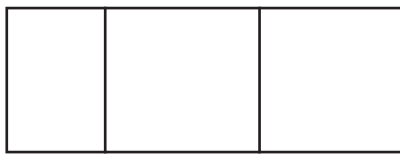

RECTANGLE
(2 BREAKS)

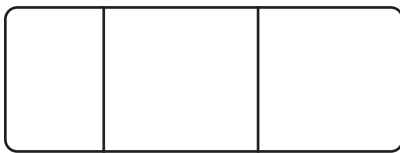

ROUNDED
CORNERS
(2 BREAKS)



CUSTOM
SHAPE
(2 BREAKS)

CORNER OPTIONS

Square Corners

Fabric is cut at a 90° angle with 1/2" seam allowance.

Rounded Cushions

All standard radii on rounded corner cushions are 4".

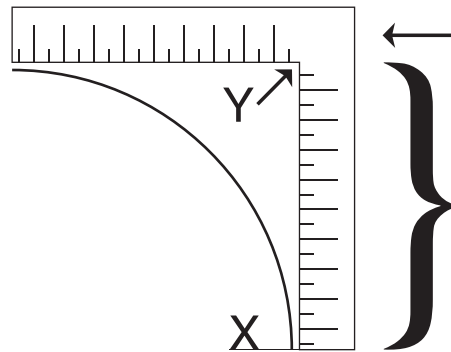

What this means is that if you take a framing square and place it so that it is along the edges of your corners (see image above) and measure from where the curve starts to the corner of the square, that measurement will be the radius of your cushion's corners. Most furniture with rounded corners will conform to these specifications. If you require a different radius, please order a custom shaped cushion.

Note: Due to the sewing style required, rounded cushions can only have boxed edges.

B. Edging Options

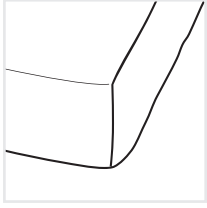

BOX EDGE

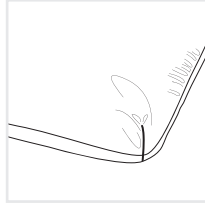

KNIFE EDGE

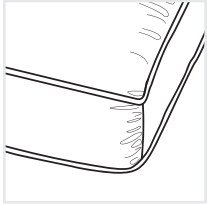

DOUBLE CORD BOX EDGE

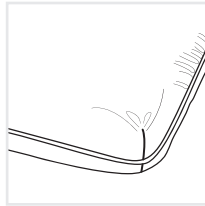

SINGLE CORD KNIFE EDGE

C. Fill Options

FILL OPTIONS

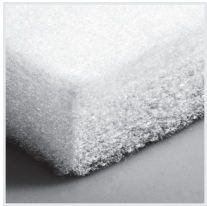

STANDARD OUTDOOR

Flat style fill designed specifically for outdoor use. Our CumuPlush brand is made with a special blend of poly fiber that is bonded together for comfort and resiliency.



STANDARD INDOOR

Flat style Bio Comfort® foam designed to remain firm and resilient. Indoor use only.



PREMIUM INDOOR

Bio Comfort® foam with 1" batting on the top and bottom. This will result in an additional 1"-2" of thickness due to the loft created by the batting.

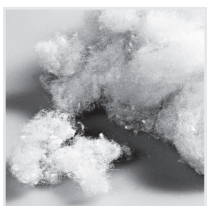

DIRECT FILL

Filled with loose poly fiber.

TUFTED OPTION

General Information

- Only available for Premium Indoor (2"-8" thick) and Direct Fill (3" and 5" thick) fill options.
- We offer one button size option — 1" (25mm) — with an indentation target of 1"-2".

Placement and Symmetry General Guidelines

- For Premium Indoor filled cushions, there is a minimum of 4 buttons per cushion regardless of size.
- **Standardized Button Placement:** Equal distance between buttons, as well as their placement relative to the cushion's edge.
 - Number of rows is determined by taking the depth and dividing it by 8", rounding down to the nearest whole number.
 - Number of buttons is determined by taking the width and dividing by 8", rounding down to the nearest whole number.
- **Customized Button Placement:** Please submit a template showing each button's placement.

D. Tie Options



NO TIES

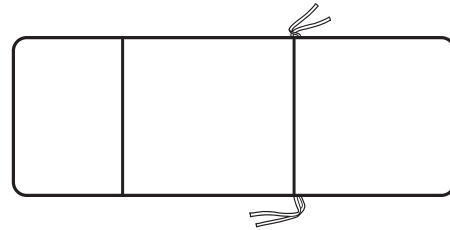

TIES ON THE FIRST BREAK

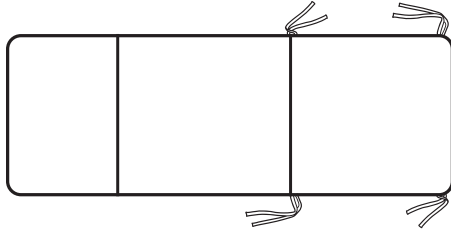

TIES ON THE TOP CORNERS AND THE FIRST BREAK

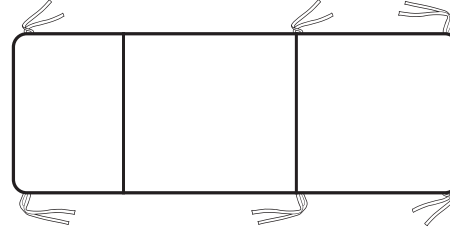

TIES ON FOUR CORNERS AND THE FIRST BREAK

E. Connection Options

JOINING PIECE

- Required on all cushions 5" thick or greater
- Finished joining piece should be 2" wide on all cushions 4" or greater in thickness; 1" wide on cushions 2" or 3" thick.

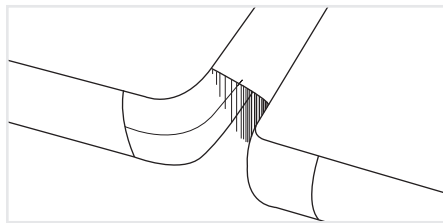

JOINING PIECE

PINCHED

- Only available on cushions 4" or less in thickness.
- Use the same amount of fabric for the ease (or "take up") as the thickness of the cushion.
 - For example: A 3" cushion will use 3" of fabric for the *ease* — the gap of fabric between the cushions that are to be joined.

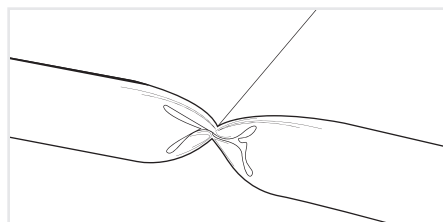

PINCHED

F. Zipper Options

All standard and premium filled cushions come with "hidden" zippers. Direct Fill cushions are sewn shut.

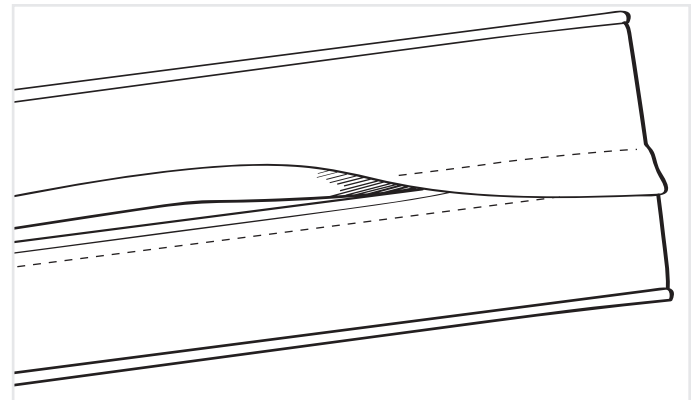

Zippers are made of nylon and come in one of three colors: beige, white, or black.

G. Thickness Options

All cushions have the option of being 2"-8" in thickness, with the exception of knife edge, which allows only 2"-3" thickness.

H. Other Notes

KNIFE EDGE RESTRICTIONS

Knife edge and single cord knife edges are only available on cushions that are 2" or 3" in thickness. Any cushions 4" or greater in thickness must have boxed edges.

EXTRA-LONG CUSHIONS

All cushions that exceed 106” in length will be folded at half the length to allow for easier shipment. Cushions that are folded will take time to settle out. If you would prefer your cushion shipped flat, we recommend calling our office at 800.510.8325 and requesting your cushion not to be folded. Please note this will incur higher shipping fees. You may also want to consider ordering two separate cushions for your furniture if your project exceeds 106” in length. This can be accomplished by dividing your total length by two. **Note: All cushions 5” in thickness or greater cannot be folded and will require additional shipping fees.**

CUSTOM SHAPE CUSHIONS

If you have a unique cushion that will require something other than our standard shapes, please refer to the Cushion Measuring Guide pages found in the back of this section.

MAXIMUM CUSHION DIMENSIONS

Cushions can be made up to 120” wide and 80” deep.

DIRECTIONAL FABRICS

We run all directional fabrics vertical (front to back) on a product unless otherwise stated. Please note that vertical run fabrics may cause seams on cushions longer than 50”.

I. Order Dimensions & Summary of Steps

Below is a review of the entire steamer cushion order process, including a guide for specifying section dimensions and number of breaks.

A. STEAMER SHAPE OPTIONS

- Rectangle (2 Breaks)
- Rounded Corners (2 Breaks)
- Custom Shape (2 Breaks)

F. ZIPPER OPTIONS

- Beige
- White
- Black

B. EDGING OPTIONS

- Box Edge
- Double Cord Box Edge
- Knife Edge
- Single Cord Knife Edge

G. THICKNESS OPTIONS

- Box Edge: 2”-8”
- Knife Edge: 2”-3”

C. FILL OPTIONS

- Fill Options
 - » Standard Outdoor
 - » Standard Indoor
 - » Premium Indoor
 - » Direct Fill
- Tufted Option
 - » Thickness
 - » Standard Button or COM Button
 - » Standardized or Customized Button Placement

H. DIMENSIONS

- Width
- Section 1 (Top) Depth
- Section 2 Depth
- Section 3 Depth
- Thickness

I. FABRIC OPTIONS

- Reference the Fabric Library in the back or our Online Fabric Tool, or provide COM Fabric

D. TIE OPTIONS

- No ties
- Ties on the first break
- Ties on the top corners and the first break
- Ties on four corners and the first break

DIMENSION AND BREAK GUIDES

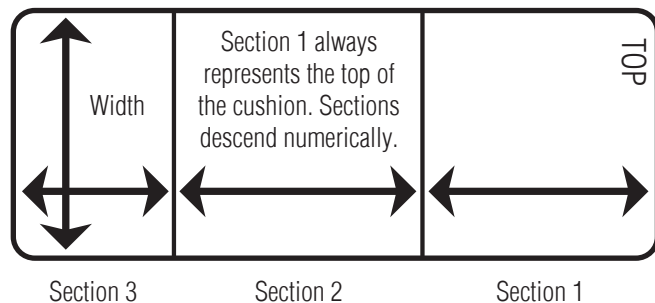

E. CONNECTION OPTIONS

- Joining Piece
- Pinched



OTTOMAN CUSHIONS

A. Style Options

SHAPE OPTIONS

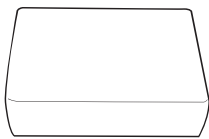

RECTANGLE

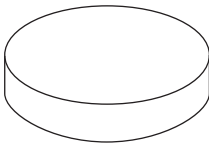

ROUND

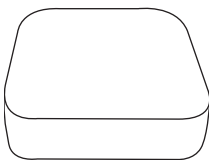

STANDARD ROUNDED CORNERS

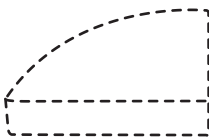

CUSTOM SHAPE

CORNER OPTIONS

Square Corners

- Fabric is cut at a 90° angle with 1/2" seam allowance.

Rounded Corners

- All standard radii are 4".

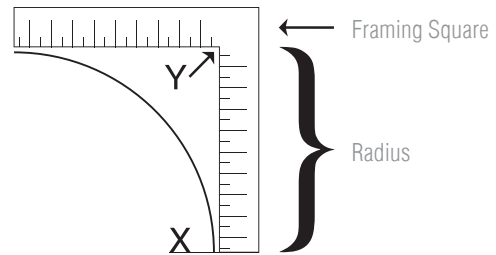

- What this means is that if you take a framing square and place it so that it is along the edges of your corners (see image above) and measure from where the curve starts to the corner of the square, that measurement will be the radius of your cushion's corners. Most furniture with rounded corners will conform to these specifications. If you require a different radius, please order a custom shaped cushion.
- **Note:** Due to the sewing style required, rounded cushions can only have boxed edges.

B. Edging Options

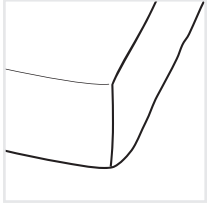

BOX EDGE

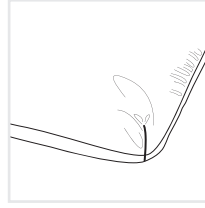

KNIFE EDGE

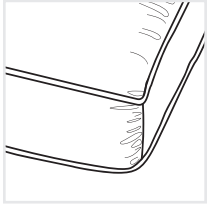

DOUBLE CORD BOX EDGE

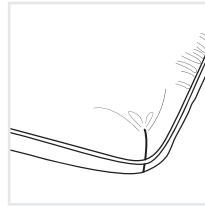

SINGLE CORD KNIFE EDGE

C. Fill Options

FILL CHOICES – SEAT AND BACK

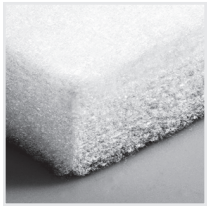

STANDARD OUTDOOR

Flat style fill designed specifically for outdoor use. Our CumuPlush brand is made with a special blend of poly fiber that is bonded together for comfort and resiliency.



STANDARD INDOOR

Flat style Bio Comfort® foam designed to remain firm and resilient. Indoor use only.



PREMIUM INDOOR

Bio Comfort® foam with 1” batting on the top and bottom. This will result in an additional 1”-2” of thickness due to the loft created by the batting.

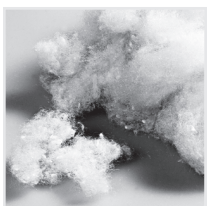

DIRECT FILL

Filled with loose poly fiber.

TUFTED STYLE CUSHIONS

General Information

- Only available for Premium Indoor (2”-8” thick) and Direct Fill (3” and 5” thick) fill options.
- We offer one button size option — 1” (25mm) — with an indentation target of 1”-2”.

Placement and Symmetry General Guidelines

- For Premium Indoor filled cushions, there is a minimum of 4 buttons per cushion regardless of size.
- **Standardized Button Placement:** Equal distance between buttons, as well as their placement relative to the cushion’s edge.
 - Number of rows is determined by taking the depth and dividing it by 8”, rounding down to the nearest whole number.
 - Number of buttons is determined by taking the width and dividing by 8”, rounding down to the nearest whole number.
- **Customized Button Placement:** Please submit a template showing each button’s placement.

D. Tie Options

Tie Options for Rectangle Cushions

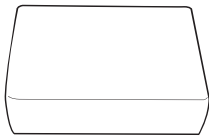

NO TIES

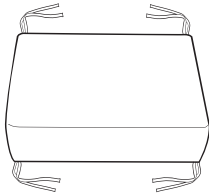

TIES ON
FOUR
CORNERS

Tie Options for Round Cushions

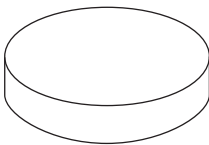

NO TIES

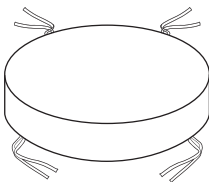

TIES ON
THE FRONT
AND BACK

E. Zipper Options

All Standard and Premium filled cushions come with “hidden” zippers. Direct Fill cushions are sewn shut.

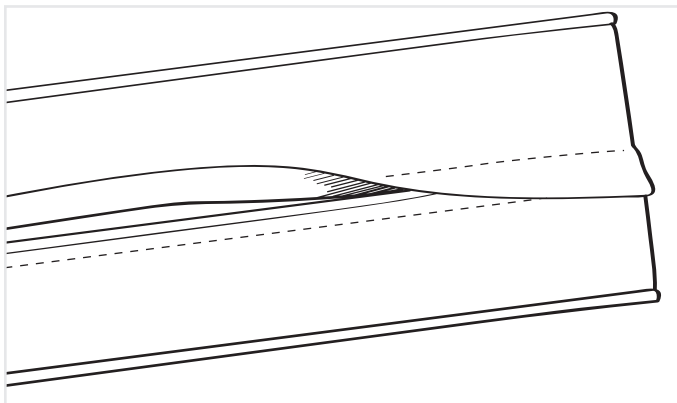

Zippers are made of nylon and come in one of three colors: beige, white, or black.

F. Thickness Options

All cushions have the option of being 2”-8” in thickness, with the exception of knife edge, which allows only 2”-3” thickness.

G. Other Notes

KNIFE EDGE RESTRICTIONS

Knife edge and single cord knife edges are only available on cushions that are 2” or 3” in thickness. Any cushions 4” or greater in thickness must have boxed edges.

CUSTOM SHAPE CUSHIONS

If you have a unique cushion that will require something other than our standard sizes, please refer to Cushion Measuring Guides found in the back of this section.

DIRECTIONAL FABRICS

We run all directional fabrics vertical (front to back) on a product unless otherwise stated. Please note that vertical run fabrics may cause seams on cushions longer than 50”.

H. Order Dimensions & Summary of Steps

Below is a review of the entire ottoman cushion order process.

A. STYLE OPTIONS

- Shape Options
 - » Rectangle
 - » Standard Rounded Corners
 - » Round
 - » Custom Shape
- Corner Options
 - » Square Corners
 - » Rounded Corners

B. EDGING OPTIONS

- Box Edge
- Double Cord Box Edge
- Knife Edge
- Single Cord Knife Edge

C. FILL OPTIONS

- Fill Options
 - » Standard Outdoor
 - » Standard Indoor
 - » Premium Indoor
 - » Direct Fill
- Tufted Option
 - » Thickness
 - » Standard Button or COM Button
 - » Standardized Button Placement or Customized Button Placement

D. TIE OPTIONS

- Standard Tie Options
 - » No ties
 - » Ties on all corners
- Round Tie Options
 - » No ties
 - » Ties on the front and back

E. ZIPPER OPTIONS

- Beige
- White
- Black

F. THICKNESS OPTIONS

- Box Edge: 2"-8"
- Knife Edge: 2"-3"

G. DIMENSIONS

- Rectangular Shape Options
 - » Width
 - » Depth
 - » Thickness
- Round Shape Options
 - » Diameter
 - » Thickness

H. FABRIC OPTIONS

- Reference the Fabric Library in the back or our Online Fabric Tool, or provide COM Fabric



DEEP SEATING CUSHIONS

A. Style Options

SHAPE OPTIONS

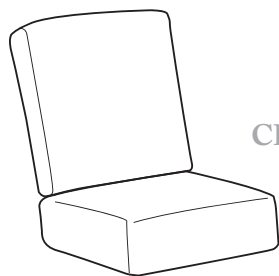

CHAIR

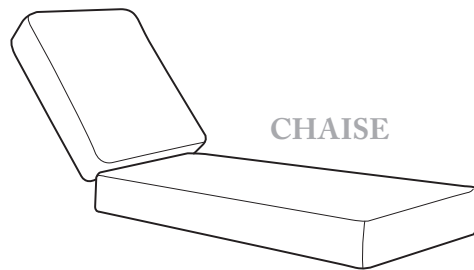

CHAISE

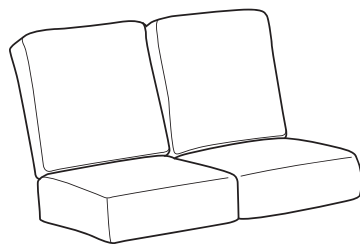

LOVESEAT

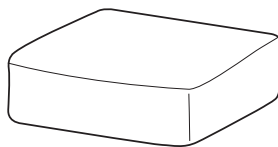

OTTOMAN

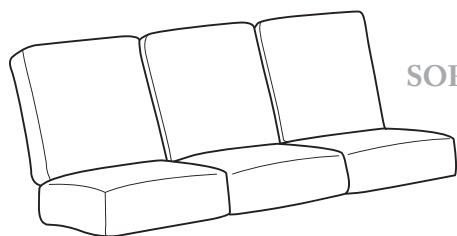

SOFA

CORNER OPTIONS

Square Corners

- Fabric is cut at a 90° angle with 1/2" seam allowance.

Rounded Corners

- All standard radii are 4".

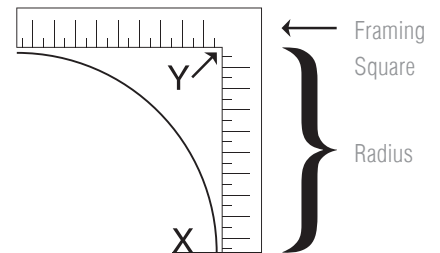

- What this means is that if you take a framing square and place it so that it is along the edges of your corners (see image above) and measure from where the curve starts to the corner of the square, that measurement will be the radius of your cushion's corners. Most furniture with rounded corners will conform to these specifications. If you require a different radius, please order a custom shaped cushion.
- **Note:** Due to the sewing style required, rounded cushions can only have boxed edges.

B. Edging Options

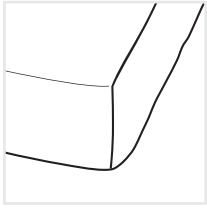

BOX EDGE

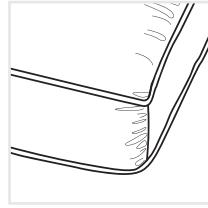

DOUBLE CORD BOX EDGE

C. Fill Options

FILL OPTIONS – SEAT AND BACK



STANDARD OUTDOOR

Flat style fill designed specifically for outdoor use. Our CumuPlush brand is made with a special blend of poly fiber that is bonded together for comfort and resiliency.



STANDARD INDOOR

Flat style Bio Comfort® foam designed to remain firm and resilient. Indoor use only.



PREMIUM INDOOR

Bio Comfort® foam with 1” batting on the top and bottom. This will result in an additional 1”-2” of thickness due to the loft created by the batting.

FILL OPTIONS – BACK ONLY

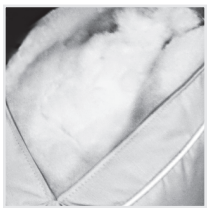

PLUSH

Plush style fill consists of two sheets of batting sandwiching a loose poly fiber fill. The batting gives the necessary rigidity for holding the cushion’s shape, while the loose poly fiber offers a luxurious, “plush” appeal.

TUFTED OPTION

General Information

- Only available for back cushions with the Plush fill.
- We offer one button size option — 1” (25mm) — with an indentation target of 1”-2”.

Placement and Symmetry General Guidelines

- “Plush” back cushion button options: no buttons, 1 button, 4 buttons, or 5 buttons.
- Back cushion button placements:
 - 1 Button: centered.
 - 4 Buttons: equidistant and centered in a box or diamond pattern.
 - 5 Buttons: 4 buttons equidistant and centered in a box or diamond pattern, with the last button centered inside the 4-button pattern.

D. Zipper Options

All Standard and Premium filled cushions come with “hidden” zippers. Direct Fill cushions are sewn shut.

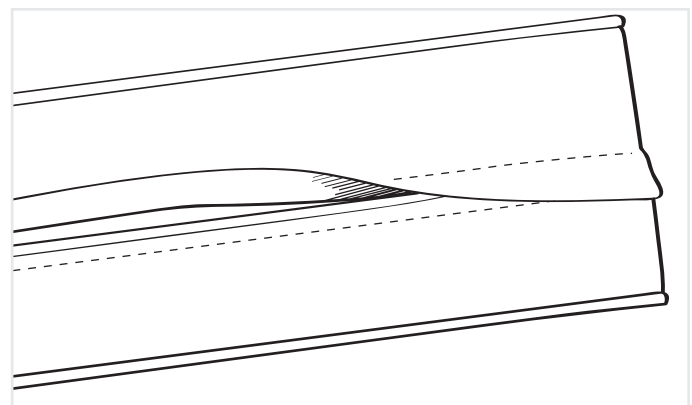

Zippers are made of nylon and come in one of three colors: beige, white, or black.

E. Thickness Options

All cushions have the option of being 2"-8" in thickness.

F. Other Notes

EXTRA-LONG CUSHIONS

All cushions that exceed 106" in length will be folded at half the length to allow for easier shipment. Cushions that are folded will take time to settle out. If you would prefer your cushion shipped flat, we recommend calling our office at 800.510.8325 and requesting your cushion not to be folded. Please note this will incur higher shipping fees. You may also want to consider ordering two separate cushions for your furniture if your project exceeds 106" in length. This can be accomplished by dividing your total length by two. **Note: All cushions 5" in thickness or greater cannot be folded and will be require additional shipping fees.**

CUSTOM SHAPE CUSHIONS

If you have a unique cushion that will require something other than our standard shapes, please refer to the Cushion Measuring Guides found in the back of this section.

CUSHION MAXIMUM DIMENSIONS

Cushions can be made up to 120" wide and 80" deep.

DIRECTIONAL FABRICS

We run all directional fabrics vertical (front to back) on a product unless otherwise stated. Please note that vertical run fabrics may cause seams on cushions longer than 50".

G. Order Dimensions & Summary of Steps

Below is a review of the entire chair and seat cushion order process.

A. STYLE OPTIONS

- Chair
- Chaise
- Loveseat
- Ottoman
- Sofa

B. EDGING OPTIONS

- Box Edge
- Double Cord Box Edge

C. FILL OPTIONS

- Fill Options
 - » Standard Outdoor
 - » Standard Indoor
 - » Premium Indoor
- Tufted Option (Back only)
 - » Thickness
 - » Standard Button or COM Button
 - » Standardized Button Placement

D. ZIPPER OPTIONS

- Beige
- White
- Black

E. THICKNESS OPTIONS

- Box Edge: 2"-8"

F. DIMENSIONS

- Chair
 - » Width
 - » Depth
 - » Thickness
- Chaise
 - » Width
 - » Section 1 (Top) Depth
 - » Section 2 Depth
 - » Thickness
- Loveseat
 - » Total Width (Optionally divided equally by 2 for back and seat cushions.)
 - » Back Height
 - » Seat Depth
 - » Thickness
- Ottoman
 - » Width
 - » Depth
 - » Thickness
- Sofa
 - » Total Width (Optionally divided equally by 3 for back and seat cushions.)
 - » Back Height
 - » Seat Depth
 - » Thickness

G. FABRIC OPTIONS

- Reference the Fabric Library in the back or our Online Fabric Tool, or provide COM Fabric



WICKER, RATTAN & SETTEE CUSHIONS



A. Cushion Shape Options

SHAPE OPTIONS

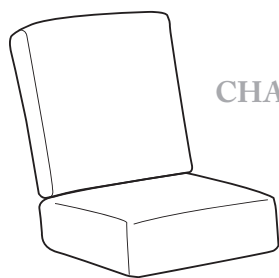

CHAIR

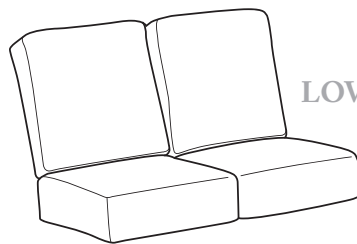

LOVESEAT

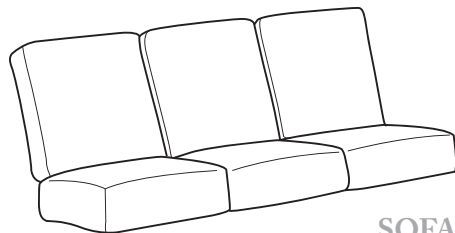

SOFA

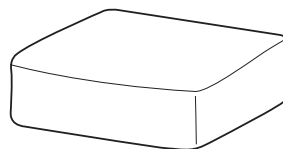

OTTOMAN

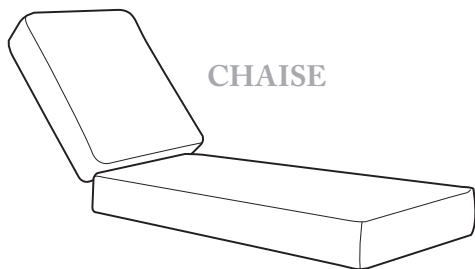

CHAISE

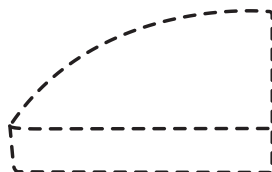

CUSTOM SHAPE

CORNER OPTIONS

Square Corners

- Fabric is cut at a 90° angle with ½” seam allowance.

Rounded Corners

- All standard wicker radii are 8”.

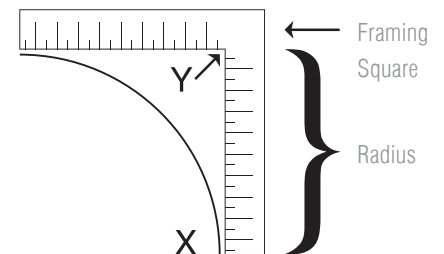

- What this means is that if you take a framing square and place it so that it is along the edges of your corners (see image above) and measure from where the curve starts to the corner of the square, that measurement will be the radius of your cushion’s corners. Most furniture with rounded corners will conform to these specifications. If you require a different radius, please order a custom shaped cushion.
- Note:** Due to the sewing style required, rounded cushions can only have boxed edges.

B. Create Your Template

A template will be required for all wicker furniture cushions. Please refer to the Cushion Measuring Guides found in the back of this section. Please provide a template to define your specific cushion shape, as well as the outer cushion dimensions, to ensure accurate pricing and fit.

B. Edging Options

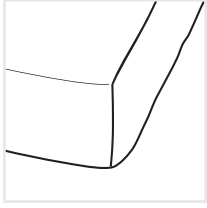

BOX EDGE

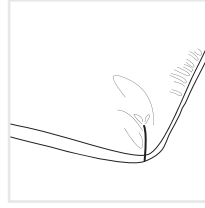

KNIFE EDGE

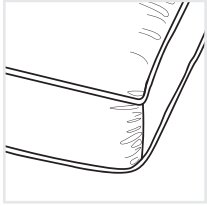

DOUBLE CORD BOX EDGE

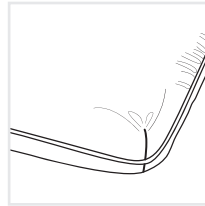

SINGLE CORD KNIFE EDGE

C. Fill Options

FILL OPTIONS – SEAT AND BACK

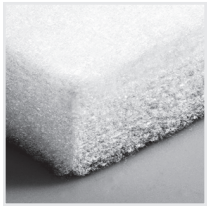

STANDARD OUTDOOR

Flat style fill designed specifically for outdoor use. Our CumuPlush brand is made with a special blend of poly fiber that is bonded together for comfort and resiliency.



STANDARD INDOOR

Flat style Bio Comfort® foam designed to remain firm and resilient. Indoor use only.



PREMIUM INDOOR

Bio Comfort® foam with 1” batting on the top and bottom. This will result in an additional 1”-2” of thickness due to the loft created by the batting.

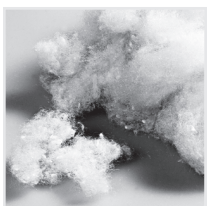

DIRECT FILL

Filled with loose poly fiber.

FILL OPTION – BACK-ONLY

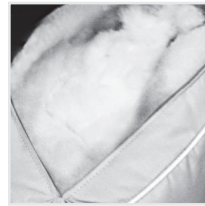

PLUSH

Plush style fill consists of two sheets of batting sandwiching a loose poly fiber fill. The batting gives the necessary rigidity for holding the cushion’s shape, while the loose poly fiber offers a luxurious, “plush” appeal.

TUFTED OPTION

General Information

- Only available for Premium Indoor (2”-8” thick) and Direct Fill (3” and 5” thick) fill options.
- We offer one button size option — 1” (25mm) — with an indentation target of 1”-2”.

Placement and Symmetry General Guidelines

- **Number of Buttons:** For Premium Indoor filled cushions, there is a minimum of 4 buttons per cushion regardless of size. “Plush” back cushion button options: no buttons, 1 button, 4 buttons, or 5 buttons.
- **Standardized Button Placement:** Equal distance between buttons, as well as their placement relative to the cushion’s edge.
 - Number of rows is determined by taking the depth and dividing it by 8”, rounding down to the nearest whole number.
 - Number of buttons is determined by taking the width and dividing by 8”, rounding down to the nearest whole number.

D. Tufted Option continued

- For trapezoidal cushions, the number of buttons is determined by adding the short and long widths; dividing their sum by 2; and then dividing that total by 8", rounding down to the nearest whole number. This is the number of buttons in the short row. Add 1 button for the long row, and for each additional row, add 1 button.
- Back cushion button placements:
 - » 1 Button: centered.
 - » 4 Buttons: equidistant and centered in a box or diamond pattern.
 - » 5 Buttons: 4 buttons equidistant and centered in a box or diamond pattern, with the last button centered inside the 4-button pattern.
- **Customized Button Placement:** Please submit a template showing each button's placement.

E. Zipper Options

All Standard and Premium filled cushions come with "hidden" zippers. Direct Fill only cushions are sewn shut.

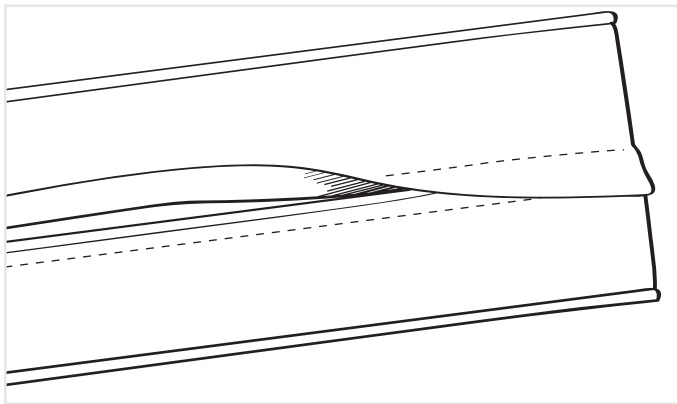

Zippers are made of nylon and come in one of three colors: beige, white, or black.

F. Thickness Options

All cushions have the thickness options of 3", 5", or 7".

G. Other Notes

KNIFE EDGE RESTRICTIONS

Knife edge and single cord knife edges are only available on cushions that are 3" in thickness. Any cushions 4" or greater in thickness must have boxed edges.

EXTRA-LONG CUSHIONS

All cushions that exceed 106" in length will be folded at half the length to allow for easier shipment. Cushions that are folded will take time to settle out. If you would prefer your cushion shipped flat, we recommend calling our office at 800.510.8325 and requesting your cushion not to be folded. Please note this will incur higher shipping fees. You may also want to consider ordering two separate cushions for your furniture if your project exceeds 106" in length. This can be accomplished by dividing your total length by two. **Note: All cushions 5" in thickness or greater cannot be folded and will require additional shipping fees.**

MAXIMUM CUSHION DIMENSIONS

Cushions can be made up to 120" wide and 80" deep.

DIRECTIONAL FABRICS

We run all directional fabrics vertical (front to back) on a product unless otherwise stated. Please note that vertical run fabrics may cause seams on cushions longer than 50".

H. Order Dimensions & Summary of Steps

Below is a review of the entire wicker, rattan and sette cushion order process.

A. STYLE OPTIONS

- Shape Options
 - » Chair
 - » Ottoman
 - » Love Seat
 - » Sofa
 - » Chaise
 - » Custom Shape
- Corner Options
 - » Square Corners
 - » Rounded Corners

B. CREATE YOUR TEMPLATE

- Reference Cushion Measurement Guides in back.

C. EDGING OPTIONS

- Box Edge
- Double Cord Box Edge
- Knife Edge
- Single Cord Knife Edge

D. FILL OPTIONS

- Fill Options
 - » Standard Outdoor
 - » Standard Indoor
 - » Premium Indoor
 - » Direct Fill
- Optional Tufting Style:
 - » Thickness
 - » Standard Button or COM Button
 - » Standardized Button Placement or Customized Button Placement

E. ZIPPER OPTIONS

- Beige
- White
- Black

F. THICKNESS OPTIONS

- Box Edge: 3", 5", and 7"
- Knife Edge: 3"

G. DIMENSIONS

- Width
- Depth
- Thickness

H. FABRIC OPTION

- Reference the Fabric Library in the back or our Online Fabric Tool, or provide COM Fabric



CUSHION MEASURING GUIDES

We offer a custom measurement cushion guide for the following cushion styles: bench, window seat, chair, and chaise lounge, as well as overstuffed cushions for wicker, rattan, and settees.

We pride ourselves in creating beautiful custom cushions using the templates you provide. Because our cushions are made in half-inch width and depth increments, please round to the nearest half inch. Measuring, at this point, is critical. To ensure a proper fit, please follow the guide below. Please note: when using an existing seat cushion, use a straight ruler to get an accurate measurement.

DEPTH (Front to Back)

When measuring depth, start at the front of the seat and measure backward to the back.

WIDTH (Side to Side)

When measuring width, measure side to side. This will provide us with an outer dimension of your cushion.

THICKNESS

Determine the thickness you want in 1" increments. Cushion thickness choices range from 2" to 8".

Chair Cushions

Note: Remember to subtract the thickness of the bottom from the length of the back cushion. Please measure all chair cushions carefully, paying close attention to special shapes and sizes.

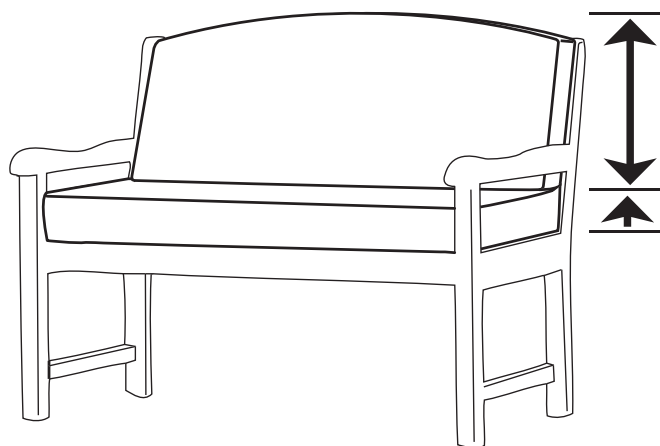

Wicker Cushions, Rattan, Settee (Overstuffed)

Your template will be required for all wicker furniture cushions.

Reference the cushion template steps on the next page to ensure you receive a proper fit.

Please provide a template to define your specific cushion shape, as well as the outer cushion dimensions, to ensure accurate pricing and fit.

Note: Widths vary from the front and back. Please check both ends to confirm your measurement.

Creating a Cushion Template

If your cushion is NOT square, rectangular, or a shape shown online, it will require a template. Please use thick butcher paper or cloth to create a reliable template.

TEMPLATE INFORMATION

Write the following information on your template:

- Full Name
- Invoice Number
- Thickness
- Quantity
- Fabric Choice (Specify which side if reversible)
- Cording Option
- Zipper Location
- Tie and Break Locations

As cushions and fabrics age, the shape of a cushion can become less than symmetrical. To ensure a symmetrical template, fold it down the middle and cut as needed to balance the pattern. Double-check your new template with your furniture.

MAIL YOUR TEMPLATE TO:

Designer Custom Source
Attn: Template Order
3180 Wetumpka Highway
Montgomery, AL 36110

Existing cushion shells cannot be used as templates.

How to Create a Pattern From an Existing Cushion

STEP 1

Place your cushion on top of thick butcher paper or cloth.

STEP 2

Trace around the cushion and cut out the shape.

STEP 3

Test your template for fit. If adjustments are needed, please make sure to securely tape the paper together. Only one pattern is needed for each cushion shape.

How to Create a Template from Your Furniture (Without a Cushion)

STEP 1

Lay out a sheet of paper on the furniture piece. Firmly press the paper flat to fit the outside edges of your furniture.

STEP 2

Trace the outside edges to match your new cushion shape. This template becomes the exact shape and size of your custom-made cushion.

STEP 3

Once your pattern has been cut, test for an accurate fit. If adjustments are needed, please make sure to securely tape the paper together. Only one pattern is needed for each cushion shape. Please double-check all measurements.



FABRIC YARDAGE GUIDE

How to Determine Fabric Requirements

LENGTH

Length is the sum of the longest side's measurement; the product of your thickness multiplied by 2; and the product of multiplying the number of breaks by thickness, then by 2. If ties, include an additional 2".

DEPTH

If the sum of the depth's (short side) measurement and the thickness is greater than 25", double the fabric allot for your "length" measurement above.

If the sum of the depth's measurement and the thickness is greater than 52", then multiply the width by 2.6.

This is considered your "adjusted depth."

FABRIC REPEATS

"X" equals the horizontal measurement of a fabric repeat.
"Y" is the vertical measurement of a fabric repeat.

When the sum of X and Y is greater than 2" and less than or equal to 14", multiply its adjusted depth by 1.1.

When the sum of X and Y is greater than 14" and less than or equal to 19", multiply its adjusted depth by 1.15.

When the sum of X and Y is greater than 19" and less than or equal to 27", multiply its adjusted depth by 1.2.

When the sum of X and Y is greater than 27" and less than or equal to 36", multiply its adjusted depth by 1.25.

When the sum of X and Y is greater than 36" and less than or equal to 45", multiply its adjusted depth by 1.3.

When the sum of X and Y is greater than 45", multiply its adjusted depth by 1.35.

Treat cording separate regardless if it is the same as the main fabric and order a minimum of 1 yard.

DIRECTIONAL FABRICS

We run all directional fabrics vertical (front to back) on a product unless otherwise stated. Please note that vertical run fabrics may cause seams on cushions longer than 50".

Fabric Yardage Measurement Examples

SEAT CUSHION

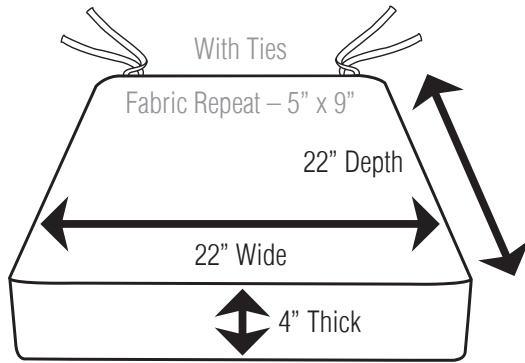

Length

$22''$ (longest side) + $8''$ ($4''$ thickness x 2) + $2''$ (ties) = $32''$ Length

Depth

$22''$ (short side) + $4''$ (thickness) = $26''$ Depth
Since $26''$ is greater than $25''$, double its length to $64''$ (adjusted length).

Fabric Repeat

$5'' + 9''$ equals $14''$, thus you will multiply your adjusted length by 1.1 for a total of $70.40''$. Divide $70.40''$ by $36''$ for a total of 1.96 yards. Round this number to 2 yards.

Cording

Provide 1 yard.

Total Amount of Fabric

Send a total of 3 yards.

BENCH CUSHION

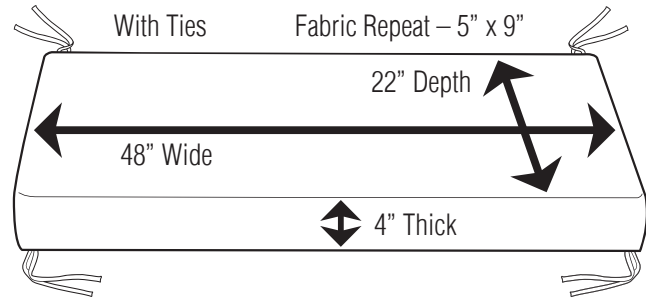

Length

$48''$ (longest side) + $8''$ ($4''$ thickness x 2) + $2''$ (ties) = $58''$ Length

Depth

$22''$ (short side) + $4''$ (thickness) = $26''$ Depth
Since $26''$ is greater than $25''$, double its length to $116''$ (adjusted length).

Fabric Repeat

$5'' + 9''$ equals $14''$, thus you will multiply your adjusted length by 1.1 for a total of $127.6''$. Divide $127.6''$ by $36''$ for a total of 3.54 yards. Round this number to 4 yards.

Cording

Provide 1 yard.

Total Amount of Fabric

Send a total of 5 yards.

CHAISE CUSHION

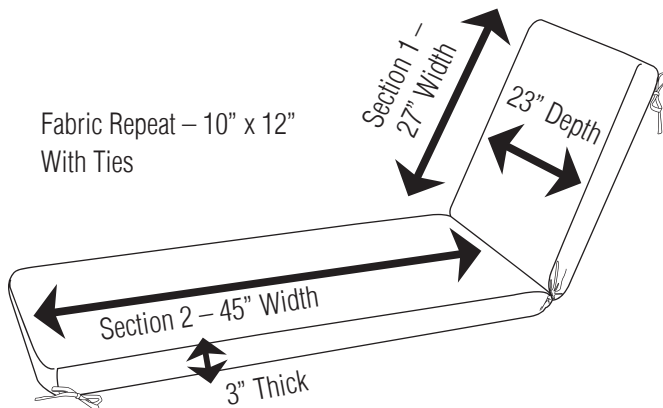

Fabric Repeat – 10" x 12"
With Ties

Length

72" (27" + 45", longest side) + 6" (3" thickness x 2) + 6" (1 break x 3" thickness x 2) + 2" (ties) = 86" Length

Depth

23" (short side) + 3" (thickness) = 26" Depth
Since 26" is greater than 25", double its length to 172" (adjusted length).

Fabric Repeat

10" + 12" equals 22", thus you will multiply your adjusted length by 1.2 for a total of 206.4". Divide 206.4" by 36" for a total of 5.73 yards. Round this number to 6 yards.

Cording

Provide 1 yard.

Total Amount of Fabric

Send a total of 7 yards.

DOUBLE CHAISE CUSHION

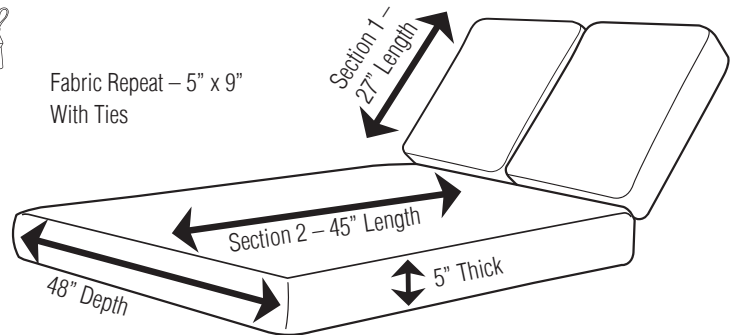

Fabric Repeat – 5" x 9"
With Ties

Length

72" (27" + 45", longest side) + 10" (5" thickness x 2) + 10" (1 break x 5" thickness x 2) + 2" (ties) = 94" Length

Depth

48" (short side) + 5" (thickness) = 53" Depth
Since 53" is greater than 52", multiply its length by 2.6 to equal 244.4" (adjusted length).

Fabric Repeat

5" + 9" equals 14", thus you will multiply your adjusted width by 1.1 for a total of 268.8". Divide 268.8" by 36" for a total of 7.47 yards. Round this number to 8 yards.

Cording

Provide 1 yard.

Total Amount of Fabric

Send a total of 9 yards.

DEEP SEATING SOFA

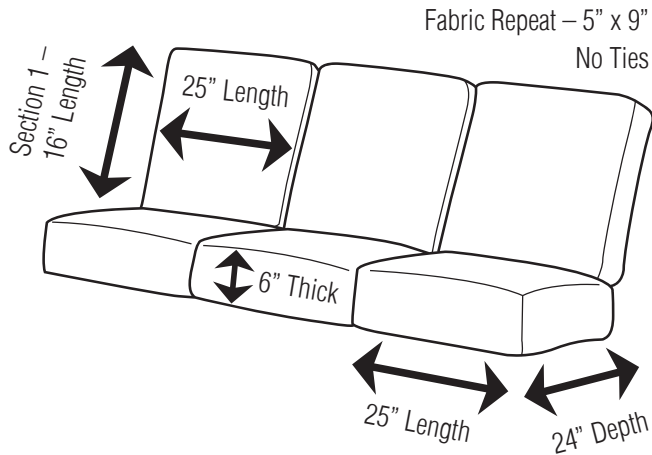

Length

25" (longest side) + 12" (6" thickness x 2) = 37" Length

Depth

24" (short side) + 6" (thickness) = 30" Depth

Since 30" is greater than 25", multiply its length by 2 to equal 74" (adjusted length).

Fabric Repeat

5" + 9" equals 14", thus you will multiply your adjusted length of 74" by 1.1 for a total of 81.4". Divide 81.4" by 36" for a total of 2.26 yards.

Multiply 2.26 yards by 3 cushions, equaling 6.78 yards.

Now multiply your adjusted length of 37" by 1.1 for a total of 40.7". Divide 40.7" by 36" for a total of 1.13 yards. Multiply 1.13 yards by 3 cushions, equals 3.39 yards. 6.78 + 3.39 = 10.17 yards. Round this number to 11 yards.

Cording

Provide 1 yard.

Total Amount of Fabric

Send a total of 12 yards.

Suggested Retail Labor for

Seat Cushions with Bio Comfort® Foam Fill

Zippers / Ties / Knife and Boxed Edges

PRICING

Depth		12"–13 1/2"							
Thickness (Measured in Inches)		2	3	4	5	6	7	8	
Width		KNIFE	KNIFE	BOXED	BOXED	BOXED	BOXED	BOXED	
0	to 12	\$57.95	\$63.17	\$69.42	\$75.12	\$77.97	\$80.82	\$83.67	
12	to 14	\$58.94	\$64.43	\$70.78	\$76.99	\$80.10	\$83.20	\$86.31	
14	to 16	\$59.94	\$65.68	\$72.15	\$78.87	\$82.23	\$85.59	\$88.96	
16	to 18	\$60.94	\$66.95	\$73.53	\$80.76	\$84.38	\$87.99	\$91.61	
18	to 20	\$61.94	\$68.22	\$74.91	\$82.65	\$86.52	\$90.40	\$94.27	
20	to 22	\$62.95	\$69.49	\$76.30	\$84.55	\$88.68	\$92.81	\$96.93	
22	to 24	\$63.97	\$70.77	\$77.69	\$86.46	\$90.84	\$95.22	\$99.61	
24	to 26	\$64.99	\$72.06	\$79.09	\$88.37	\$93.01	\$97.65	\$102.29	

Depth		14"–15 1/2"							
Thickness (Measured in Inches)		2	3	4	5	6	7	8	
Width		KNIFE	KNIFE	BOXED	BOXED	BOXED	BOXED	BOXED	
0	to 12	\$61.65	\$67.09	\$73.64	\$79.83	\$82.92	\$86.01	\$89.10	
12	to 14	\$62.75	\$68.50	\$75.16	\$81.94	\$85.32	\$88.71	\$92.10	
14	to 16	\$63.86	\$69.90	\$76.69	\$84.06	\$87.74	\$91.42	\$95.10	
16	to 18	\$64.97	\$71.31	\$78.23	\$86.18	\$90.16	\$94.14	\$98.11	
18	to 20	\$66.09	\$72.73	\$79.77	\$88.32	\$92.59	\$96.86	\$101.13	
20	to 22	\$67.21	\$74.16	\$81.32	\$90.45	\$95.02	\$99.59	\$104.16	
22	to 24	\$68.34	\$75.59	\$82.88	\$92.60	\$97.46	\$102.33	\$107.19	
24	to 26	\$69.47	\$77.03	\$84.44	\$94.75	\$99.91	\$105.07	\$110.23	

Bio Comfort® foam fill pricing applies to Standard and Premium Indoor fill styles. For up-to-date pricing, please visit www.DesignerCustomSource.com.

Suggested Retail Labor for

Seat Cushions with Bio Comfort® Foam Fill

Zippers / Ties / Knife and Boxed Edges

PRICING

Depth		16" - 17 1/2"							
Thickness (Measured in Inches)		2	3	3	4	5	6	7	8
Width		KNIFE	BOXED	KNIFE	BOXED	BOXED	BOXED	BOXED	BOXED
0	to 12	\$65.35	\$73.15	\$71.02	\$77.87	\$81.20	\$84.53	\$91.20	\$94.53
12	to 14	\$66.56	\$74.48	\$72.56	\$79.55	\$83.22	\$86.88	\$94.22	\$97.89
14	to 16	\$67.78	\$75.82	\$74.12	\$81.24	\$85.24	\$89.24	\$97.25	\$101.25
16	to 18	\$69.00	\$77.17	\$75.68	\$82.93	\$87.27	\$91.61	\$100.28	\$104.62
18	to 20	\$70.23	\$78.52	\$77.25	\$84.63	\$89.31	\$93.98	\$103.32	\$108.00
20	to 22	\$71.47	\$79.88	\$78.82	\$86.34	\$91.35	\$96.36	\$106.37	\$111.38
22	to 24	\$72.71	\$81.25	\$80.40	\$88.06	\$93.40	\$98.75	\$109.43	\$114.77
24	to 26	\$73.96	\$82.62	\$81.99	\$89.78	\$95.46	\$101.14	\$112.50	\$118.17

Depth		18" - 19 1/2"							
Thickness (Measured in Inches)		2	3	3	4	5	6	7	8
Width		KNIFE	BOXED	KNIFE	BOXED	BOXED	BOXED	BOXED	BOXED
0	to 12	\$69.04	\$77.13	\$74.94	\$82.09	\$85.66	\$89.24	\$96.39	\$99.96
12	to 14	\$70.37	\$78.58	\$76.63	\$83.93	\$87.88	\$91.83	\$99.72	\$103.67
14	to 16	\$71.70	\$80.04	\$78.34	\$85.78	\$90.10	\$94.42	\$103.07	\$107.39
16	to 18	\$73.03	\$81.51	\$80.05	\$87.63	\$92.33	\$97.03	\$106.43	\$111.12
18	to 20	\$74.37	\$82.98	\$81.76	\$89.50	\$94.57	\$99.64	\$109.79	\$114.86
20	to 22	\$75.72	\$84.46	\$83.49	\$91.37	\$96.81	\$102.26	\$113.16	\$118.60
22	to 24	\$77.08	\$85.95	\$85.22	\$93.25	\$99.07	\$104.89	\$116.53	\$122.36
24	to 26	\$78.44	\$87.45	\$86.95	\$95.13	\$101.33	\$107.53	\$119.92	\$126.12

Bio Comfort® foam fill pricing applies to Standard and Premium Indoor fill styles. For up-to-date pricing, please visit www.DesignerCustomSource.com.

Suggested Retail Labor for

Seat Cushions with Bio Comfort® Foam Fill

Zippers / Ties / Knife and Boxed Edges

PRICING

Depth		20"–21 1/2"								
Thickness (Measured in Inches)		2	2	3	3	4	5	6	7	8
Width		KNIFE	BOXED	KNIFE	BOXED	BOXED	BOXED	BOXED	BOXED	BOXED
0	to 12	\$72.74	\$81.11	\$78.86	\$86.31	\$90.13	\$93.94	\$97.76	\$101.57	\$105.39
12	to 14	\$74.18	\$82.68	\$80.70	\$88.31	\$92.54	\$96.77	\$101.00	\$105.23	\$109.46
14	to 16	\$75.62	\$84.26	\$82.56	\$90.32	\$94.96	\$99.61	\$104.25	\$108.90	\$113.54
16	to 18	\$77.06	\$85.85	\$84.41	\$92.34	\$97.40	\$102.45	\$107.51	\$112.57	\$117.63
18	to 20	\$78.52	\$87.44	\$86.28	\$94.36	\$99.83	\$105.31	\$110.78	\$116.25	\$121.72
20	to 22	\$79.98	\$89.05	\$88.15	\$96.39	\$102.28	\$108.17	\$114.05	\$119.94	\$125.83
22	to 24	\$81.45	\$90.66	\$90.03	\$98.43	\$104.73	\$111.03	\$117.34	\$123.64	\$129.94
24	to 26	\$82.92	\$92.27	\$91.92	\$100.48	\$107.19	\$113.91	\$120.63	\$127.34	\$134.06

Depth		22"–23 1/2"								
Thickness (Measured in Inches)		2	2	3	3	4	5	6	7	8
Width		KNIFE	BOXED	KNIFE	BOXED	BOXED	BOXED	BOXED	BOXED	BOXED
0	to 12	\$76.44	\$85.09	\$82.78	\$90.54	\$94.59	\$98.65	\$102.71	\$106.76	\$110.82
12	to 14	\$77.98	\$86.78	\$84.77	\$92.70	\$97.21	\$101.72	\$106.23	\$110.74	\$115.25
14	to 16	\$79.54	\$88.48	\$86.77	\$94.86	\$99.83	\$104.79	\$109.76	\$114.72	\$119.69
16	to 18	\$81.10	\$90.19	\$88.78	\$97.04	\$102.46	\$107.88	\$113.30	\$118.71	\$124.13
18	to 20	\$82.66	\$91.91	\$90.80	\$99.22	\$105.10	\$110.97	\$116.84	\$122.71	\$128.59
20	to 22	\$84.24	\$93.63	\$92.82	\$101.42	\$107.74	\$114.07	\$120.40	\$126.72	\$133.05
22	to 24	\$85.82	\$95.36	\$94.85	\$103.62	\$110.40	\$117.18	\$123.96	\$130.74	\$137.52
24	to 26	\$87.40	\$97.10	\$96.88	\$105.82	\$113.06	\$120.30	\$127.53	\$134.77	\$142.01

Bio Comfort® foam fill pricing applies to Standard and Premium Indoor fill styles. For up-to-date pricing, please visit www.DesignerCustomSource.com.

Suggested Retail Labor for

Seat Cushions with Bio Comfort® Foam Fill

Zippers / Ties / Knife and Boxed Edges

PRICING

Depth		24" - 25 1/2"							
Thickness (Measured in Inches)		2	3	4	5	6	7	8	
Width		KNIFE	KNIFE	BOXED	BOXED	BOXED	BOXED	BOXED	
0	to 12	\$80.14	\$86.70	\$94.76	\$99.06	\$103.35	\$107.65	\$111.95	
12	to 14	\$81.79	\$88.84	\$97.08	\$101.87	\$106.66	\$111.45	\$116.24	
14	to 16	\$83.46	\$90.99	\$99.41	\$104.69	\$109.98	\$115.26	\$120.55	
16	to 18	\$85.13	\$93.15	\$101.74	\$107.52	\$113.30	\$119.08	\$124.86	
18	to 20	\$86.81	\$95.31	\$104.09	\$110.36	\$116.63	\$122.91	\$129.18	
20	to 22	\$88.49	\$97.48	\$106.44	\$113.21	\$119.97	\$126.74	\$133.51	
22	to 24	\$90.19	\$99.66	\$108.80	\$116.06	\$123.32	\$130.58	\$137.85	
24	to 26	\$91.89	\$101.85	\$111.17	\$118.93	\$126.68	\$134.44	\$142.19	

Depth		26"							
Thickness (Measured in Inches)		2	3	4	5	6	7	8	
Width		KNIFE	KNIFE	BOXED	BOXED	BOXED	BOXED	BOXED	
0	to 12	\$83.83	\$90.62	\$98.98	\$103.52	\$108.06	\$112.60	\$117.14	
12	to 14	\$85.60	\$92.91	\$101.46	\$106.53	\$111.61	\$116.68	\$121.75	
14	to 16	\$87.38	\$95.21	\$103.95	\$109.55	\$115.16	\$120.77	\$126.37	
16	to 18	\$89.16	\$97.51	\$106.44	\$112.58	\$118.72	\$124.86	\$131.00	
18	to 20	\$90.95	\$99.83	\$108.95	\$115.62	\$122.30	\$128.97	\$135.64	
20	to 22	\$92.75	\$102.15	\$111.46	\$118.67	\$125.88	\$133.08	\$140.29	
22	to 24	\$94.55	\$104.48	\$113.99	\$121.73	\$129.47	\$137.21	\$144.95	
24	to 26	\$96.37	\$106.81	\$116.52	\$124.79	\$133.07	\$141.34	\$149.62	

Bio Comfort® foam fill pricing applies to Standard and Premium Indoor fill styles. For up-to-date pricing, please visit www.DesignerCustomSource.com.

Suggested Retail Labor for

Seat Cushions with Bio Comfort® Foam Fill

Zippers / Ties / Single Cording / Double Cording

PRICING

Depth		12"–13 1/2"								
Thickness (Measured in Inches)		2	2	3	3	4	5	6	7	8
Width		SGL CRD	DBL CRD	SGL CRD	DBL CRD	SGL CRD	DBL CRD	SGL CRD	DBL CRD	DBL CRD
0	to 12	\$61.87	\$71.20	\$67.09	\$75.44	\$78.29	\$81.14	\$83.99	\$86.84	\$89.69
12	to 14	\$63.39	\$73.41	\$68.88	\$77.92	\$81.02	\$84.13	\$87.23	\$90.34	\$93.44
14	to 16	\$64.91	\$75.62	\$70.66	\$80.40	\$83.76	\$87.12	\$90.48	\$93.84	\$97.20
16	to 18	\$66.44	\$77.84	\$72.45	\$82.89	\$86.50	\$90.12	\$93.74	\$97.35	\$100.97
18	to 20	\$67.98	\$80.07	\$74.25	\$85.38	\$89.25	\$93.13	\$97.00	\$100.87	\$104.74
20	to 22	\$69.52	\$82.30	\$76.06	\$87.88	\$92.01	\$96.14	\$100.27	\$104.39	\$108.52
22	to 24	\$71.06	\$84.53	\$77.87	\$90.39	\$94.77	\$99.16	\$103.54	\$107.92	\$112.31
24	to 26	\$72.61	\$86.78	\$79.68	\$92.90	\$97.54	\$102.18	\$106.82	\$111.46	\$116.10

Depth		14"–15 1/2"								
Thickness (Measured in Inches)		2	2	3	3	4	5	6	7	8
Width		SGL CRD	DBL CRD	SGL CRD	DBL CRD	SGL CRD	DBL CRD	SGL CRD	DBL CRD	DBL CRD
0	to 12	\$66.10	\$78.75	\$71.54	\$83.23	\$86.32	\$89.41	\$92.50	\$95.59	\$98.69
12	to 14	\$67.73	\$81.10	\$73.47	\$85.89	\$89.27	\$92.66	\$96.05	\$99.43	\$102.82
14	to 16	\$69.36	\$83.46	\$75.41	\$88.55	\$92.24	\$95.92	\$99.60	\$103.28	\$106.96
16	to 18	\$71.00	\$85.82	\$77.35	\$91.23	\$95.21	\$99.18	\$103.16	\$107.14	\$111.11
18	to 20	\$72.65	\$88.19	\$79.30	\$93.91	\$98.18	\$102.45	\$106.72	\$111.00	\$115.27
20	to 22	\$74.30	\$90.57	\$81.25	\$96.60	\$101.16	\$105.73	\$110.30	\$114.87	\$119.43
22	to 24	\$75.96	\$92.95	\$83.21	\$99.29	\$104.15	\$109.02	\$113.88	\$118.74	\$123.60
24	to 26	\$77.62	\$95.34	\$85.17	\$101.99	\$107.15	\$112.31	\$117.47	\$122.62	\$127.78

Bio Comfort® foam fill pricing applies to Standard and Premium Indoor fill styles. For up-to-date pricing, please visit www.DesignerCustomSource.com.

Suggested Retail Labor for

Seat Cushions with Bio Comfort[®] Foam Fill

Zippers / Ties / Single Cording / Double Cording

PRICING

Depth		16"–17 1/2"								
Thickness (Measured in Inches)		2	2	3	3	4	5	6	7	8
Width		SGL CRD	DBL CRD	SGL CRD	DBL CRD	SGL CRD	DBL CRD	SGL CRD	DBL CRD	DBL CRD
0	to 12	\$70.32	\$83.87	\$75.99	\$88.59	\$91.92	\$95.25	\$98.59	\$101.92	\$105.25
12	to 14	\$72.07	\$86.34	\$78.07	\$91.41	\$95.08	\$98.74	\$102.41	\$106.08	\$109.75
14	to 16	\$73.81	\$88.82	\$80.16	\$94.24	\$98.24	\$102.24	\$106.24	\$110.24	\$114.25
16	to 18	\$75.56	\$91.30	\$82.25	\$97.07	\$101.41	\$105.74	\$110.08	\$114.42	\$118.76
18	to 20	\$77.32	\$93.79	\$84.34	\$99.91	\$104.58	\$109.25	\$113.93	\$118.60	\$123.27
20	to 22	\$79.09	\$96.29	\$86.44	\$102.76	\$107.77	\$112.77	\$117.78	\$122.79	\$127.79
22	to 24	\$80.86	\$98.80	\$88.55	\$105.61	\$110.96	\$116.30	\$121.64	\$126.98	\$132.33
24	to 26	\$82.63	\$101.31	\$90.67	\$108.47	\$114.15	\$119.83	\$125.51	\$131.19	\$136.87

Depth		18"–19 1/2"								
Thickness (Measured in Inches)		2	2	3	3	4	5	6	7	8
Width		SGL CRD	DBL CRD	SGL CRD	DBL CRD	SGL CRD	DBL CRD	SGL CRD	DBL CRD	DBL CRD
0	to 12	\$74.55	\$88.99	\$80.44	\$93.95	\$97.52	\$101.10	\$104.67	\$108.25	\$111.82
12	to 14	\$76.40	\$91.58	\$82.67	\$96.93	\$100.88	\$104.83	\$108.78	\$112.72	\$116.67
14	to 16	\$78.26	\$94.18	\$84.90	\$99.92	\$104.24	\$108.56	\$112.89	\$117.21	\$121.53
16	to 18	\$80.12	\$96.78	\$87.14	\$102.91	\$107.61	\$112.31	\$117.00	\$121.70	\$126.40
18	to 20	\$82.00	\$99.40	\$89.39	\$105.91	\$110.98	\$116.06	\$121.13	\$126.20	\$131.27
20	to 22	\$83.87	\$102.02	\$91.64	\$108.92	\$114.37	\$119.81	\$125.26	\$130.71	\$136.16
22	to 24	\$85.76	\$104.64	\$93.90	\$111.94	\$117.76	\$123.58	\$129.40	\$135.23	\$141.05
24	to 26	\$87.64	\$107.27	\$96.16	\$114.96	\$121.16	\$127.35	\$133.55	\$139.75	\$145.95

Bio Comfort[®] foam fill pricing applies to Standard and Premium Indoor fill styles. For up-to-date pricing, please visit www.DesignerCustomSource.com.

Suggested Retail Labor for

Seat Cushions with Bio Comfort® Foam Fill

Zippers / Ties / Single Cording / Double Cording

PRICING

Depth		20"–21 1/2"							
Thickness (Measured in Inches)		2	3	4	5	6	7	8	
Width		SGL CRD	DBL CRD	SGL CRD	DBL CRD	SGL CRD	DBL CRD	SGL CRD	DBL CRD
0	to 12	\$78.78	\$94.11	\$84.89	\$99.31	\$103.13	\$106.94	\$110.76	\$114.57
12	to 14	\$80.74	\$96.82	\$87.27	\$102.45	\$106.68	\$110.91	\$115.14	\$119.37
14	to 16	\$82.71	\$99.54	\$89.65	\$105.60	\$110.24	\$114.88	\$119.53	\$124.17
16	to 18	\$84.69	\$102.26	\$92.04	\$108.75	\$113.81	\$118.87	\$123.93	\$128.98
18	to 20	\$86.67	\$105.00	\$94.43	\$111.91	\$117.39	\$122.86	\$128.33	\$133.80
20	to 22	\$88.66	\$107.74	\$96.83	\$115.08	\$120.97	\$126.86	\$132.74	\$138.63
22	to 24	\$90.65	\$110.49	\$99.24	\$118.26	\$124.56	\$130.86	\$137.17	\$143.47
24	to 26	\$92.66	\$113.24	\$101.65	\$121.44	\$128.16	\$134.88	\$141.60	\$148.31

Depth		22"–23 1/2"							
Thickness (Measured in Inches)		2	3	4	5	6	7	8	
Width		SGL CRD	DBL CRD	SGL CRD	DBL CRD	SGL CRD	DBL CRD	SGL CRD	DBL CRD
0	to 12	\$83.00	\$99.23	\$89.35	\$104.67	\$108.73	\$112.79	\$116.84	\$120.90
12	to 14	\$85.08	\$102.06	\$91.87	\$107.97	\$112.48	\$116.99	\$121.50	\$126.01
14	to 16	\$87.16	\$104.90	\$94.40	\$111.28	\$116.24	\$121.21	\$126.17	\$131.14
16	to 18	\$89.25	\$107.74	\$96.93	\$114.59	\$120.01	\$125.43	\$130.85	\$136.27
18	to 20	\$91.34	\$110.60	\$99.47	\$117.91	\$123.79	\$129.66	\$135.53	\$141.41
20	to 22	\$93.44	\$113.46	\$102.02	\$121.24	\$127.57	\$133.90	\$140.23	\$146.55
22	to 24	\$95.55	\$116.33	\$104.58	\$124.58	\$131.36	\$138.15	\$144.93	\$151.71
24	to 26	\$97.67	\$119.21	\$107.15	\$127.93	\$135.17	\$142.40	\$149.64	\$156.87

Bio Comfort® foam fill pricing applies to Standard and Premium Indoor fill styles. For up-to-date pricing, please visit www.DesignerCustomSource.com.

Suggested Retail Labor for

Seat Cushions with Bio Comfort® Foam Fill

Zippers / Ties / Single Cording / Double Cording

PRICING

Depth		24" - 25 1/2"								
Thickness (Measured in Inches)		2	3	4	5	6	7	8		
Width		SGL CRD	DBL CRD	SGL CRD	DBL CRD	SGL CRD	DBL CRD	SGL CRD	DBL CRD	
0	to 12	\$87.23	\$104.35	\$93.80	\$110.03	\$114.33	\$118.63	\$122.93	\$127.23	\$131.52
12	to 14	\$89.41	\$107.30	\$96.46	\$113.49	\$118.28	\$123.08	\$127.87	\$132.66	\$137.45
14	to 16	\$91.61	\$110.26	\$99.14	\$116.96	\$122.24	\$127.53	\$132.81	\$138.10	\$143.38
16	to 18	\$93.81	\$113.23	\$101.83	\$120.43	\$126.21	\$131.99	\$137.77	\$143.55	\$149.33
18	to 20	\$96.01	\$116.20	\$104.52	\$123.92	\$130.19	\$136.46	\$142.73	\$149.01	\$155.28
20	to 22	\$98.23	\$119.18	\$107.22	\$127.41	\$134.17	\$140.94	\$147.71	\$154.48	\$161.24
22	to 24	\$100.45	\$122.17	\$109.93	\$130.91	\$138.17	\$145.43	\$152.69	\$159.95	\$167.21
24	to 26	\$102.68	\$125.17	\$112.64	\$134.41	\$142.17	\$149.93	\$157.68	\$165.44	\$173.19

Depth		26"								
Thickness (Measured in Inches)		2	3	4	5	6	7	8		
Width		SGL CRD	DBL CRD	SGL CRD	DBL CRD	SGL CRD	DBL CRD	SGL CRD	DBL CRD	
0	to 12	\$91.46	\$109.47	\$98.25	\$115.40	\$119.94	\$124.47	\$129.01	\$133.55	\$138.09
12	to 14	\$93.75	\$112.54	\$101.06	\$119.01	\$124.09	\$129.16	\$134.23	\$139.30	\$144.38
14	to 16	\$96.06	\$115.62	\$103.89	\$122.64	\$128.25	\$133.85	\$139.46	\$145.06	\$150.67
16	to 18	\$98.37	\$118.71	\$106.72	\$126.27	\$132.41	\$138.55	\$144.69	\$150.83	\$156.97
18	to 20	\$100.69	\$121.80	\$109.56	\$129.92	\$136.59	\$143.26	\$149.94	\$156.61	\$163.28
20	to 22	\$103.01	\$124.90	\$112.41	\$133.57	\$140.78	\$147.98	\$155.19	\$162.40	\$169.60
22	to 24	\$105.35	\$128.02	\$115.27	\$137.23	\$144.97	\$152.71	\$160.45	\$168.19	\$175.94
24	to 26	\$107.69	\$131.14	\$118.13	\$140.90	\$149.17	\$157.45	\$165.72	\$174.00	\$182.28

Bio Comfort® foam fill pricing applies to Standard and Premium Indoor fill styles. For up-to-date pricing, please visit www.DesignerCustomSource.com.

Suggested Retail Labor for

Seat Cushions with CumuPlush Fill

Zippers / Ties / Knife and Boxed Edges

PRICING

Depth		12" – 13 1/2"							
Thickness (Measured in Inches)		2	3	4	5	6	7	8	
Width		KNIFE	KNIFE	BOXED	BOXED	BOXED	BOXED	BOXED	
0	to 12	\$57.45	\$62.06	\$68.22	\$70.41	\$72.60	\$74.79	\$79.18	
12	to 14	\$58.35	\$63.12	\$69.38	\$71.72	\$74.05	\$76.39	\$81.07	
14	to 16	\$59.26	\$64.20	\$70.55	\$73.03	\$75.51	\$78.00	\$82.96	
16	to 18	\$60.18	\$65.27	\$71.72	\$74.35	\$76.98	\$79.61	\$84.87	
18	to 20	\$61.10	\$66.36	\$72.90	\$75.68	\$78.45	\$81.23	\$86.78	
20	to 22	\$62.03	\$67.45	\$74.09	\$77.01	\$79.93	\$82.85	\$88.69	
22	to 24	\$62.96	\$68.54	\$75.29	\$78.35	\$81.42	\$84.49	\$90.62	
24	to 26	\$63.90	\$69.64	\$76.49	\$79.70	\$82.91	\$86.12	\$92.55	

Depth		14" – 15 1/2"							
Thickness (Measured in Inches)		2	3	4	5	6	7	8	
Width		KE	KE	BOXED	BOXED	BOXED	BOXED	BOXED	
0	to 12	\$61.06	\$65.79	\$72.24	\$74.56	\$76.89	\$79.21	\$83.86	
12	to 14	\$62.06	\$66.98	\$73.53	\$76.02	\$78.51	\$81.00	\$85.98	
14	to 16	\$63.07	\$68.17	\$74.82	\$77.48	\$80.14	\$82.80	\$88.11	
16	to 18	\$64.08	\$69.36	\$76.13	\$78.95	\$81.77	\$84.60	\$90.25	
18	to 20	\$65.10	\$70.56	\$77.43	\$80.43	\$83.42	\$86.41	\$92.39	
20	to 22	\$66.13	\$71.77	\$78.75	\$81.91	\$85.07	\$88.23	\$94.54	
22	to 24	\$67.16	\$72.98	\$80.07	\$83.40	\$86.72	\$90.05	\$96.70	
24	to 26	\$68.20	\$74.20	\$81.40	\$84.89	\$88.39	\$91.88	\$98.87	

CumuPlush fill pricing applies to Standard Outdoor, Direct Fill and Plush fill styles. For up-to-date pricing, please visit www.DesignerCustomSource.com.

Suggested Retail Labor for

Seat Cushions with CumuPlush Fill

Zippers / Ties / Knife and Boxed Edges

PRICING

Depth		16" – 17 1/2"							
Thickness (Measured in Inches)		2	3	4	5	6	7	8	
Width		KNIFE	KNIFE	BOXED	BOXED	BOXED	BOXED	BOXED	
0	to 12	\$64.67	\$69.53	\$76.26	\$81.17	\$83.63	\$86.08	\$88.54	
12	to 14	\$65.77	\$70.83	\$77.68	\$82.96	\$85.61	\$88.25	\$90.89	
14	to 16	\$66.88	\$72.14	\$79.10	\$84.76	\$87.59	\$90.43	\$93.26	
16	to 18	\$67.99	\$73.45	\$80.53	\$86.57	\$89.59	\$92.61	\$95.63	
18	to 20	\$69.11	\$74.77	\$81.96	\$88.38	\$91.59	\$94.80	\$98.01	
20	to 22	\$70.23	\$76.09	\$83.40	\$90.20	\$93.60	\$97.00	\$100.40	
22	to 24	\$71.36	\$77.43	\$84.85	\$92.03	\$95.62	\$99.20	\$102.79	
24	to 26	\$72.50	\$78.76	\$86.31	\$93.86	\$97.64	\$101.42	\$105.19	

Depth		18" – 19 1/2"							
Thickness (Measured in Inches)		2	3	4	5	6	7	8	
Width		KNIFE	KNIFE	BOXED	BOXED	BOXED	BOXED	BOXED	
0	to 12	\$68.29	\$73.26	\$80.29	\$85.46	\$88.05	\$90.63	\$93.22	
12	to 14	\$69.48	\$74.68	\$81.83	\$87.42	\$90.22	\$93.01	\$95.81	
14	to 16	\$70.69	\$76.11	\$83.37	\$89.39	\$92.39	\$95.40	\$98.41	
16	to 18	\$71.90	\$77.54	\$84.93	\$91.36	\$94.58	\$97.79	\$101.01	
18	to 20	\$73.11	\$78.97	\$86.49	\$93.34	\$96.77	\$100.20	\$103.62	
20	to 22	\$74.33	\$80.42	\$88.06	\$95.34	\$98.97	\$102.61	\$106.25	
22	to 24	\$75.56	\$81.87	\$89.64	\$97.33	\$101.18	\$105.03	\$108.88	
24	to 26	\$76.80	\$83.33	\$91.22	\$99.34	\$103.40	\$107.45	\$111.51	

CumuPlush fill pricing applies to Standard Outdoor, Direct Fill and Plush fill styles. For up-to-date pricing, please visit www.DesignerCustomSource.com.

Suggested Retail Labor for

Seat Cushions with CumuPlush Fill

Zippers / Ties / Knife and Boxed Edges

PRICING

Depth		20"–21 1/2"							
Thickness (Measured in Inches)		2	3	4	5	6	7	8	
Width		KNIFE	KNIFE	BOXED	BOXED	BOXED	BOXED	BOXED	
0	to 12	\$71.90	\$77.00	\$84.31	\$89.74	\$92.46	\$95.18	\$97.90	
12	to 14	\$73.19	\$78.53	\$88.92	\$91.87	\$94.82	\$97.77	\$100.72	
14	to 16	\$74.49	\$80.08	\$90.83	\$94.01	\$97.19	\$100.37	\$103.55	
16	to 18	\$75.80	\$81.62	\$92.74	\$96.16	\$99.57	\$102.98	\$106.39	
18	to 20	\$77.12	\$83.18	\$94.66	\$98.31	\$101.95	\$105.60	\$109.24	
20	to 22	\$78.44	\$84.74	\$96.59	\$100.47	\$104.34	\$108.22	\$112.10	
22	to 24	\$79.76	\$86.31	\$98.53	\$102.64	\$106.75	\$110.85	\$114.96	
24	to 26	\$81.10	\$87.89	\$100.47	\$104.81	\$109.15	\$113.49	\$117.83	

Depth		22"–23 1/2"							
Thickness (Measured in Inches)		2	3	4	5	6	7	8	
Width		KNIFE	KNIFE	BOXED	BOXED	BOXED	BOXED	BOXED	
0	to 12	\$75.51	\$80.73	\$88.33	\$94.03	\$96.88	\$99.73	\$102.58	
12	to 14	\$76.90	\$82.39	\$90.12	\$96.33	\$99.43	\$102.53	\$105.64	
14	to 16	\$78.30	\$84.05	\$91.92	\$98.64	\$101.99	\$105.35	\$108.70	
16	to 18	\$79.71	\$85.71	\$93.73	\$100.95	\$104.56	\$108.17	\$111.77	
18	to 20	\$81.12	\$87.38	\$95.55	\$103.27	\$107.13	\$110.99	\$114.86	
20	to 22	\$82.54	\$89.07	\$101.49	\$105.60	\$109.72	\$113.83	\$117.95	
22	to 24	\$83.96	\$90.75	\$103.57	\$107.94	\$112.31	\$116.68	\$121.05	
24	to 26	\$85.40	\$92.45	\$105.67	\$110.29	\$114.91	\$119.53	\$124.16	

CumuPlush fill pricing applies to Standard Outdoor, Direct Fill and Plush fill styles. For up-to-date pricing, please visit www.DesignerCustomSource.com.

Suggested Retail Labor for

Seat Cushions with CumuPlush Fill

Zippers / Ties / Knife and Boxed Edges

PRICING

Depth		24" - 25 1/2"							
Thickness (Measured in Inches)		2	3	4	5	6	7	8	
Width		KNIFE	KNIFE	BOXED	BOXED	BOXED	BOXED	BOXED	
0	to 12	\$79.13	\$84.47	\$92.35	\$95.34	\$98.32	\$101.30	\$104.28	
12	to 14	\$80.61	\$86.24	\$94.27	\$97.53	\$100.78	\$104.04	\$107.29	
14	to 16	\$82.11	\$88.02	\$96.20	\$99.73	\$103.26	\$106.79	\$110.32	
16	to 18	\$83.61	\$89.80	\$98.14	\$101.94	\$105.74	\$109.55	\$113.35	
18	to 20	\$85.12	\$91.59	\$100.08	\$104.16	\$108.24	\$112.31	\$116.39	
20	to 22	\$86.64	\$93.39	\$102.03	\$106.38	\$110.74	\$115.09	\$119.44	
22	to 24	\$88.16	\$95.20	\$103.99	\$108.62	\$113.25	\$117.88	\$122.50	
24	to 26	\$89.70	\$97.01	\$105.96	\$110.86	\$115.77	\$120.67	\$125.57	

Depth		26"							
Thickness (Measured in Inches)		2	3	4	5	6	7	8	
Width		KNIFE	KNIFE	BOXED	BOXED	BOXED	BOXED	BOXED	
0	to 12	\$82.74	\$88.21	\$96.38	\$99.49	\$102.60	\$105.72	\$108.83	
12	to 14	\$84.33	\$90.09	\$98.42	\$101.83	\$105.24	\$108.65	\$112.06	
14	to 16	\$85.92	\$91.98	\$100.48	\$104.18	\$107.88	\$111.59	\$115.29	
16	to 18	\$87.52	\$93.89	\$102.54	\$106.54	\$110.54	\$114.54	\$118.54	
18	to 20	\$89.13	\$95.80	\$104.61	\$108.90	\$113.20	\$117.50	\$121.79	
20	to 22	\$90.74	\$97.71	\$106.69	\$111.28	\$115.87	\$120.46	\$125.06	
22	to 24	\$92.37	\$99.64	\$108.77	\$113.66	\$118.55	\$123.44	\$128.33	
24	to 26	\$94.00	\$101.57	\$110.87	\$116.06	\$121.24	\$126.43	\$131.61	

CumuPlush fill pricing applies to Standard Outdoor, Direct Fill and Plush fill styles. For up-to-date pricing, please visit www.DesignerCustomSource.com.

Suggested Retail Labor for

Seat Cushions with CumuPlush Fill

Zippers / Ties / Single Cording / Double Cording

PRICING

Depth		12"–13 1/2"									
Thickness (Measured in Inches)		2	2	3	3	4	5	6	7	8	
Width		SGL CRD	DBL CRD	SGL CRD	DBL CRD	SGL CRD	DBL CRD	SGL CRD	DBL CRD	SGL CRD	DBL CRD
0	to 12	\$60.02	\$67.76	\$64.63	\$71.34	\$73.53	\$75.72	\$77.91	\$80.11	\$82.30	
12	to 14	\$61.35	\$69.65	\$66.12	\$73.39	\$75.73	\$78.07	\$80.40	\$82.74	\$85.08	
14	to 16	\$62.69	\$71.55	\$67.62	\$75.45	\$77.93	\$80.42	\$82.90	\$85.38	\$87.87	
16	to 18	\$64.03	\$73.46	\$69.12	\$77.52	\$80.14	\$82.77	\$85.40	\$88.03	\$90.66	
18	to 20	\$65.38	\$75.37	\$70.63	\$79.59	\$82.36	\$85.14	\$87.91	\$90.69	\$93.46	
20	to 22	\$66.73	\$77.29	\$72.15	\$81.66	\$84.58	\$87.51	\$90.43	\$93.35	\$96.27	
22	to 24	\$68.08	\$79.21	\$73.67	\$83.75	\$86.81	\$89.88	\$92.95	\$96.01	\$99.08	
24	to 26	\$69.45	\$81.14	\$75.19	\$85.84	\$89.05	\$92.26	\$95.48	\$98.69	\$101.90	

Depth		14"–15 1/2"									
Thickness (Measured in Inches)		2	2	3	3	4	5	6	7	8	
Width		SGL CRD	DBL CRD	SGL CRD	DBL CRD	SGL CRD	DBL CRD	SGL CRD	DBL CRD	SGL CRD	DBL CRD
0	to 12	\$64.06	\$74.99	\$68.79	\$78.70	\$81.03	\$83.35	\$85.67	\$88.00	\$90.32	
12	to 14	\$65.49	\$77.01	\$70.40	\$80.91	\$83.40	\$85.89	\$88.38	\$90.87	\$93.36	
14	to 16	\$66.92	\$79.04	\$72.02	\$83.12	\$85.77	\$88.43	\$91.09	\$93.75	\$96.40	
16	to 18	\$68.36	\$81.08	\$73.64	\$85.33	\$88.16	\$90.98	\$93.81	\$96.63	\$99.46	
18	to 20	\$69.80	\$83.12	\$75.26	\$87.56	\$90.55	\$93.54	\$96.53	\$99.52	\$102.52	
20	to 22	\$71.25	\$85.17	\$76.90	\$89.79	\$92.95	\$96.11	\$99.26	\$102.42	\$105.58	
22	to 24	\$72.71	\$87.22	\$78.53	\$92.02	\$95.35	\$98.68	\$102.00	\$105.33	\$108.66	
24	to 26	\$74.17	\$89.29	\$80.18	\$94.27	\$97.76	\$101.26	\$104.75	\$108.25	\$111.74	

CumuPlush fill pricing applies to Standard Outdoor, Direct Fill and Plush fill styles. For up-to-date pricing, please visit www.DesignerCustomSource.com.

Suggested Retail Labor for

Seat Cushions with CumuPlush Fill

Zippers / Ties / Single Cording / Double Cording

PRICING

Depth		16"–17 1/2"									
Thickness (Measured in Inches)		2	2	3	3	4	5	6	7	8	
Width		SGL CRD	DBL CRD	SGL CRD	DBL CRD	SGL CRD	DBL CRD	SGL CRD	DBL CRD	SGL CRD	DBL CRD
0	to 12	\$68.10	\$79.80	\$72.95	\$83.64	\$86.10	\$88.55	\$91.01	\$93.46	\$95.92	
12	to 14	\$69.62	\$81.93	\$74.68	\$85.97	\$88.61	\$91.26	\$93.90	\$96.54	\$99.19	
14	to 16	\$71.15	\$84.06	\$76.41	\$88.31	\$91.14	\$93.97	\$96.80	\$99.63	\$102.47	
16	to 18	\$72.69	\$86.20	\$78.15	\$90.65	\$93.67	\$96.69	\$99.71	\$102.73	\$105.75	
18	to 20	\$74.23	\$88.35	\$79.89	\$93.00	\$96.21	\$99.42	\$102.63	\$105.84	\$109.05	
20	to 22	\$75.78	\$90.50	\$81.64	\$95.36	\$98.76	\$102.15	\$105.55	\$108.95	\$112.35	
22	to 24	\$77.34	\$92.66	\$83.40	\$97.72	\$101.31	\$104.90	\$108.48	\$112.07	\$115.66	
24	to 26	\$78.90	\$94.83	\$85.16	\$100.09	\$103.87	\$107.65	\$111.42	\$115.20	\$118.98	

Depth		18"–19 1/2"									
Thickness (Measured in Inches)		2	2	3	3	4	5	6	7	8	
Width		SGL CRD	DBL CRD	SGL CRD	DBL CRD	SGL CRD	DBL CRD	SGL CRD	DBL CRD	SGL CRD	DBL CRD
0	to 12	\$72.14	\$84.60	\$77.11	\$88.58	\$91.16	\$93.75	\$96.34	\$98.93	\$101.51	
12	to 14	\$73.76	\$86.84	\$78.96	\$91.03	\$93.83	\$96.63	\$99.42	\$102.22	\$105.02	
14	to 16	\$75.39	\$89.08	\$80.81	\$93.50	\$96.50	\$99.51	\$102.52	\$105.52	\$108.53	
16	to 18	\$77.02	\$91.32	\$82.66	\$95.97	\$99.18	\$102.40	\$105.62	\$108.83	\$112.05	
18	to 20	\$78.66	\$93.58	\$84.52	\$98.45	\$101.87	\$105.30	\$108.73	\$112.15	\$115.58	
20	to 22	\$80.31	\$95.84	\$86.39	\$100.93	\$104.57	\$108.20	\$111.84	\$115.48	\$119.11	
22	to 24	\$81.96	\$98.10	\$88.27	\$103.42	\$107.27	\$111.12	\$114.96	\$118.81	\$122.66	
24	to 26	\$83.62	\$100.38	\$90.15	\$105.92	\$109.98	\$114.04	\$118.10	\$122.15	\$126.21	

CumuPlush fill pricing applies to Standard Outdoor, Direct Fill and Plush fill styles. For up-to-date pricing, please visit www.DesignerCustomSource.com.

Suggested Retail Labor for

Seat Cushions with CumuPlush Fill

Zippers / Ties / Single Cording / Double Cording

PRICING

Depth		20"–21 1/2"							
Thickness (Measured in Inches)		2	3	4	5	6	7	8	
Width		SGL CRD	DBL CRD	SGL CRD	DBL CRD	SGL CRD	DBL CRD	SGL CRD	DBL CRD
0	to 12	\$76.17	\$89.41	\$81.27	\$93.52	\$96.23	\$98.95	\$101.67	\$104.39
12	to 14	\$77.89	\$91.75	\$83.23	\$96.10	\$99.05	\$102.00	\$104.95	\$107.90
14	to 16	\$79.62	\$94.09	\$85.20	\$98.69	\$101.87	\$105.05	\$108.23	\$111.41
16	to 18	\$81.35	\$96.44	\$87.17	\$101.28	\$104.70	\$108.11	\$111.52	\$114.93
18	to 20	\$83.09	\$98.80	\$89.15	\$103.89	\$107.53	\$111.18	\$114.82	\$118.47
20	to 22	\$84.84	\$101.17	\$91.14	\$106.50	\$110.38	\$114.25	\$118.13	\$122.00
22	to 24	\$86.59	\$103.54	\$93.14	\$109.12	\$113.23	\$117.34	\$121.45	\$125.55
24	to 26	\$88.35	\$105.92	\$95.14	\$111.75	\$116.09	\$120.43	\$124.77	\$129.11

Depth		22"–23 1/2"							
Thickness (Measured in Inches)		2	3	4	5	6	7	8	
Width		SGL CRD	DBL CRD	SGL CRD	DBL CRD	SGL CRD	DBL CRD	SGL CRD	DBL CRD
0	to 12	\$80.21	\$94.22	\$85.43	\$98.45	\$101.30	\$104.15	\$107.00	\$109.85
12	to 14	\$82.03	\$96.66	\$87.51	\$101.16	\$104.27	\$107.37	\$110.47	\$113.57
14	to 16	\$83.85	\$99.11	\$89.60	\$103.88	\$107.23	\$110.59	\$113.94	\$117.30
16	to 18	\$85.68	\$101.57	\$91.69	\$106.60	\$110.21	\$113.82	\$117.43	\$121.04
18	to 20	\$87.52	\$104.03	\$93.78	\$109.33	\$113.20	\$117.06	\$120.92	\$124.78
20	to 22	\$89.36	\$106.50	\$95.89	\$112.07	\$116.19	\$120.30	\$124.42	\$128.53
22	to 24	\$91.21	\$108.98	\$98.00	\$114.82	\$119.19	\$123.56	\$127.93	\$132.29
24	to 26	\$93.07	\$111.47	\$100.12	\$117.58	\$122.20	\$126.82	\$131.44	\$136.06

CumuPlush fill pricing applies to Standard Outdoor, Direct Fill and Plush fill styles. For up-to-date pricing, please visit www.DesignerCustomSource.com.

Suggested Retail Labor for

Seat Cushions with CumuPlush Fill

Zippers / Ties / Single Cording / Double Cording

PRICING

Depth		24" - 25 1/2"							
Thickness (Measured in Inches)		2	3	4	5	6	7	8	
Width		SGL CRD	DBL CRD	SGL CRD	DBL CRD	SGL CRD	DBL CRD	SGL CRD	DBL CRD
0	to 12	\$84.25	\$99.02	\$89.59	\$103.39	\$106.37	\$109.36	\$112.34	\$115.32
12	to 14	\$86.16	\$101.57	\$91.79	\$106.23	\$109.48	\$112.74	\$115.99	\$119.25
14	to 16	\$88.09	\$104.12	\$93.99	\$109.07	\$112.60	\$116.13	\$119.66	\$123.19
16	to 18	\$90.01	\$106.69	\$96.20	\$111.92	\$115.72	\$119.53	\$123.33	\$127.14
18	to 20	\$91.95	\$109.26	\$98.41	\$114.78	\$118.86	\$122.94	\$127.01	\$131.09
20	to 22	\$93.89	\$111.83	\$100.64	\$117.65	\$122.00	\$126.35	\$130.71	\$135.06
22	to 24	\$95.84	\$114.42	\$102.87	\$120.52	\$125.15	\$129.78	\$134.41	\$139.03
24	to 26	\$97.80	\$117.01	\$105.11	\$123.40	\$128.31	\$133.21	\$138.11	\$143.02

Depth		26"							
Thickness (Measured in Inches)		2	3	4	5	6	7	8	
Width		SGL CRD	DBL CRD	SGL CRD	DBL CRD	SGL CRD	DBL CRD	SGL CRD	DBL CRD
0	to 89.384	\$88.29	\$103.83	\$93.76	\$108.33	\$111.44	\$114.56	\$117.67	\$120.78
12	to 91.577	\$90.30	\$106.48	\$96.07	\$111.29	\$114.70	\$118.11	\$121.52	\$124.92
14	to 93.777	\$92.32	\$109.14	\$98.38	\$114.26	\$117.96	\$121.67	\$125.37	\$129.08
16	to 95.985	\$94.34	\$111.81	\$100.71	\$117.24	\$121.24	\$125.24	\$129.24	\$133.24
18	to 98.200	\$96.38	\$114.48	\$103.05	\$120.22	\$124.52	\$128.81	\$133.11	\$137.41
20	to 100.423	\$98.42	\$117.17	\$105.39	\$123.22	\$127.81	\$132.40	\$136.99	\$141.59
22	to 102.654	\$100.46	\$119.86	\$107.74	\$126.22	\$131.11	\$136.00	\$140.89	\$145.77
24	to 104.892	\$102.52	\$122.56	\$110.10	\$129.23	\$134.42	\$139.60	\$144.79	\$149.97

CumuPlush fill pricing applies to Standard Outdoor, Direct Fill and Plush fill styles. For up-to-date pricing, please visit www.DesignerCustomSource.com.

Suggested Retail Labor for

Bench Cushions with Bio Comfort® Foam Fill

Zippers / Ties / Knife and Boxed Edges

PRICING

Depth		17"–19 1/2"							
Thickness (Measured in Inches)		2	3	4	5	6	7	8	
Width		KNIFE	KNIFE	BOXED	BOXED	BOXED	BOXED	BOXED	
26	to 28	\$88.16	\$94.56	\$100.30	\$106.70	\$113.10	\$119.50	\$147.61	\$155.11
28	to 32	\$91.13	\$98.26	\$104.12	\$111.26	\$118.39	\$125.52	\$155.53	\$163.89
32	to 36	\$94.13	\$102.00	\$107.98	\$115.85	\$123.71	\$131.58	\$163.49	\$172.72
36	to 40	\$97.16	\$105.77	\$111.86	\$120.47	\$129.07	\$137.68	\$171.50	\$181.59
40	to 44	\$100.23	\$109.57	\$115.78	\$125.12	\$134.46	\$143.80	\$179.55	\$190.50
44	to 48	\$110.45	\$121.22	\$128.00	\$138.77	\$149.54	\$160.31	\$198.67	\$211.18
48	to 52	\$113.79	\$125.34	\$132.26	\$143.82	\$155.38	\$166.94	\$207.29	\$220.71
52	to 56	\$117.16	\$129.51	\$136.56	\$148.91	\$161.26	\$173.61	\$215.95	\$230.29
56	to 60	\$120.57	\$133.71	\$140.90	\$154.04	\$167.18	\$180.32	\$224.66	\$239.91
60	to 66	\$125.74	\$140.06	\$147.47	\$161.80	\$176.12	\$190.44	\$237.79	\$254.42
66	to 72	\$139.44	\$155.95	\$164.08	\$180.59	\$197.10	\$213.61	\$264.99	\$284.00
72	to 78	\$145.12	\$162.90	\$171.27	\$189.04	\$206.82	\$224.60	\$279.09	\$299.56
78	to 88	\$154.75	\$174.64	\$183.42	\$203.31	\$223.20	\$243.09	\$302.82	\$325.72
88	to 98	\$171.62	\$194.56	\$204.18	\$227.12	\$250.06	\$272.99	\$326.90	\$352.24
98	to 108	\$182.23	\$207.38	\$217.48	\$242.63	\$267.78	\$292.93	\$351.36	\$379.15
108	to 120	\$195.32	\$223.13	\$233.84	\$261.65	\$289.46	\$317.27	\$381.20	\$411.92

Bio Comfort® foam fill pricing applies to Standard and Premium Indoor fill styles. For up-to-date pricing, please visit www.DesignerCustomSource.com.

Suggested Retail Labor for

Bench Cushions with Bio Comfort® Foam Fill

Zippers / Ties / Knife and Boxed Edges

PRICING

Depth		20"–22 1/2"							
Thickness (Measured in Inches)		2	3	4	5	6	7	8	
Width		KNIFE	KNIFE	BOXED	BOXED	BOXED	BOXED	BOXED	
26	to	\$95.40	\$102.67	\$108.41	\$115.68	\$122.95	\$130.22	\$161.19	\$169.71
28	to	\$98.75	\$106.87	\$112.73	\$120.86	\$128.98	\$137.11	\$170.27	\$179.80
32	to	\$102.12	\$111.10	\$117.08	\$126.07	\$135.05	\$144.03	\$179.40	\$189.93
36	to	\$105.53	\$115.37	\$121.47	\$131.31	\$141.15	\$151.00	\$188.57	\$200.11
40	to	\$108.97	\$119.67	\$125.89	\$136.59	\$147.29	\$158.00	\$197.79	\$210.33
44	to	\$120.20	\$132.56	\$139.34	\$151.70	\$164.06	\$176.42	\$219.23	\$233.58
48	to	\$123.95	\$137.23	\$144.14	\$157.42	\$170.70	\$183.98	\$229.08	\$244.50
52	to	\$127.73	\$141.93	\$148.99	\$163.19	\$177.39	\$191.59	\$238.99	\$255.48
56	to	\$131.56	\$146.68	\$153.88	\$169.00	\$184.12	\$199.24	\$248.94	\$266.50
60	to	\$137.35	\$153.86	\$161.27	\$177.78	\$194.28	\$210.79	\$263.95	\$283.12
66	to	\$152.48	\$171.52	\$179.65	\$198.69	\$217.74	\$236.78	\$294.59	\$316.52
72	to	\$158.84	\$179.36	\$187.73	\$208.25	\$228.77	\$249.29	\$310.69	\$334.32
78	to	\$169.61	\$192.59	\$201.38	\$224.36	\$247.35	\$270.33	\$337.76	\$364.22
88	to	\$191.61	\$218.60	\$228.39	\$255.39	\$282.38	\$309.38	\$365.20	\$394.51
98	to	\$203.65	\$233.27	\$243.55	\$273.17	\$302.78	\$332.40	\$393.05	\$425.21
108	to	\$218.51	\$251.28	\$262.17	\$294.95	\$327.72	\$360.50	\$426.98	\$462.56

Bio Comfort® foam fill pricing applies to Standard and Premium Indoor fill styles. For up-to-date pricing, please visit www.DesignerCustomSource.com.

Suggested Retail Labor for

Bench Cushions with Bio Comfort® Foam Fill

Zippers / Ties / Knife and Boxed Edges

PRICING

Depth		23" - 25 1/2"							
Thickness (Measured in Inches)		2	3	4	5	6	7	8	
Width		KNIFE	KNIFE	BOXED	BOXED	BOXED	BOXED	BOXED	
26	to	\$102.64	\$110.78	\$116.53	\$124.66	\$132.80	\$140.94	\$174.77	\$184.31
28	to	\$106.36	\$115.48	\$121.34	\$130.46	\$139.57	\$148.69	\$185.02	\$195.71
32	to	\$110.11	\$120.21	\$126.19	\$136.29	\$146.39	\$156.49	\$195.31	\$207.15
36	to	\$113.89	\$124.98	\$131.07	\$142.15	\$153.24	\$164.32	\$205.64	\$218.64
40	to	\$117.71	\$129.78	\$136.00	\$148.06	\$160.13	\$172.19	\$216.02	\$230.17
44	to	\$129.95	\$143.90	\$150.68	\$164.63	\$178.58	\$192.53	\$239.78	\$255.98
48	to	\$134.11	\$149.11	\$156.03	\$171.03	\$186.03	\$201.03	\$250.87	\$268.29
52	to	\$138.31	\$154.36	\$161.42	\$177.47	\$193.52	\$209.58	\$262.02	\$280.67
56	to	\$142.55	\$159.65	\$166.85	\$183.96	\$201.06	\$218.17	\$273.23	\$293.09
60	to	\$148.97	\$167.66	\$175.07	\$193.76	\$212.44	\$231.13	\$290.12	\$311.82
66	to	\$165.51	\$187.09	\$195.22	\$216.80	\$238.38	\$259.96	\$324.19	\$349.04
72	to	\$172.55	\$195.82	\$204.19	\$227.46	\$250.72	\$273.99	\$342.29	\$369.08
78	to	\$184.46	\$210.55	\$219.33	\$245.41	\$271.50	\$297.58	\$372.70	\$402.73
88	to	\$208.60	\$239.25	\$249.04	\$279.69	\$310.34	\$341.00	\$403.50	\$436.78
98	to	\$221.90	\$255.55	\$265.82	\$299.47	\$333.12	\$366.77	\$434.74	\$471.27
108	to	\$238.29	\$275.54	\$286.43	\$323.68	\$360.93	\$398.19	\$472.76	\$513.20

Bio Comfort® foam fill pricing applies to Standard and Premium Indoor fill styles. For up-to-date pricing, please visit www.DesignerCustomSource.com.

Suggested Retail Labor for

Bench Cushions with Bio Comfort® Foam Fill

Zippers / Ties / Knife and Boxed Edges

PRICING

Depth		26" - 28 1/2"							
Thickness (Measured in Inches)		2	3	4	5	6	7	8	
Width		KNIFE	KNIFE	BOXED	BOXED	BOXED	BOXED	BOXED	
26	to	\$109.89	\$118.89	\$124.64	\$133.64	\$142.65	\$151.65	\$188.36	\$198.92
28	to	\$113.97	\$124.08	\$129.94	\$140.05	\$150.16	\$160.27	\$199.76	\$211.62
32	to	\$118.10	\$129.31	\$135.29	\$146.51	\$157.72	\$168.94	\$211.21	\$224.36
36	to	\$122.26	\$134.58	\$140.68	\$153.00	\$165.32	\$177.64	\$222.71	\$237.16
40	to	\$126.45	\$139.88	\$146.10	\$159.53	\$172.96	\$186.39	\$234.26	\$250.01
44	to	\$139.70	\$155.24	\$162.02	\$177.56	\$193.10	\$208.63	\$260.33	\$278.37
48	to	\$144.27	\$160.99	\$167.91	\$184.63	\$201.35	\$218.07	\$272.67	\$292.08
52	to	\$148.88	\$166.79	\$173.84	\$191.75	\$209.66	\$227.56	\$285.06	\$305.86
56	to	\$153.54	\$172.63	\$179.82	\$198.91	\$218.01	\$237.10	\$297.51	\$319.68
60	to	\$160.58	\$181.45	\$188.86	\$209.74	\$230.61	\$251.48	\$316.28	\$340.52
66	to	\$178.55	\$202.66	\$210.79	\$234.90	\$259.02	\$283.13	\$353.80	\$381.57
72	to	\$186.27	\$212.28	\$220.65	\$246.66	\$272.67	\$298.68	\$373.89	\$403.85
78	to	\$193.32	\$228.50	\$237.29	\$266.47	\$295.64	\$324.82	\$407.63	\$441.23
88	to	\$225.59	\$259.90	\$269.69	\$304.00	\$338.31	\$372.62	\$441.81	\$479.05
98	to	\$240.15	\$277.83	\$288.10	\$325.78	\$363.46	\$401.14	\$476.43	\$517.33
108	to	\$258.07	\$299.80	\$310.69	\$352.42	\$394.15	\$435.87	\$518.54	\$563.84

Bio Comfort® foam fill pricing applies to Standard and Premium Indoor fill styles. For up-to-date pricing, please visit www.DesignerCustomSource.com.

Suggested Retail Labor for

Bench Cushions with Bio Comfort® Foam Fill

Zippers / Ties / Knife and Boxed Edges

PRICING

Depth		29"–31 1/2"							
Thickness (Measured in Inches)		2	3	4	5	6	7	8	
Width		KNIFE	KNIFE	BOXED	BOXED	BOXED	BOXED	BOXED	
26	to	\$117.13	\$127.00	\$132.75	\$142.62	\$152.50	\$162.37	\$201.94	\$213.52
28	to	\$121.59	\$132.69	\$138.55	\$149.65	\$160.76	\$171.86	\$214.51	\$227.52
32	to	\$126.09	\$138.42	\$144.39	\$156.73	\$169.06	\$181.39	\$227.12	\$241.58
36	to	\$130.62	\$144.18	\$150.28	\$163.84	\$177.40	\$190.96	\$239.78	\$255.68
40	to	\$135.20	\$149.99	\$156.21	\$171.00	\$185.79	\$200.58	\$252.50	\$269.84
44	to	\$149.45	\$166.58	\$173.36	\$190.49	\$207.61	\$224.74	\$280.88	\$300.77
48	to	\$154.43	\$172.88	\$179.79	\$198.23	\$216.68	\$235.12	\$294.46	\$315.88
52	to	\$159.46	\$179.21	\$186.27	\$206.03	\$225.79	\$245.55	\$308.10	\$331.04
56	to	\$164.52	\$185.60	\$192.80	\$213.87	\$234.95	\$256.03	\$321.80	\$346.27
60	to	\$172.20	\$195.25	\$202.66	\$225.72	\$248.77	\$271.82	\$342.44	\$369.21
66	to	\$191.59	\$218.23	\$226.36	\$253.01	\$279.66	\$306.31	\$383.40	\$414.09
72	to	\$199.98	\$228.74	\$237.11	\$265.87	\$294.62	\$323.38	\$405.49	\$438.61
78	to	\$214.18	\$246.46	\$255.24	\$287.52	\$319.79	\$352.07	\$442.57	\$479.74
88	to	\$242.59	\$280.55	\$290.34	\$328.31	\$366.27	\$404.24	\$480.11	\$521.33
98	to	\$258.40	\$300.10	\$310.38	\$352.09	\$393.79	\$435.50	\$518.11	\$563.40
108	to	\$277.85	\$324.06	\$334.95	\$381.15	\$427.36	\$473.56	\$564.32	\$614.49

Bio Comfort® foam fill pricing applies to Standard and Premium Indoor fill styles. For up-to-date pricing, please visit www.DesignerCustomSource.com.

Suggested Retail Labor for

Bench Cushions with Bio Comfort® Foam Fill

Zippers / Ties / Knife and Boxed Edges

PRICING

Depth		32" - 35 1/2"							
Thickness (Measured in Inches)		2	3	4	5	6	7	8	
Width		KNIFE	BOXED	KNIFE	BOXED	KNIFE	BOXED	KNIFE	BOXED
26	to	\$124.37	\$128.68	\$135.11	\$140.86	\$151.60	\$162.35	\$173.09	\$215.53
28	to	\$129.20	\$133.60	\$141.30	\$147.16	\$159.25	\$171.35	\$183.44	\$229.25
32	to	\$134.07	\$138.56	\$147.52	\$153.50	\$166.95	\$180.39	\$193.84	\$243.03
36	to	\$138.99	\$143.56	\$153.79	\$159.88	\$174.68	\$189.48	\$204.28	\$256.86
40	to	\$143.94	\$148.60	\$160.09	\$166.31	\$182.47	\$198.62	\$214.77	\$270.74
44	to	\$159.21	\$164.29	\$177.92	\$184.70	\$203.42	\$222.13	\$240.85	\$301.43
48	to	\$164.59	\$169.78	\$184.76	\$191.67	\$211.84	\$232.00	\$252.16	\$339.67
52	to	\$170.03	\$175.32	\$191.64	\$198.70	\$220.31	\$241.92	\$263.53	\$331.14
56	to	\$175.51	\$180.91	\$198.57	\$205.77	\$228.83	\$251.89	\$274.95	\$346.08
60	to	\$183.81	\$189.37	\$209.05	\$216.46	\$241.70	\$266.93	\$292.17	\$368.60
66	to	\$204.62	\$210.72	\$233.80	\$241.93	\$271.11	\$300.30	\$329.48	\$413.01
72	to	\$213.70	\$219.98	\$245.20	\$253.57	\$285.07	\$316.58	\$348.08	\$437.37
78	to	\$229.04	\$235.63	\$264.41	\$273.20	\$308.57	\$343.94	\$379.31	\$477.51
88	to	\$259.58	\$266.92	\$301.20	\$310.99	\$352.61	\$394.24	\$435.86	\$518.41
98	to	\$276.64	\$284.35	\$322.38	\$332.66	\$378.39	\$424.13	\$469.87	\$559.80
108	to	\$297.63	\$305.80	\$348.31	\$359.21	\$409.89	\$460.57	\$511.25	\$610.10

Bio Comfort® foam fill pricing applies to Standard and Premium Indoor fill styles. For up-to-date pricing, please visit www.DesignerCustomSource.com.

Suggested Retail Labor for

Bench Cushions with Bio Comfort® Foam Fill

Zippers / Ties / Knife and Boxed Edges

PRICING

Depth		36"–39 1/2"								
Thickness (Measured in Inches)		2	2	3	3	4	5	6	7	8
Width		KNIFE	BOXED	KNIFE	BOXED	BOXED	BOXED	BOXED	BOXED	BOXED
26	to	\$134.03	\$138.34	\$145.93	\$151.67	\$163.58	\$175.48	\$187.38	\$233.64	\$247.59
28	to	\$139.36	\$143.75	\$152.77	\$158.63	\$172.05	\$185.47	\$198.89	\$248.91	\$264.64
32	to	\$144.72	\$149.21	\$159.66	\$165.64	\$180.57	\$195.51	\$210.44	\$264.23	\$281.74
36	to	\$150.14	\$154.71	\$166.59	\$172.69	\$189.14	\$205.59	\$222.05	\$279.62	\$298.91
40	to	\$155.60	\$160.26	\$173.57	\$179.79	\$197.76	\$215.73	\$233.70	\$295.06	\$316.13
44	to	\$172.21	\$177.30	\$193.04	\$199.82	\$220.66	\$241.49	\$262.33	\$328.83	\$353.02
48	to	\$178.14	\$183.33	\$200.60	\$207.52	\$229.98	\$252.43	\$274.89	\$345.31	\$371.39
52	to	\$184.13	\$189.42	\$208.21	\$215.26	\$239.35	\$263.43	\$287.51	\$361.85	\$389.82
56	to	\$190.16	\$195.56	\$215.87	\$223.07	\$248.77	\$274.48	\$300.19	\$378.46	\$408.32
60	to	\$199.29	\$204.85	\$227.44	\$234.85	\$263.00	\$291.15	\$319.30	\$403.48	\$436.17
66	to	\$222.00	\$228.10	\$254.56	\$262.69	\$295.25	\$327.82	\$360.38	\$452.48	\$489.97
72	to	\$231.98	\$238.26	\$267.15	\$275.52	\$310.68	\$345.84	\$381.01	\$479.22	\$519.72
78	to	\$248.85	\$255.44	\$288.35	\$297.14	\$336.64	\$376.14	\$415.64	\$524.10	\$569.58
88	to	\$282.24	\$289.58	\$328.73	\$338.52	\$385.02	\$431.52	\$478.02	\$569.48	\$619.96
98	to	\$300.97	\$308.68	\$352.08	\$362.36	\$413.47	\$464.58	\$515.69	\$615.38	\$670.88
108	to	\$324.01	\$332.18	\$380.66	\$391.55	\$448.20	\$504.85	\$561.51	\$671.14	\$732.65

Bio Comfort® foam fill pricing applies to Standard and Premium Indoor fill styles. For up-to-date pricing, please visit www.DesignerCustomSource.com.

Suggested Retail Labor for

Bench Cushions with Bio Comfort® Foam Fill

Zippers / Ties / Knife and Boxed Edges

PRICING

Depth		40"–43 1/2"									
Thickness (Measured in Inches)		2	3	3	4	5	6	7	8		
Width		KNIFE	BOXED	KNIFE	BOXED	BOXED	BOXED	BOXED	BOXED	BOXED	
26	to	\$143.69	\$147.99	\$156.75	\$162.49	\$175.55	\$188.61	\$201.67	\$251.75	\$267.06	
28	to	\$149.51	\$153.90	\$164.25	\$170.11	\$184.85	\$199.59	\$214.33	\$268.57	\$285.85	
32	to	\$155.38	\$159.86	\$171.80	\$177.78	\$194.20	\$210.62	\$227.04	\$285.44	\$304.70	
36	to	\$161.29	\$165.86	\$179.40	\$185.49	\$203.60	\$221.70	\$239.81	\$302.38	\$323.61	
40	to	\$167.25	\$171.92	\$187.04	\$193.26	\$213.05	\$232.84	\$252.62	\$319.38	\$342.58	
44	to	\$185.21	\$190.30	\$208.17	\$214.95	\$237.90	\$260.85	\$283.80	\$356.23	\$382.89	
48	to	\$191.69	\$196.88	\$216.44	\$223.36	\$248.11	\$272.87	\$297.62	\$374.37	\$403.11	
52	to	\$198.23	\$203.52	\$224.78	\$231.83	\$258.39	\$284.94	\$311.49	\$392.57	\$423.41	
56	to	\$204.81	\$210.21	\$233.17	\$240.36	\$268.72	\$297.07	\$325.43	\$410.85	\$443.77	
60	to	\$214.78	\$220.34	\$245.84	\$253.25	\$284.31	\$315.37	\$346.42	\$438.37	\$474.44	
66	to	\$239.38	\$245.48	\$275.32	\$283.45	\$319.39	\$355.33	\$391.28	\$491.95	\$533.34	
72	to	\$250.27	\$256.55	\$289.09	\$297.46	\$336.29	\$375.11	\$413.93	\$521.36	\$566.06	
78	to	\$268.66	\$275.25	\$312.29	\$321.08	\$364.71	\$408.34	\$451.97	\$570.68	\$620.92	
88	to	\$304.89	\$312.23	\$356.27	\$366.05	\$417.43	\$468.80	\$520.18	\$620.55	\$676.32	
98	to	\$325.30	\$333.01	\$381.79	\$392.06	\$448.55	\$505.03	\$561.51	\$670.97	\$732.29	
108	to	\$350.38	\$358.55	\$413.00	\$423.90	\$486.52	\$549.14	\$611.76	\$732.18	\$800.17	

Bio Comfort® foam fill pricing applies to Standard and Premium Indoor fill styles. For up-to-date pricing, please visit www.DesignerCustomSource.com.

Suggested Retail Labor for

Bench Cushions with Bio Comfort® Foam Fill

Zipper / Ties / Knife and Boxed Edges

PRICING

Depth		44"–47 1/2"									
Thickness (Measured in Inches)		2	3	4	5	6	7	8			
Width		KNIFE	BOXED	KNIFE	BOXED	KNIFE	BOXED	KNIFE	BOXED	KNIFE	BOXED
26	to	\$153.34	\$157.65	\$173.31	\$187.52	\$201.74	\$215.96	\$269.86	\$286.53		
28	to	\$159.66	\$164.06	\$181.58	\$197.65	\$213.71	\$229.78	\$288.23	\$307.06		
32	to	\$166.03	\$170.51	\$189.91	\$207.82	\$225.73	\$243.65	\$306.65	\$327.65		
36	to	\$172.44	\$177.02	\$198.30	\$218.05	\$237.81	\$257.57	\$325.14	\$348.31		
40	to	\$178.91	\$183.57	\$206.73	\$228.34	\$249.94	\$271.55	\$343.70	\$369.03		
44	to	\$198.22	\$203.30	\$230.07	\$255.14	\$280.21	\$305.28	\$383.63	\$412.75		
48	to	\$205.24	\$210.43	\$239.20	\$266.25	\$293.30	\$320.34	\$403.42	\$434.83		
52	to	\$212.32	\$217.61	\$248.40	\$277.43	\$306.45	\$335.47	\$423.29	\$456.99		
56	to	\$219.46	\$224.86	\$257.66	\$288.66	\$319.66	\$350.67	\$443.23	\$479.23		
60	to	\$230.26	\$235.82	\$271.65	\$305.61	\$339.58	\$373.55	\$473.25	\$512.70		
66	to	\$256.76	\$262.86	\$304.21	\$343.53	\$382.85	\$422.18	\$531.42	\$576.70		
72	to	\$268.56	\$274.84	\$319.41	\$361.90	\$404.38	\$446.86	\$563.49	\$612.41		
78	to	\$288.47	\$295.06	\$345.02	\$392.78	\$440.53	\$488.29	\$617.27	\$672.26		
88	to	\$327.55	\$334.89	\$393.59	\$449.84	\$506.09	\$562.34	\$671.61	\$732.69		
98	to	\$349.63	\$357.34	\$411.49	\$483.62	\$545.48	\$607.33	\$726.55	\$793.71		
108	to	\$376.76	\$384.93	\$445.35	\$524.83	\$593.42	\$662.01	\$793.22	\$867.69		

Bio Comfort® foam fill pricing applies to Standard and Premium Indoor fill styles. For up-to-date pricing, please visit www.DesignerCustomSource.com.

Suggested Retail Labor for

Bench Cushions with Bio Comfort® Foam Fill

Zippers / Ties / Knife and Boxed Edges

PRICING

Depth		48"–59 1/2"							
Thickness (Measured in Inches)		2	3	4	5	6	7	8	
Width		KNIFE	KNIFE	BOXED	BOXED	BOXED	BOXED	BOXED	
26	to	\$163.00	\$178.38	\$184.12	\$199.50	\$214.87	\$230.25	\$287.98	\$306.00
28	to	\$169.81	\$187.20	\$193.06	\$210.45	\$227.83	\$245.22	\$307.88	\$328.27
32	to	\$176.68	\$196.08	\$202.05	\$221.45	\$240.85	\$260.25	\$327.86	\$350.60
36	to	\$183.60	\$205.01	\$211.10	\$232.51	\$253.92	\$275.33	\$347.90	\$373.00
40	to	\$190.57	\$213.99	\$220.21	\$243.63	\$267.05	\$290.47	\$368.02	\$395.48
44	to	\$211.22	\$238.41	\$245.19	\$272.38	\$299.57	\$326.76	\$411.03	\$442.61
48	to	\$218.79	\$248.13	\$255.05	\$284.39	\$313.73	\$343.07	\$432.48	\$466.55
52	to	\$226.42	\$257.92	\$264.97	\$296.46	\$327.96	\$359.45	\$454.00	\$490.58
56	to	\$234.11	\$267.76	\$274.96	\$308.61	\$342.25	\$375.90	\$475.61	\$514.68
60	to	\$245.75	\$282.63	\$290.04	\$326.92	\$363.80	\$400.68	\$508.13	\$550.96
66	to	\$274.14	\$316.85	\$324.97	\$367.67	\$410.37	\$453.07	\$570.89	\$620.06
72	to	\$286.84	\$332.99	\$341.36	\$387.50	\$433.65	\$479.79	\$605.62	\$658.76
78	to	\$308.28	\$360.17	\$368.96	\$420.85	\$472.73	\$524.62	\$663.86	\$723.60
88	to	\$350.20	\$411.33	\$421.12	\$482.25	\$543.37	\$604.50	\$722.68	\$789.05
98	to	\$373.96	\$441.19	\$451.47	\$518.70	\$585.93	\$653.16	\$782.13	\$855.12
108	to	\$403.13	\$477.69	\$488.59	\$563.14	\$637.70	\$712.26	\$854.26	\$935.21

Bio Comfort® foam fill pricing applies to Standard and Premium Indoor fill styles. For up-to-date pricing, please visit www.DesignerCustomSource.com.

Suggested Retail Labor for

Bench Cushions with Bio Comfort® Foam Fill

Zippers / Ties / Knife and Boxed Edges

PRICING

Depth		60"-79 1/2"							
Thickness (Measured in Inches)		2	3	4	5	6	7	8	
Width		KNIFE	BOXED	KNIFE	BOXED	KNIFE	BOXED	KNIFE	BOXED
26	to	\$191.97	\$196.28	\$210.82	\$216.57	\$235.42	\$254.27	\$273.12	\$342.31
28	to	\$200.27	\$204.66	\$221.63	\$227.49	\$248.84	\$270.20	\$291.55	\$366.86
32	to	\$208.63	\$213.11	\$232.49	\$238.47	\$262.33	\$286.19	\$310.05	\$391.49
36	to	\$217.05	\$221.63	\$243.42	\$249.52	\$275.88	\$302.25	\$328.62	\$416.19
40	to	\$225.54	\$230.20	\$254.41	\$260.63	\$289.50	\$318.38	\$347.25	\$440.97
44	to	\$250.23	\$255.32	\$283.77	\$290.55	\$324.10	\$357.64	\$391.19	\$493.24
48	to	\$259.44	\$264.62	\$295.66	\$302.58	\$338.80	\$375.03	\$411.25	\$519.65
52	to	\$268.72	\$274.01	\$307.62	\$314.68	\$353.58	\$392.49	\$431.39	\$546.15
56	to	\$278.07	\$283.46	\$319.66	\$326.85	\$368.44	\$410.03	\$451.61	\$572.75
60	to	\$292.21	\$297.76	\$337.82	\$345.23	\$390.84	\$436.45	\$482.06	\$612.78
66	to	\$326.29	\$332.38	\$379.13	\$387.25	\$440.09	\$492.93	\$545.77	\$689.31
72	to	\$341.70	\$347.98	\$398.83	\$407.20	\$464.33	\$521.45	\$578.58	\$732.02
78	to	\$367.72	\$374.31	\$431.99	\$440.78	\$505.05	\$569.33	\$633.60	\$803.61
88	to	\$418.17	\$425.51	\$493.93	\$503.72	\$579.47	\$655.23	\$730.98	\$875.89
98	to	\$446.95	\$454.66	\$530.30	\$540.58	\$623.93	\$707.27	\$790.62	\$948.88
108	to	\$482.26	\$490.43	\$574.73	\$585.62	\$678.09	\$770.55	\$863.02	\$1,037.38

Bio Comfort® foam fill pricing applies to Standard and Premium Indoor fill styles. For up-to-date pricing, please visit www.DesignerCustomSource.com.

Suggested Retail Labor for

Bench Cushions with Bio Comfort® Foam Fill

Zippers / Ties / Knife and Boxed Edges

PRICING

Depth		80"									
Thickness (Measured in Inches)		2	2	3	3	4	5	6	7	8	
Width		KNIFE	BOXED	KNIFE	BOXED	KNIFE	BOXED	KNIFE	BOXED	KNIFE	BOXED
26	to	\$240.25	\$244.56	\$264.90	\$270.64	\$295.29	\$319.93	\$344.57	\$432.87	\$461.77	
28	to	\$251.03	\$255.43	\$279.00	\$284.86	\$312.84	\$340.81	\$368.78	\$465.15	\$497.95	
32	to	\$261.89	\$266.37	\$293.19	\$299.16	\$330.46	\$361.76	\$393.06	\$497.53	\$534.22	
36	to	\$272.81	\$277.39	\$307.44	\$313.54	\$348.17	\$382.80	\$417.43	\$530.00	\$570.60	
40	to	\$283.82	\$288.49	\$321.78	\$328.00	\$365.96	\$403.92	\$441.87	\$562.56	\$607.07	
44	to	\$315.25	\$320.33	\$359.38	\$366.16	\$410.30	\$454.44	\$498.57	\$630.24	\$681.50	
48	to	\$327.18	\$332.37	\$374.88	\$381.80	\$429.49	\$477.19	\$524.89	\$664.94	\$720.33	
52	to	\$339.21	\$344.50	\$390.47	\$397.52	\$448.78	\$500.04	\$551.29	\$699.74	\$759.26	
56	to	\$351.32	\$356.72	\$406.14	\$413.34	\$468.16	\$522.98	\$577.80	\$734.65	\$798.32	
60	to	\$369.63	\$375.19	\$429.80	\$437.21	\$497.37	\$557.53	\$617.70	\$787.20	\$857.06	
66	to	\$413.19	\$419.29	\$482.93	\$491.05	\$560.79	\$630.53	\$700.26	\$886.67	\$966.97	
72	to	\$433.14	\$439.41	\$508.56	\$516.93	\$592.36	\$667.79	\$743.22	\$942.69	\$1,029.54	
78	to	\$466.77	\$473.36	\$551.69	\$560.48	\$645.40	\$730.32	\$815.23	\$1,036.54	\$1,134.33	
88	to	\$531.46	\$538.80	\$631.59	\$641.38	\$741.51	\$841.65	\$941.79	\$1,131.23	\$1,239.95	
98	to	\$568.61	\$576.31	\$678.82	\$689.09	\$799.31	\$909.52	\$1,019.73	\$1,226.80	\$1,346.46	
108	to	\$614.14	\$622.31	\$736.45	\$747.34	\$869.66	\$991.97	\$1,114.28	\$1,342.58	\$1,475.38	

Bio Comfort® foam fill pricing applies to Standard and Premium Indoor fill styles. For up-to-date pricing, please visit www.DesignerCustomSource.com.

Suggested Retail Labor for

Bench Cushions with Bio Comfort® Foam Fill

Zippers / Ties / Single Cording / Double Cording

PRICING

Depth		17"–19 1/2"									
Thickness (Measured in Inches)		2	2	3	3	4	5	6	7	8	
Width		SGL CRD	DBL CRD	SGL CRD	DBL CRD	SGL CRD	DBL CRD	SGL CRD	DBL CRD	SGL CRD	DBL CRD
26	to	\$95.91	\$107.98	\$102.31	\$115.81	\$122.21	\$128.61	\$135.01	\$165.79	\$173.29	
28	to	\$99.85	\$112.95	\$106.98	\$121.55	\$128.68	\$135.81	\$142.95	\$175.96	\$184.32	
32	to	\$103.81	\$117.95	\$111.68	\$127.31	\$135.18	\$143.05	\$150.91	\$186.16	\$195.38	
36	to	\$107.81	\$122.98	\$116.41	\$133.11	\$141.71	\$150.31	\$158.92	\$196.40	\$206.49	
40	to	\$111.83	\$128.04	\$121.17	\$138.94	\$148.28	\$157.62	\$166.96	\$206.69	\$217.64	
44	to	\$123.88	\$142.32	\$134.65	\$154.79	\$165.56	\$176.33	\$187.10	\$229.79	\$242.30	
48	to	\$128.25	\$147.81	\$139.81	\$161.09	\$172.65	\$184.21	\$195.77	\$240.77	\$254.20	
52	to	\$132.65	\$153.33	\$145.00	\$167.44	\$179.79	\$192.13	\$204.48	\$251.80	\$266.14	
56	to	\$137.09	\$158.88	\$150.23	\$173.82	\$186.96	\$200.10	\$213.23	\$262.88	\$278.14	
60	to	\$143.80	\$167.29	\$158.12	\$183.46	\$197.78	\$212.11	\$226.43	\$279.58	\$296.22	
66	to	\$160.30	\$187.12	\$176.81	\$205.66	\$222.17	\$238.68	\$255.19	\$312.87	\$331.88	
72	to	\$167.61	\$196.25	\$185.39	\$216.12	\$233.89	\$251.67	\$269.44	\$330.74	\$351.21	
78	to	\$179.97	\$211.58	\$199.85	\$233.66	\$253.55	\$273.44	\$293.33	\$360.67	\$383.57	
88	to	\$204.26	\$240.96	\$227.60	\$266.75	\$290.09	\$313.42	\$336.76	\$390.96	\$416.30	
98	to	\$217.94	\$257.84	\$243.53	\$286.00	\$311.59	\$337.17	\$362.76	\$421.64	\$449.42	
108	to	\$234.73	\$278.48	\$263.03	\$309.51	\$337.80	\$366.10	\$394.40	\$458.93	\$489.65	

Bio Comfort® foam fill pricing applies to Standard and Premium Indoor fill styles. For up-to-date pricing, please visit www.DesignerCustomSource.com.

Suggested Retail Labor for

Bench Cushions with Bio Comfort® Foam Fill

Zippers / Ties / Single Cording / Double Cording

PRICING

Depth		20" - 22 1/2"								
Thickness (Measured in Inches)		2	2	3	3	4	5	6	7	8
Width		SGL CRD	DBL CRD	SGL CRD	DBL CRD	SGL CRD	DBL CRD	SGL CRD	DBL CRD	DBL CRD
26	to	\$103.88	\$116.66	\$111.14	\$125.36	\$132.63	\$139.90	\$147.17	\$181.06	\$189.58
28	to	\$108.18	\$122.00	\$116.31	\$131.59	\$139.71	\$147.84	\$155.97	\$192.38	\$201.91
32	to	\$112.52	\$127.37	\$121.50	\$137.85	\$146.83	\$155.82	\$164.80	\$203.75	\$214.28
36	to	\$116.89	\$132.78	\$126.73	\$144.15	\$153.99	\$163.83	\$173.68	\$215.16	\$226.70
40	to	\$121.29	\$138.22	\$131.99	\$150.48	\$161.18	\$171.88	\$182.59	\$226.61	\$239.16
44	to	\$134.40	\$153.61	\$146.76	\$167.66	\$180.02	\$192.38	\$204.74	\$252.12	\$266.47
48	to	\$139.18	\$159.50	\$152.46	\$174.51	\$187.79	\$201.07	\$214.35	\$264.35	\$279.77
52	to	\$143.99	\$165.44	\$158.19	\$181.40	\$195.60	\$209.80	\$224.00	\$276.62	\$293.11
56	to	\$148.85	\$171.41	\$163.97	\$188.33	\$203.45	\$218.57	\$233.70	\$288.95	\$306.51
60	to	\$156.18	\$180.44	\$172.68	\$198.79	\$215.30	\$231.81	\$248.31	\$307.53	\$326.70
66	to	\$174.15	\$201.79	\$193.20	\$222.86	\$241.91	\$260.95	\$280.00	\$344.35	\$366.28
72	to	\$182.15	\$211.60	\$202.67	\$234.21	\$254.73	\$275.25	\$295.77	\$364.22	\$387.85
78	to	\$195.64	\$228.07	\$218.63	\$253.25	\$276.24	\$299.22	\$322.21	\$397.49	\$423.96
88	to	\$222.12	\$259.69	\$249.11	\$289.13	\$316.13	\$343.12	\$370.12	\$431.15	\$460.46
98	to	\$237.06	\$277.82	\$266.67	\$310.01	\$339.63	\$369.24	\$398.86	\$465.21	\$497.37
108	to	\$255.38	\$300.00	\$288.15	\$335.50	\$368.27	\$401.05	\$433.82	\$506.59	\$542.17

Bio Comfort® foam fill pricing applies to Standard and Premium Indoor fill styles. For up-to-date pricing, please visit www.DesignerCustomSource.com.

Suggested Retail Labor for

Bench Cushions with Bio Comfort® Foam Fill

Zippers / Ties / Single Cording / Double Cording

PRICING

Depth		23" – 25 1/2"								
Thickness (Measured in Inches)		2	2	3	3	4	5	6	7	8
Width		SGL CRD	DBL CRD	SGL CRD	DBL CRD	SGL CRD	DBL CRD	SGL CRD	DBL CRD	DBL CRD
26	to 28	\$111.84	\$125.34	\$119.97	\$134.91	\$143.05	\$151.18	\$159.32	\$196.33	\$205.87
28	to 32	\$116.51	\$131.05	\$125.63	\$141.63	\$150.75	\$159.87	\$168.99	\$208.81	\$219.50
32	to 36	\$121.23	\$136.80	\$131.33	\$148.39	\$158.49	\$168.59	\$178.69	\$221.34	\$233.18
36	to 40	\$125.97	\$142.58	\$137.05	\$155.19	\$166.27	\$177.35	\$188.43	\$233.91	\$246.91
40	to 44	\$130.75	\$148.40	\$142.82	\$162.02	\$174.09	\$186.15	\$198.22	\$246.54	\$260.68
44	to 48	\$144.92	\$164.90	\$158.87	\$180.54	\$194.49	\$208.44	\$222.39	\$274.46	\$290.65
48	to 52	\$150.11	\$171.20	\$165.11	\$187.93	\$202.93	\$217.93	\$232.93	\$287.92	\$305.34
52	to 56	\$155.33	\$177.54	\$171.39	\$195.36	\$211.42	\$227.47	\$243.52	\$301.44	\$320.09
56	to 60	\$160.60	\$183.93	\$177.71	\$202.84	\$219.94	\$237.05	\$254.16	\$315.02	\$334.89
60	to 66	\$168.56	\$193.58	\$187.25	\$214.13	\$232.81	\$251.50	\$270.19	\$335.47	\$357.18
66	to 72	\$188.00	\$216.46	\$209.58	\$240.07	\$261.65	\$283.23	\$304.81	\$375.84	\$400.69
72	to 78	\$196.68	\$226.95	\$219.94	\$252.31	\$275.57	\$298.84	\$322.10	\$397.70	\$424.49
78	to 88	\$211.32	\$244.57	\$237.40	\$272.84	\$298.92	\$325.00	\$351.09	\$434.31	\$464.34
88	to 98	\$239.98	\$278.42	\$270.63	\$311.51	\$342.17	\$372.82	\$403.47	\$471.33	\$504.61
98	to 108	\$256.17	\$297.80	\$289.82	\$334.02	\$367.67	\$401.31	\$434.96	\$508.78	\$545.31
108	to 120	\$276.02	\$321.51	\$313.28	\$361.49	\$398.74	\$435.99	\$473.24	\$554.25	\$594.70

Bio Comfort® foam fill pricing applies to Standard and Premium Indoor fill styles. For up-to-date pricing, please visit www.DesignerCustomSource.com.

Suggested Retail Labor for

Bench Cushions with Bio Comfort® Foam Fill

Zippers / Ties / Single Cording / Double Cording

PRICING

Depth		26" - 28 1/2"											
Thickness (Measured in Inches)		2	2	3	3	4	4	5	5	6	7	8	
Width		SGL CRD	DBL CRD	SGL CRD	DBL CRD	SGL CRD	DBL CRD	SGL CRD	DBL CRD	SGL CRD	DBL CRD	SGL CRD	DBL CRD
26	to 28	\$119.80	\$124.11	\$128.80	\$134.55	\$143.55	\$152.56	\$161.56	\$169.98	\$172.10	\$182.67	\$193.28	\$210.54
28	to 32	\$124.85	\$130.19	\$134.96	\$141.76	\$151.88	\$161.99	\$172.10	\$213.62	\$182.67	\$193.28	\$241.05	\$225.47
32	to 36	\$129.93	\$136.31	\$141.15	\$149.02	\$160.24	\$171.45	\$182.67	\$227.31	\$193.28	\$203.94	\$254.84	\$240.46
36	to 40	\$135.05	\$142.47	\$147.38	\$156.32	\$168.64	\$180.96	\$193.28	\$241.05	\$203.94	\$213.90	\$284.49	\$255.50
40	to 44	\$140.21	\$148.67	\$153.64	\$163.65	\$177.08	\$190.51	\$203.94	\$254.84	\$213.90	\$224.20	\$299.20	\$270.58
44	to 48	\$155.44	\$165.59	\$170.98	\$182.82	\$198.36	\$213.90	\$229.44	\$284.49	\$240.92	\$252.45	\$313.96	\$302.53
48	to 52	\$161.04	\$172.30	\$177.76	\$190.75	\$207.48	\$224.20	\$240.92	\$299.20	\$252.45	\$264.03	\$328.79	\$318.62
52	to 56	\$166.68	\$179.06	\$184.58	\$198.73	\$216.64	\$234.54	\$252.45	\$313.96	\$264.03	\$281.48	\$351.12	\$334.76
56	to 60	\$172.36	\$185.86	\$191.45	\$206.75	\$225.84	\$244.94	\$264.03	\$328.79	\$281.48	\$294.22	\$368.69	\$350.96
60	to 66	\$180.94	\$196.14	\$201.81	\$218.86	\$239.74	\$260.61	\$281.48	\$351.12	\$294.22	\$318.34	\$408.15	\$375.35
66	to 72	\$201.86	\$219.85	\$225.97	\$245.99	\$270.11	\$294.22	\$318.34	\$394.34	\$311.15	\$337.16	\$458.15	\$422.10
72	to 78	\$211.21	\$231.02	\$237.22	\$259.12	\$285.14	\$311.15	\$337.16	\$418.20	\$339.51	\$368.69	\$491.75	\$448.15
78	to 88	\$226.99	\$249.78	\$256.17	\$281.16	\$310.33	\$339.51	\$368.69	\$458.15	\$390.55	\$424.86	\$535.78	\$491.75
88	to 98	\$257.84	\$285.18	\$292.14	\$321.94	\$356.24	\$390.55	\$424.86	\$535.78	\$421.42	\$459.10	\$580.27	\$535.78
98	to 108	\$275.28	\$305.82	\$312.96	\$346.07	\$383.75	\$421.42	\$459.10	\$580.27	\$458.98	\$500.71	\$634.23	\$580.27
108	to 120	\$296.67	\$331.07	\$338.40	\$375.52	\$417.25	\$458.98	\$500.71	\$634.23				\$634.23

Bio Comfort® foam fill pricing applies to Standard and Premium Indoor fill styles. For up-to-date pricing, please visit www.DesignerCustomSource.com.

Suggested Retail Labor for

Bench Cushions with Bio Comfort® Foam Fill

Zippers / Ties / Single Cording / Double Cording

PRICING

Depth		29"–31 1/2"													
Thickness (Measured in Inches)		2	2	3	3	4	4	5	5	6	6	7	7	8	8
Width		SGL CRD	DBL CRD	SGL CRD	DBL CRD	SGL CRD	DBL CRD	SGL CRD	DBL CRD	SGL CRD	DBL CRD	SGL CRD	DBL CRD	SGL CRD	DBL CRD
26	to 28	\$127.76	\$142.69	\$137.63	\$154.01	\$163.88	\$173.75	\$183.63	\$193.50	\$203.37	\$213.24	\$223.11	\$232.98	\$242.85	\$252.72
28	to 32	\$133.18	\$149.15	\$144.28	\$161.72	\$172.82	\$183.92	\$195.03	\$206.13	\$217.24	\$228.34	\$239.44	\$250.54	\$261.64	\$272.74
32	to 36	\$138.64	\$155.65	\$150.97	\$169.47	\$181.80	\$194.13	\$206.47	\$218.80	\$231.13	\$243.46	\$255.79	\$268.12	\$280.45	\$292.78
36	to 40	\$144.14	\$162.18	\$157.70	\$177.27	\$190.83	\$204.39	\$217.95	\$231.51	\$245.07	\$258.63	\$272.19	\$285.75	\$299.31	\$312.87
40	to 44	\$149.67	\$168.76	\$164.47	\$185.10	\$199.90	\$214.69	\$229.48	\$244.27	\$259.06	\$273.85	\$288.64	\$303.43	\$318.22	\$333.01
44	to 48	\$165.96	\$187.47	\$183.09	\$206.29	\$223.42	\$240.55	\$257.67	\$274.80	\$291.93	\$309.06	\$326.19	\$343.32	\$360.45	\$377.58
48	to 52	\$171.97	\$194.59	\$190.41	\$214.77	\$233.21	\$251.65	\$270.09	\$288.53	\$306.97	\$325.41	\$343.85	\$362.29	\$380.73	\$399.17
52	to 56	\$178.02	\$201.76	\$197.78	\$223.29	\$243.05	\$262.80	\$282.56	\$302.31	\$322.07	\$341.82	\$361.58	\$381.34	\$401.10	\$420.86
56	to 60	\$184.11	\$208.98	\$205.19	\$231.85	\$252.93	\$274.01	\$295.09	\$316.17	\$337.25	\$358.33	\$379.41	\$400.49	\$421.57	\$442.65
60	to 66	\$193.32	\$219.88	\$216.38	\$244.79	\$267.84	\$290.90	\$313.95	\$337.00	\$360.05	\$383.10	\$406.15	\$429.20	\$452.25	\$475.30
66	to 72	\$215.71	\$245.80	\$242.36	\$274.48	\$301.12	\$327.77	\$354.42	\$381.06	\$407.71	\$434.35	\$460.99	\$487.63	\$514.27	\$540.91
72	to 78	\$225.74	\$257.65	\$254.50	\$288.50	\$317.25	\$346.01	\$374.77	\$403.52	\$432.28	\$461.03	\$489.79	\$518.54	\$547.29	\$576.04
78	to 88	\$242.67	\$277.55	\$274.94	\$312.02	\$344.30	\$376.57	\$408.84	\$441.12	\$473.40	\$505.68	\$537.96	\$570.24	\$602.52	\$634.80
88	to 98	\$275.70	\$315.87	\$313.66	\$356.28	\$394.25	\$432.21	\$470.18	\$508.15	\$546.12	\$584.09	\$622.06	\$660.03	\$698.00	\$735.97
98	to 108	\$294.40	\$337.76	\$336.11	\$382.04	\$423.75	\$465.46	\$507.16	\$548.87	\$590.58	\$632.29	\$674.00	\$715.71	\$757.42	\$799.13
108	to 120	\$317.32	\$364.55	\$363.53	\$413.47	\$459.68	\$505.88	\$552.09	\$598.29	\$644.50	\$690.71	\$736.92	\$783.13	\$829.34	\$875.55

Bio Comfort® foam fill pricing applies to Standard and Premium Indoor fill styles. For up-to-date pricing, please visit www.DesignerCustomSource.com.

Suggested Retail Labor for

Bench Cushions with Bio Comfort® Foam Fill

Zippers / Ties / Single Cording / Double Cording

PRICING

Depth		32" - 35 1/2"													
Thickness (Measured in Inches)		2	2	3	3	4	4	5	5	6	6	7	7	8	8
Width		SGL CRD	DBL CRD	SGL CRD	DBL CRD	SGL CRD	DBL CRD	SGL CRD	DBL CRD	SGL CRD	DBL CRD	SGL CRD	DBL CRD	SGL CRD	DBL CRD
26	to 28	\$135.72	\$151.37	\$146.46	\$163.55	\$174.30	\$185.04	\$195.78	\$242.13	\$195.78	\$242.13	\$254.73	\$254.73	\$254.73	\$254.73
28	to 32	\$141.51	\$158.20	\$153.61	\$171.76	\$183.86	\$195.95	\$208.05	\$258.10	\$208.05	\$258.10	\$272.28	\$272.28	\$272.28	\$272.28
32	to 36	\$147.34	\$165.07	\$160.79	\$180.01	\$193.46	\$206.91	\$220.35	\$274.11	\$220.35	\$274.11	\$289.88	\$289.88	\$289.88	\$289.88
36	to 40	\$153.22	\$171.98	\$168.02	\$188.31	\$203.11	\$217.91	\$232.71	\$290.18	\$232.71	\$290.18	\$307.53	\$307.53	\$307.53	\$307.53
40	to 44	\$159.14	\$178.94	\$175.29	\$196.65	\$212.80	\$228.95	\$245.11	\$306.31	\$245.11	\$306.31	\$325.24	\$325.24	\$325.24	\$325.24
44	to 48	\$176.48	\$198.76	\$195.19	\$219.17	\$237.89	\$256.60	\$275.32	\$341.46	\$275.32	\$341.46	\$363.19	\$363.19	\$363.19	\$363.19
48	to 52	\$182.90	\$206.29	\$203.06	\$228.18	\$248.35	\$268.51	\$288.67	\$358.65	\$288.67	\$358.65	\$382.07	\$382.07	\$382.07	\$382.07
52	to 56	\$189.36	\$213.87	\$210.97	\$237.25	\$258.86	\$280.47	\$302.08	\$375.91	\$302.08	\$375.91	\$401.00	\$401.00	\$401.00	\$401.00
56	to 60	\$195.87	\$221.50	\$218.93	\$246.36	\$269.42	\$292.49	\$315.55	\$393.23	\$315.55	\$393.23	\$420.01	\$420.01	\$420.01	\$420.01
60	to 66	\$205.70	\$233.03	\$230.94	\$260.12	\$285.36	\$310.60	\$335.83	\$419.31	\$335.83	\$419.31	\$448.02	\$448.02	\$448.02	\$448.02
66	to 72	\$229.56	\$260.47	\$258.74	\$291.68	\$320.86	\$350.05	\$379.23	\$470.29	\$379.23	\$470.29	\$503.90	\$503.90	\$503.90	\$503.90
72	to 78	\$240.27	\$273.00	\$271.78	\$306.59	\$338.09	\$369.59	\$401.10	\$498.14	\$401.10	\$498.14	\$534.42	\$534.42	\$534.42	\$534.42
78	to 88	\$258.34	\$294.04	\$293.71	\$331.61	\$366.98	\$402.35	\$437.72	\$544.78	\$437.72	\$544.78	\$585.51	\$585.51	\$585.51	\$585.51
88	to 98	\$293.55	\$334.59	\$335.18	\$378.66	\$420.29	\$461.91	\$503.53	\$637.07	\$503.53	\$637.07	\$689.14	\$689.14	\$689.14	\$689.14
98	to 108	\$313.51	\$357.74	\$359.25	\$406.05	\$451.79	\$497.53	\$543.26	\$697.24	\$543.26	\$697.24	\$752.26	\$752.26	\$752.26	\$752.26
108	to 120	\$337.97	\$386.06	\$388.65	\$439.47	\$490.15	\$540.83	\$591.51	\$752.26	\$591.51	\$752.26	\$817.26	\$817.26	\$817.26	\$817.26

Bio Comfort® foam fill pricing applies to Standard and Premium Indoor fill styles. For up-to-date pricing, please visit www.DesignerCustomSource.com.

Suggested Retail Labor for

Bench Cushions with Bio Comfort® Foam Fill

Zippers / Ties / Single Cording / Double Cording

PRICING

Depth		36"–39 1/2"									
Thickness (Measured in Inches)		2	2	3	3	4	5	6	7	8	
Width		SGL CRD	DBL CRD	SGL CRD	DBL CRD	SGL CRD	DBL CRD	SGL CRD	DBL CRD	SGL CRD	DBL CRD
26	to 28	\$146.34	\$162.93	\$158.24	\$176.26	\$188.17	\$200.07	\$211.97	\$262.47	\$276.42	
28	to 32	\$152.63	\$170.25	\$166.04	\$185.13	\$198.55	\$211.97	\$225.39	\$279.98	\$295.71	
32	to 36	\$158.96	\$177.62	\$173.89	\$194.05	\$208.98	\$223.92	\$238.85	\$297.54	\$315.05	
36	to 40	\$165.33	\$185.03	\$181.79	\$203.01	\$219.46	\$235.91	\$252.36	\$315.17	\$334.45	
40	to 44	\$171.75	\$192.49	\$189.73	\$212.02	\$229.99	\$247.96	\$265.93	\$332.85	\$353.92	
44	to 48	\$190.51	\$213.79	\$211.35	\$236.32	\$257.15	\$277.99	\$298.82	\$371.21	\$395.40	
48	to 52	\$197.47	\$221.87	\$219.93	\$246.05	\$268.51	\$290.97	\$313.43	\$390.06	\$416.14	
52	to 56	\$204.49	\$230.00	\$228.57	\$255.84	\$279.93	\$304.01	\$328.09	\$408.98	\$436.94	
56	to 60	\$211.55	\$238.18	\$237.26	\$265.69	\$291.40	\$317.10	\$342.81	\$427.96	\$457.81	
60	to 66	\$222.22	\$250.54	\$250.36	\$280.54	\$308.69	\$336.84	\$364.99	\$456.55	\$489.23	
66	to 72	\$248.04	\$280.00	\$280.60	\$314.60	\$347.16	\$379.72	\$412.29	\$512.25	\$549.75	
72	to 78	\$259.65	\$293.44	\$294.82	\$330.69	\$365.86	\$401.02	\$436.18	\$542.76	\$583.25	
78	to 88	\$279.25	\$316.01	\$318.75	\$357.71	\$397.21	\$436.71	\$476.21	\$593.85	\$639.33	
88	to 98	\$317.37	\$359.54	\$363.87	\$408.48	\$454.98	\$501.48	\$547.98	\$645.43	\$695.92	
98	to 108	\$339.00	\$394.36	\$390.12	\$438.04	\$489.15	\$540.26	\$591.37	\$697.55	\$753.04	
108	to 120	\$365.51	\$414.72	\$422.16	\$474.10	\$530.75	\$587.40	\$644.05	\$760.76	\$822.27	

Bio Comfort® foam fill pricing applies to Standard and Premium Indoor fill styles. For up-to-date pricing, please visit www.DesignerCustomSource.com.

Suggested Retail Labor for

Bench Cushions with Bio Comfort® Foam Fill

Zippers / Ties / Single Cording / Double Cording

PRICING

Depth		40"–43 1/2"													
Thickness (Measured in Inches)		2	2	3	3	4	4	5	5	6	6	7	7	8	8
Width		SGL CRD	DBL CRD	SGL CRD	DBL CRD	SGL CRD	DBL CRD	SGL CRD	DBL CRD	SGL CRD	DBL CRD	SGL CRD	DBL CRD	SGL CRD	DBL CRD
26	to 28	\$156.96	\$174.48	\$170.02	\$188.98	\$202.03	\$215.09	\$228.15	\$282.80	\$298.11	\$228.15	\$282.80	\$298.11	\$228.15	\$282.80
28	to 32	\$163.74	\$182.30	\$178.48	\$198.50	\$213.24	\$227.99	\$242.73	\$301.86	\$319.14	\$242.73	\$301.86	\$319.14	\$242.73	\$301.86
32	to 36	\$170.57	\$190.16	\$186.99	\$208.08	\$224.50	\$240.93	\$257.35	\$320.97	\$340.23	\$257.35	\$320.97	\$340.23	\$257.35	\$320.97
36	to 40	\$177.45	\$198.08	\$195.55	\$217.71	\$235.81	\$253.92	\$272.02	\$340.15	\$361.38	\$272.02	\$340.15	\$361.38	\$272.02	\$340.15
40	to 44	\$184.37	\$206.04	\$204.16	\$227.39	\$247.17	\$266.96	\$286.75	\$359.39	\$382.59	\$286.75	\$359.39	\$382.59	\$286.75	\$359.39
44	to 48	\$204.54	\$228.82	\$227.50	\$253.47	\$276.42	\$299.37	\$322.32	\$400.97	\$427.62	\$322.32	\$400.97	\$427.62	\$322.32	\$400.97
48	to 52	\$212.05	\$237.44	\$236.80	\$263.92	\$288.68	\$313.43	\$338.18	\$421.47	\$450.22	\$338.18	\$421.47	\$450.22	\$338.18	\$421.47
52	to 56	\$219.61	\$246.12	\$246.17	\$274.44	\$300.99	\$327.54	\$354.10	\$442.05	\$472.88	\$354.10	\$442.05	\$472.88	\$354.10	\$442.05
56	to 60	\$227.23	\$254.86	\$255.58	\$285.01	\$313.37	\$341.72	\$370.08	\$462.69	\$495.62	\$370.08	\$462.69	\$495.62	\$370.08	\$462.69
60	to 66	\$238.73	\$268.06	\$269.79	\$300.97	\$332.03	\$363.08	\$394.14	\$493.78	\$529.65	\$394.14	\$493.78	\$529.65	\$394.14	\$493.78
66	to 72	\$266.51	\$299.54	\$302.46	\$337.52	\$373.46	\$409.40	\$445.34	\$554.21	\$595.59	\$445.34	\$554.21	\$595.59	\$445.34	\$554.21
72	to 78	\$279.04	\$313.88	\$317.86	\$354.80	\$393.62	\$432.45	\$471.27	\$587.38	\$632.08	\$471.27	\$587.38	\$632.08	\$471.27	\$587.38
78	to 88	\$300.16	\$337.98	\$343.78	\$383.81	\$427.44	\$471.06	\$514.69	\$642.92	\$693.15	\$514.69	\$642.92	\$693.15	\$514.69	\$642.92
88	to 98	\$341.19	\$384.48	\$392.56	\$438.30	\$489.68	\$541.05	\$592.43	\$698.99	\$754.77	\$592.43	\$698.99	\$754.77	\$592.43	\$698.99
98	to 108	\$364.50	\$410.98	\$420.98	\$470.03	\$526.52	\$583.00	\$639.48	\$755.62	\$816.94	\$639.48	\$755.62	\$816.94	\$639.48	\$755.62
108	to 120	\$393.04	\$443.39	\$455.66	\$508.73	\$571.35	\$633.97	\$696.59	\$824.29	\$892.27	\$696.59	\$824.29	\$892.27	\$696.59	\$824.29

Bio Comfort® foam fill pricing applies to Standard and Premium Indoor fill styles. For up-to-date pricing, please visit www.DesignerCustomSource.com.

Suggested Retail Labor for

Bench Cushions with Bio Comfort® Foam Fill

Zippers / Ties / Single Cording / Double Cording

PRICING

Depth		44"–47 1/2"													
Thickness (Measured in Inches)		2	2	3	3	4	4	5	5	6	6	7	7	8	8
Width		SGL CRD	DBL CRD	SGL CRD	DBL CRD	SGL CRD	DBL CRD	SGL CRD	DBL CRD	SGL CRD	DBL CRD	SGL CRD	DBL CRD	SGL CRD	DBL CRD
26	to	\$167.58	\$186.03	\$181.79	\$201.69	\$215.90	\$230.12	\$244.34	\$260.07	\$275.85	\$291.68	\$303.14	\$319.81	\$330.12	\$342.57
28	to	\$174.86	\$194.35	\$190.92	\$211.88	\$227.94	\$244.00	\$260.07	\$275.85	\$291.68	\$303.14	\$319.81	\$330.12	\$342.57	\$357.44
32	to	\$182.18	\$202.71	\$200.10	\$222.12	\$240.03	\$257.94	\$275.85	\$291.68	\$303.14	\$319.81	\$330.12	\$342.57	\$357.44	\$372.31
36	to	\$189.56	\$211.13	\$209.32	\$232.41	\$252.17	\$271.92	\$291.68	\$303.14	\$319.81	\$330.12	\$342.57	\$357.44	\$372.31	\$387.18
40	to	\$196.99	\$219.60	\$218.60	\$242.76	\$264.36	\$285.97	\$307.57	\$320.76	\$335.89	\$351.08	\$366.34	\$381.69	\$397.04	\$412.39
44	to	\$218.58	\$243.85	\$243.65	\$270.62	\$295.69	\$320.76	\$345.83	\$362.93	\$380.10	\$397.34	\$414.57	\$431.81	\$449.04	\$466.28
48	to	\$226.63	\$253.02	\$253.68	\$281.79	\$308.84	\$335.89	\$362.93	\$380.10	\$397.34	\$414.57	\$431.81	\$449.04	\$466.28	\$483.52
52	to	\$234.74	\$262.25	\$263.76	\$293.03	\$322.06	\$351.08	\$380.10	\$397.34	\$414.57	\$431.81	\$449.04	\$466.28	\$483.52	\$500.76
56	to	\$242.91	\$271.53	\$273.91	\$304.33	\$335.34	\$366.34	\$397.34	\$414.57	\$431.81	\$449.04	\$466.28	\$483.52	\$500.76	\$518.00
60	to	\$255.24	\$285.57	\$289.21	\$321.39	\$355.36	\$389.33	\$423.30	\$439.08	\$453.18	\$467.28	\$481.38	\$495.48	\$509.58	\$523.68
66	to	\$284.99	\$319.08	\$324.31	\$360.43	\$399.76	\$439.08	\$478.40	\$496.16	\$513.84	\$531.52	\$549.20	\$566.88	\$584.56	\$602.24
72	to	\$298.42	\$334.33	\$340.90	\$378.90	\$421.39	\$463.87	\$506.35	\$548.83	\$591.31	\$633.79	\$676.27	\$718.75	\$761.23	\$803.71
78	to	\$321.06	\$359.95	\$368.82	\$409.90	\$457.66	\$505.42	\$553.18	\$600.94	\$648.70	\$696.46	\$744.22	\$791.98	\$839.74	\$887.50
88	to	\$365.01	\$409.43	\$421.26	\$468.12	\$524.38	\$580.63	\$636.88	\$693.13	\$749.38	\$805.63	\$861.88	\$918.13	\$974.38	\$1030.63
98	to	\$389.99	\$437.60	\$451.84	\$502.02	\$563.88	\$625.74	\$687.59	\$749.44	\$811.29	\$873.14	\$934.99	\$996.84	\$1058.69	\$1120.54
108	to	\$420.58	\$472.05	\$489.17	\$543.36	\$611.95	\$680.54	\$749.13	\$817.72	\$886.31	\$954.90	\$1023.49	\$1092.08	\$1160.67	\$1229.26

Bio Comfort® foam fill pricing applies to Standard and Premium Indoor fill styles. For up-to-date pricing, please visit www.DesignerCustomSource.com.

Suggested Retail Labor for

Bench Cushions with Bio Comfort® Foam Fill

Zippers / Ties / Single Cording / Double Cording

PRICING

Depth		48"–59 1/2"													
Thickness (Measured in Inches)		2	2	3	3	4	4	5	5	6	6	7	7	8	8
Width		SGL CRD	DBL CRD	SGL CRD	DBL CRD	SGL CRD	DBL CRD	SGL CRD	DBL CRD	SGL CRD	DBL CRD	SGL CRD	DBL CRD	SGL CRD	DBL CRD
26	to 28	\$178.19	\$197.58	\$193.57	\$214.40	\$229.77	\$245.15	\$260.53	\$323.47	\$341.50					
28	to 32	\$185.97	\$206.39	\$203.36	\$225.25	\$242.63	\$260.02	\$277.41	\$345.62	\$366.01					
32	to 36	\$193.80	\$215.26	\$213.20	\$236.15	\$255.55	\$274.95	\$294.34	\$367.84	\$390.58					
36	to 40	\$201.68	\$224.18	\$223.09	\$247.11	\$268.52	\$289.93	\$311.34	\$390.12	\$415.22					
40	to 44	\$209.61	\$233.15	\$233.03	\$258.13	\$281.55	\$304.97	\$328.39	\$412.47	\$439.93					
44	to 48	\$232.61	\$258.88	\$259.80	\$287.76	\$314.95	\$342.14	\$369.33	\$460.47	\$492.05					
48	to 52	\$241.21	\$268.59	\$270.55	\$299.66	\$329.01	\$358.35	\$387.69	\$484.29	\$518.37					
52	to 56	\$249.87	\$278.37	\$281.36	\$311.63	\$343.12	\$374.62	\$406.11	\$508.19	\$544.76					
56	to 60	\$258.59	\$288.21	\$292.24	\$323.66	\$357.31	\$390.95	\$424.60	\$532.16	\$571.24					
60	to 66	\$271.76	\$303.08	\$308.64	\$341.81	\$378.69	\$415.57	\$452.45	\$568.25	\$611.08					
66	to 72	\$303.47	\$338.62	\$346.17	\$383.35	\$426.05	\$468.75	\$511.45	\$638.12	\$687.29					
72	to 78	\$317.80	\$354.77	\$363.94	\$403.01	\$449.15	\$495.30	\$541.44	\$676.61	\$729.75					
78	to 88	\$341.97	\$381.92	\$393.86	\$436.00	\$487.89	\$539.77	\$591.66	\$741.06	\$800.80					
88	to 98	\$388.83	\$434.37	\$449.95	\$497.94	\$559.07	\$620.20	\$681.33	\$806.09	\$872.46					
98	to 108	\$415.48	\$464.22	\$482.71	\$534.02	\$601.24	\$668.47	\$735.70	\$871.75	\$944.75					
108	to 120	\$448.12	\$500.71	\$522.68	\$578.00	\$652.55	\$727.11	\$801.67	\$951.34	\$1,032.29					

Bio Comfort® foam fill pricing applies to Standard and Premium Indoor fill styles. For up-to-date pricing, please visit www.DesignerCustomSource.com.

Suggested Retail Labor for

Bench Cushions with Bio Comfort® Foam Fill

Zippers / Ties / Single Cording / Double Cording

PRICING

Depth		60"–79 1/2"									
Thickness (Measured in Inches)		2	2	3	3	4	5	6	7	8	
Width		SGL CRD	DBL CRD	SGL CRD	DBL CRD	SGL CRD	DBL CRD	SGL CRD	DBL CRD	SGL CRD	DBL CRD
26	to 28	\$210.10	\$232.24	\$228.95	\$252.53	\$271.38	\$290.23	\$309.09	\$384.48	\$406.58	
28	to 32	\$219.36	\$242.54	\$240.71	\$265.36	\$286.72	\$308.07	\$329.43	\$411.27	\$436.30	
32	to 36	\$228.68	\$252.90	\$252.54	\$278.25	\$302.12	\$325.98	\$349.84	\$438.13	\$466.11	
36	to 40	\$238.07	\$263.32	\$264.43	\$291.21	\$317.58	\$343.95	\$370.31	\$465.07	\$495.99	
40	to 44	\$247.51	\$273.81	\$276.39	\$304.23	\$333.11	\$361.98	\$390.85	\$492.09	\$525.95	
44	to 48	\$274.75	\$303.97	\$308.29	\$339.21	\$372.75	\$406.30	\$439.84	\$549.74	\$588.69	
48	to 52	\$284.99	\$315.32	\$321.21	\$353.27	\$389.50	\$425.72	\$461.95	\$578.52	\$620.59	
52	to 56	\$295.29	\$326.75	\$334.20	\$367.41	\$406.32	\$445.23	\$484.13	\$607.40	\$652.58	
56	to 60	\$305.67	\$338.24	\$347.26	\$381.63	\$423.22	\$464.81	\$506.39	\$636.37	\$684.66	
60	to 66	\$321.35	\$355.61	\$366.96	\$403.08	\$448.69	\$494.30	\$539.91	\$679.96	\$732.93	
66	to 72	\$358.94	\$397.23	\$411.78	\$452.10	\$504.94	\$557.78	\$610.62	\$763.99	\$824.83	
72	to 78	\$375.99	\$416.10	\$433.12	\$475.32	\$532.45	\$589.57	\$646.70	\$810.46	\$876.25	
78	to 88	\$404.74	\$447.82	\$469.01	\$514.29	\$578.57	\$642.84	\$707.11	\$888.27	\$962.28	
88	to 98	\$460.33	\$509.20	\$536.09	\$587.41	\$663.16	\$738.92	\$814.67	\$966.75	\$1,049.00	
98	to 108	\$492.01	\$544.07	\$575.35	\$629.99	\$713.34	\$796.69	\$880.03	\$1,045.96	\$1,136.45	
108	to 120	\$530.78	\$586.71	\$623.25	\$681.89	\$774.36	\$866.83	\$959.29	\$1,141.91	\$1,242.30	

Bio Comfort® foam fill pricing applies to Standard and Premium Indoor fill styles. For up-to-date pricing, please visit www.DesignerCustomSource.com.

Suggested Retail Labor for

Bench Cushions with Bio Comfort® Foam Fill

Zippers / Ties / Single Cording / Double Cording

PRICING

Depth		80"													
Thickness (Measured in Inches)		2	2	3	3	4	4	5	5	6	6	7	7	8	8
Width		SGL CRD	DBL CRD	SGL CRD	DBL CRD	SGL CRD	DBL CRD	SGL CRD	DBL CRD	SGL CRD	DBL CRD	SGL CRD	DBL CRD	SGL CRD	DBL CRD
26	to 28	\$263.26	\$290.01	\$287.91	\$316.09	\$340.73	\$365.37	\$390.02	\$486.15	\$515.05					
28	to 32	\$275.00	\$302.78	\$302.97	\$332.22	\$360.19	\$388.16	\$416.13	\$520.67	\$553.47					
32	to 36	\$286.82	\$315.63	\$318.12	\$348.43	\$379.73	\$411.03	\$442.33	\$555.29	\$591.98					
36	to 40	\$298.71	\$328.56	\$333.34	\$364.71	\$399.34	\$433.97	\$468.60	\$589.99	\$630.59					
40	to 44	\$310.68	\$341.57	\$348.64	\$381.08	\$419.04	\$457.00	\$494.96	\$624.80	\$669.30					
44	to 48	\$344.99	\$379.12	\$389.12	\$424.95	\$469.09	\$513.22	\$557.36	\$698.51	\$749.77					
48	to 52	\$357.95	\$393.20	\$405.65	\$442.63	\$490.32	\$538.02	\$585.72	\$735.58	\$790.97					
52	to 56	\$371.00	\$407.37	\$422.26	\$460.39	\$511.65	\$562.91	\$614.17	\$772.75	\$832.28					
56	to 60	\$384.15	\$421.63	\$438.97	\$478.25	\$533.07	\$587.89	\$642.71	\$810.04	\$873.70					
60	to 66	\$403.99	\$443.17	\$464.16	\$505.19	\$565.35	\$625.52	\$685.68	\$866.15	\$936.01					
66	to 72	\$451.40	\$494.93	\$521.14	\$566.69	\$636.43	\$706.17	\$775.90	\$973.77	\$1,054.07					
72	to 78	\$472.98	\$518.32	\$548.41	\$595.84	\$671.27	\$746.70	\$822.13	\$1,033.55	\$1,120.41					
78	to 88	\$509.35	\$557.66	\$594.27	\$644.78	\$729.70	\$814.62	\$899.54	\$1,133.61	\$1,231.40					
88	to 98	\$579.51	\$633.93	\$679.64	\$736.51	\$836.65	\$936.78	\$1,036.92	\$1,234.52	\$1,343.23					
98	to 108	\$619.55	\$677.16	\$729.76	\$789.95	\$900.16	\$1,010.37	\$1,120.58	\$1,336.29	\$1,455.95					
108	to 120	\$668.55	\$730.02	\$790.86	\$855.06	\$977.37	\$1,099.68	\$1,221.99	\$1,459.53	\$1,592.33					

Bio Comfort® foam fill pricing applies to Standard and Premium Indoor fill styles. For up-to-date pricing, please visit www.DesignerCustomSource.com.

Suggested Retail Labor for

Bench Cushions with CumuPlush Fill

Zipper / Ties / Knife and Boxed Edges

PRICING

Depth		17"–19 1/2"										
Thickness (Measured in Inches)		2	2	3	3	4	5	6	7	8		
Width		KNIFE	BOXED	KNIFE	BOXED	BOXED	BOXED	BOXED	BOXED	BOXED		
26	to 28	\$86.30	\$90.61	\$90.44	\$96.19	\$100.33	\$104.48	\$108.62	\$132.21	\$137.07		
28	to 32	\$89.00	\$93.40	\$93.56	\$99.42	\$103.98	\$108.54	\$113.09	\$137.93	\$143.28		
32	to 36	\$91.74	\$96.22	\$96.71	\$102.69	\$107.66	\$112.63	\$117.60	\$143.70	\$149.53		
36	to 40	\$94.50	\$99.08	\$99.89	\$105.98	\$111.37	\$116.75	\$122.14	\$149.51	\$155.82		
40	to 44	\$97.30	\$101.96	\$103.10	\$109.32	\$115.11	\$120.91	\$126.71	\$155.35	\$162.15		
44	to 48	\$107.03	\$112.12	\$113.67	\$120.45	\$127.09	\$133.74	\$140.38	\$170.73	\$178.44		
48	to 52	\$110.09	\$115.28	\$117.17	\$124.09	\$131.17	\$138.26	\$145.34	\$177.01	\$185.24		
52	to 56	\$113.18	\$118.47	\$120.71	\$127.76	\$135.29	\$142.82	\$150.35	\$183.34	\$192.09		
56	to 60	\$116.30	\$121.70	\$124.28	\$131.47	\$139.45	\$147.42	\$155.40	\$189.72	\$198.99		
60	to 66	\$121.05	\$126.61	\$129.69	\$137.10	\$145.75	\$154.39	\$163.03	\$199.37	\$209.40		
66	to 72	\$133.99	\$140.09	\$143.91	\$152.03	\$161.95	\$171.87	\$181.78	\$220.74	\$232.16		
72	to 78	\$139.22	\$145.50	\$149.85	\$158.22	\$168.85	\$179.48	\$190.11	\$231.16	\$243.40		
78	to 88	\$148.09	\$154.68	\$159.91	\$168.70	\$180.53	\$192.36	\$204.18	\$248.74	\$262.36		
88	to 98	\$163.89	\$171.11	\$177.47	\$187.09	\$200.67	\$214.25	\$227.83	\$266.68	\$281.68		
98	to 108	\$173.71	\$181.28	\$188.54	\$198.64	\$213.48	\$228.32	\$243.16	\$285.00	\$301.39		
108	to 120	\$185.85	\$193.88	\$202.20	\$212.91	\$229.26	\$245.62	\$261.97	\$307.46	\$325.52		

CumuPlush fill pricing applies to Standard Outdoor, Direct Fill and Plush fill styles. For up-to-date pricing, please visit www.DesignerCustomSource.com.

Suggested Retail Labor for

Bench Cushions with CumuPlush Fill

Zippers / Ties / Knife and Boxed Edges

PRICING

Depth		20" - 22 1/2"							
Thickness (Measured in Inches)		2	3	4	5	6	7	8	
Width		KNIFE	KNIFE	BOXED	BOXED	BOXED	BOXED	BOXED	
26	to 28	\$93.21	\$97.83	\$103.57	\$108.19	\$112.80	\$117.42	\$143.08	\$148.49
28	to 32	\$96.24	\$101.34	\$107.20	\$112.29	\$117.39	\$122.48	\$149.57	\$155.55
32	to 36	\$99.30	\$104.88	\$110.86	\$116.43	\$122.01	\$127.58	\$156.11	\$162.65
36	to 40	\$102.40	\$108.45	\$114.55	\$120.61	\$126.66	\$132.71	\$162.70	\$169.79
40	to 44	\$105.53	\$112.06	\$118.28	\$124.82	\$131.35	\$137.89	\$169.32	\$176.99
44	to 48	\$116.18	\$123.68	\$130.46	\$137.96	\$145.47	\$152.97	\$186.35	\$195.06
48	to 52	\$119.60	\$127.61	\$134.53	\$142.55	\$150.56	\$158.58	\$193.46	\$202.77
52	to 56	\$123.05	\$131.58	\$138.64	\$147.17	\$155.70	\$164.23	\$200.63	\$210.54
56	to 60	\$126.54	\$135.59	\$142.78	\$151.83	\$160.88	\$169.93	\$207.85	\$218.35
60	to 66	\$131.83	\$141.66	\$149.07	\$158.89	\$168.72	\$178.54	\$218.75	\$230.16
66	to 72	\$146.07	\$157.35	\$165.48	\$176.77	\$188.05	\$199.34	\$242.54	\$255.53
72	to 78	\$151.89	\$164.01	\$172.38	\$184.49	\$196.61	\$208.73	\$254.30	\$268.25
78	to 88	\$161.77	\$175.27	\$184.06	\$197.56	\$211.06	\$224.56	\$274.13	\$289.68
88	to 98	\$182.35	\$198.15	\$207.94	\$223.73	\$239.52	\$255.32	\$294.35	\$311.50
98	to 108	\$193.45	\$210.73	\$221.00	\$238.28	\$255.55	\$272.83	\$314.97	\$333.73
108	to 120	\$207.17	\$226.23	\$237.13	\$256.18	\$275.24	\$294.30	\$340.22	\$360.92

CumuPlush fill pricing applies to Standard Outdoor, Direct Fill and Plush fill styles. For up-to-date pricing, please visit www.DesignerCustomSource.com.

Suggested Retail Labor for

Bench Cushions with CumuPlush Fill

Zippers / Ties / Knife and Boxed Edges

PRICING

Depth		23" - 25 1/2"							
Thickness (Measured in Inches)		2	3	4	5	6	7	8	
Width		KNIFE	BOXED	KNIFE	BOXED	KNIFE	BOXED	KNIFE	BOXED
26	to	\$100.12	\$104.43	\$110.96	\$116.04	\$121.13	\$126.22	\$153.94	\$159.91
28	to	\$103.48	\$107.87	\$114.97	\$120.61	\$126.24	\$131.87	\$161.21	\$167.82
32	to	\$106.87	\$111.35	\$119.03	\$125.21	\$131.38	\$137.56	\$168.53	\$175.77
36	to	\$110.29	\$114.87	\$123.12	\$129.84	\$136.57	\$143.29	\$175.89	\$183.77
40	to	\$113.75	\$118.42	\$127.24	\$134.52	\$141.79	\$149.06	\$183.29	\$191.82
44	to	\$125.33	\$130.42	\$140.47	\$148.83	\$157.20	\$165.56	\$201.97	\$211.68
48	to	\$129.11	\$134.29	\$144.97	\$153.92	\$162.86	\$171.81	\$209.91	\$220.30
52	to	\$132.92	\$138.21	\$149.51	\$159.04	\$168.58	\$178.11	\$217.91	\$228.99
56	to	\$136.78	\$142.17	\$154.09	\$164.22	\$174.34	\$184.46	\$225.97	\$237.72
60	to	\$142.62	\$148.18	\$161.04	\$172.04	\$183.05	\$194.05	\$238.13	\$250.91
66	to	\$158.14	\$164.24	\$178.92	\$191.58	\$204.24	\$216.89	\$264.33	\$278.91
72	to	\$164.57	\$170.84	\$186.54	\$200.14	\$213.74	\$227.34	\$277.44	\$293.10
78	to	\$175.45	\$182.04	\$199.42	\$214.59	\$229.77	\$244.94	\$299.53	\$317.00
88	to	\$197.96	\$205.30	\$225.52	\$243.29	\$261.06	\$278.83	\$322.02	\$341.32
98	to	\$210.17	\$217.88	\$239.90	\$259.35	\$278.81	\$298.26	\$344.95	\$366.07
108	to	\$225.25	\$233.42	\$257.63	\$279.11	\$300.58	\$322.06	\$372.99	\$396.31

CumuPlush fill pricing applies to Standard Outdoor, Direct Fill and Plush fill styles. For up-to-date pricing, please visit www.DesignerCustomSource.com.

Suggested Retail Labor for

Bench Cushions with CumuPlush Fill

Zippers / Ties / Knife and Boxed Edges

PRICING

Depth		26" - 28 1/2"									
Thickness (Measured in Inches)		2	3	4	5	6	7	8			
Width		KNIFE	KNIFE	BOXED	BOXED	BOXED	BOXED	BOXED	BOXED	BOXED	BOXED
26	to 28	\$107.04	\$112.60	\$118.34	\$123.90	\$129.46	\$135.02	\$164.81	\$171.33		
28	to 32	\$110.72	\$116.89	\$122.75	\$128.92	\$135.09	\$141.26	\$172.85	\$180.09		
32	to 36	\$114.44	\$121.22	\$127.20	\$133.98	\$140.76	\$147.55	\$180.94	\$188.89		
36	to 40	\$118.19	\$125.59	\$131.68	\$139.08	\$146.48	\$153.87	\$189.08	\$197.75		
40	to 44	\$121.98	\$129.99	\$136.21	\$144.22	\$152.23	\$160.24	\$197.26	\$206.65		
44	to 48	\$134.48	\$143.70	\$150.48	\$159.70	\$168.93	\$178.15	\$217.59	\$228.30		
48	to 52	\$138.62	\$148.49	\$155.41	\$165.29	\$175.17	\$185.05	\$226.36	\$237.84		
52	to 56	\$142.79	\$153.33	\$160.38	\$170.92	\$181.46	\$191.99	\$235.20	\$247.43		
56	to 60	\$147.01	\$158.21	\$165.40	\$176.60	\$187.79	\$198.99	\$244.09	\$257.09		
60	to 66	\$153.40	\$165.59	\$173.00	\$185.19	\$197.37	\$209.56	\$257.51	\$271.66		
66	to 72	\$170.22	\$184.24	\$192.37	\$206.40	\$220.42	\$234.45	\$286.13	\$302.28		
72	to 78	\$177.24	\$192.32	\$200.69	\$215.78	\$230.86	\$245.95	\$300.58	\$317.95		
78	to 88	\$189.14	\$205.99	\$214.77	\$231.62	\$248.47	\$265.32	\$324.93	\$344.33		
88	to 98	\$213.56	\$233.31	\$243.10	\$262.85	\$282.59	\$302.34	\$349.70	\$371.14		
98	to 108	\$226.89	\$248.52	\$258.80	\$280.43	\$302.06	\$323.69	\$374.92	\$398.41		
108	to 120	\$243.34	\$267.23	\$278.13	\$302.03	\$325.92	\$349.82	\$405.76	\$431.70		

CumuPlush fill pricing applies to Standard Outdoor, Direct Fill and Plush fill styles. For up-to-date pricing, please visit www.DesignerCustomSource.com.

Suggested Retail Labor for

Bench Cushions with CumuPlush Fill

Zippers / Ties / Knife and Boxed Edges

PRICING

Depth		29"–31 1/2"							
Thickness (Measured in Inches)		2	3	4	5	6	7	8	
Width		KNIFE	KNIFE	BOXED	BOXED	BOXED	BOXED	BOXED	
26	to 28	\$113.95	\$119.98	\$125.73	\$131.76	\$137.79	\$143.81	\$175.68	\$182.75
28	to 32	\$117.96	\$124.67	\$130.53	\$137.23	\$143.94	\$150.65	\$184.49	\$192.36
32	to 36	\$122.00	\$129.39	\$135.37	\$142.75	\$150.14	\$157.53	\$193.35	\$202.01
36	to 40	\$126.08	\$134.15	\$140.25	\$148.32	\$156.38	\$164.45	\$202.27	\$211.73
40	to 44	\$130.20	\$138.95	\$145.17	\$153.92	\$162.67	\$171.42	\$211.23	\$221.49
44	to 48	\$143.63	\$153.71	\$160.49	\$170.57	\$180.66	\$190.74	\$233.21	\$244.91
48	to 52	\$148.13	\$158.94	\$165.85	\$176.66	\$187.47	\$198.28	\$242.82	\$255.37
52	to 56	\$152.66	\$164.20	\$171.26	\$182.80	\$194.34	\$205.88	\$252.48	\$265.88
56	to 60	\$157.25	\$169.52	\$176.71	\$188.98	\$201.25	\$213.52	\$262.21	\$276.46
60	to 66	\$164.19	\$177.56	\$184.97	\$198.33	\$211.70	\$225.07	\$276.89	\$292.41
66	to 72	\$182.29	\$197.69	\$205.81	\$221.21	\$236.61	\$252.01	\$307.92	\$325.65
72	to 78	\$189.91	\$206.48	\$214.85	\$231.42	\$247.99	\$264.56	\$323.72	\$342.80
78	to 88	\$202.82	\$221.34	\$230.13	\$248.66	\$267.18	\$285.70	\$350.32	\$371.65
88	to 98	\$229.17	\$250.89	\$260.68	\$282.40	\$304.13	\$325.85	\$377.37	\$400.96
98	to 108	\$243.61	\$267.42	\$277.69	\$301.50	\$325.31	\$349.12	\$404.90	\$430.75
108	to 120	\$261.42	\$287.74	\$298.63	\$324.95	\$351.27	\$377.58	\$438.52	\$467.10

CumuPlush fill pricing applies to Standard Outdoor, Direct Fill and Plush fill styles. For up-to-date pricing, please visit www.DesignerCustomSource.com.

Suggested Retail Labor for

Bench Cushions with CumuPlush Fill

Zippers / Ties / Knife and Boxed Edges

PRICING

Depth		32" - 35 1/2"							
Thickness (Measured in Inches)		2	3	4	5	6	7	8	
Width		KNIFE	KNIFE	BOXED	BOXED	BOXED	BOXED	BOXED	
26	to 28	\$120.87	\$127.37	\$133.11	\$139.61	\$146.11	\$152.61	\$186.55	\$194.17
28	to 32	\$125.20	\$132.44	\$138.30	\$145.55	\$152.79	\$160.04	\$196.13	\$204.63
32	to 36	\$129.57	\$137.56	\$143.54	\$151.53	\$159.52	\$167.51	\$205.77	\$215.14
36	to 40	\$133.98	\$142.72	\$148.81	\$157.55	\$166.29	\$175.03	\$215.46	\$225.70
40	to 44	\$138.43	\$147.92	\$154.14	\$163.62	\$173.11	\$182.60	\$225.20	\$236.32
44	to 48	\$152.78	\$163.72	\$170.50	\$181.44	\$192.39	\$203.33	\$248.83	\$261.53
48	to 52	\$157.63	\$169.38	\$176.29	\$188.03	\$199.77	\$211.52	\$259.27	\$272.90
52	to 56	\$162.53	\$175.08	\$182.13	\$194.67	\$207.21	\$219.76	\$269.77	\$284.33
56	to 60	\$167.48	\$180.82	\$188.02	\$201.36	\$214.71	\$228.05	\$280.33	\$295.83
60	to 66	\$174.98	\$189.52	\$196.93	\$211.48	\$226.03	\$240.58	\$296.27	\$313.17
66	to 72	\$194.36	\$211.13	\$219.26	\$236.03	\$252.80	\$269.57	\$329.72	\$349.03
72	to 78	\$202.59	\$220.64	\$229.01	\$247.06	\$265.12	\$283.17	\$346.86	\$367.65
78	to 88	\$216.50	\$236.70	\$245.49	\$265.69	\$285.88	\$306.08	\$375.72	\$398.98
88	to 98	\$244.77	\$268.47	\$278.26	\$301.96	\$325.66	\$349.37	\$405.04	\$430.78
98	to 108	\$260.32	\$286.31	\$296.59	\$322.58	\$348.56	\$374.55	\$434.87	\$463.09
108	to 120	\$279.50	\$308.24	\$319.13	\$347.87	\$376.61	\$405.34	\$471.29	\$502.49

CumuPlush fill pricing applies to Standard Outdoor, Direct Fill and Plush fill styles. For up-to-date pricing, please visit www.DesignerCustomSource.com.

Suggested Retail Labor for

Bench Cushions with CumuPlush Fill

Zippers / Ties / Knife and Boxed Edges

PRICING

Depth		36"–39 1/2"							
Thickness (Measured in Inches)		2	3	4	5	6	7	8	
Width		KNIFE	KNIFE	BOXED	BOXED	BOXED	BOXED	BOXED	
26	to 28	\$130.08	\$137.21	\$150.09	\$157.22	\$164.34	\$201.04	\$209.39	
28	to 32	\$134.85	\$142.81	\$156.63	\$164.60	\$172.56	\$211.65	\$220.98	
32	to 36	\$139.65	\$148.45	\$163.23	\$172.03	\$180.82	\$222.32	\$232.63	
36	to 40	\$144.50	\$154.14	\$169.87	\$179.50	\$189.14	\$233.04	\$244.34	
40	to 44	\$149.40	\$159.87	\$176.56	\$187.03	\$197.50	\$243.83	\$256.10	
44	to 48	\$164.98	\$177.07	\$195.94	\$208.03	\$220.11	\$269.65	\$283.69	
48	to 52	\$170.31	\$183.30	\$203.20	\$216.18	\$229.16	\$281.20	\$296.28	
52	to 56	\$175.69	\$189.57	\$210.51	\$224.39	\$238.26	\$292.81	\$308.93	
56	to 60	\$181.13	\$195.90	\$217.87	\$232.65	\$247.43	\$304.49	\$321.65	
60	to 66	\$189.36	\$205.48	\$229.01	\$245.13	\$261.26	\$322.12	\$340.84	
66	to 72	\$210.46	\$229.06	\$255.78	\$274.38	\$292.97	\$358.78	\$380.19	
72	to 78	\$219.48	\$239.52	\$267.92	\$287.95	\$307.99	\$377.72	\$400.79	
78	to 88	\$234.75	\$257.18	\$288.40	\$310.83	\$333.26	\$409.58	\$435.41	
88	to 98	\$265.58	\$291.91	\$328.04	\$354.38	\$380.71	\$441.94	\$470.54	
98	to 108	\$282.61	\$311.51	\$350.67	\$379.57	\$408.46	\$474.84	\$506.21	
108	to 120	\$303.61	\$335.57	\$378.43	\$410.39	\$442.36	\$514.98	\$549.68	

CumuPlush fill pricing applies to Standard Outdoor, Direct Fill and Plush fill styles. For up-to-date pricing, please visit www.DesignerCustomSource.com.

Suggested Retail Labor for

Bench Cushions with CumuPlush Fill

Zippers / Ties / Knife and Boxed Edges

PRICING

Depth		40"–43 1/2"							
Thickness (Measured in Inches)		2	3	4	5	6	7	8	
Width		KNIFE	KNIFE	BOXED	BOXED	BOXED	BOXED	BOXED	
26	to	\$139.30	\$147.06	\$160.56	\$168.32	\$176.07	\$215.53	\$224.62	
28	to	\$144.50	\$153.18	\$167.72	\$176.40	\$185.08	\$227.17	\$237.34	
32	to	\$149.74	\$159.35	\$174.93	\$184.53	\$194.14	\$238.87	\$250.13	
36	to	\$155.03	\$165.56	\$182.19	\$192.71	\$203.24	\$250.63	\$262.97	
40	to	\$160.37	\$171.82	\$189.49	\$200.95	\$212.40	\$262.45	\$275.88	
44	to	\$177.18	\$190.42	\$210.43	\$223.67	\$236.90	\$290.48	\$305.85	
48	to	\$182.99	\$197.22	\$218.36	\$232.58	\$246.81	\$303.13	\$319.65	
52	to	\$188.86	\$204.07	\$226.34	\$241.56	\$256.77	\$315.86	\$333.53	
56	to	\$194.78	\$210.98	\$234.39	\$250.59	\$266.80	\$328.65	\$347.48	
60	to	\$203.74	\$221.43	\$246.54	\$264.24	\$281.93	\$347.96	\$368.51	
66	to	\$226.56	\$246.98	\$275.54	\$295.96	\$316.38	\$387.84	\$411.36	
72	to	\$236.38	\$258.39	\$288.78	\$310.79	\$332.80	\$408.57	\$433.92	
78	to	\$252.99	\$277.65	\$311.10	\$335.77	\$360.43	\$443.44	\$471.84	
88	to	\$286.38	\$315.35	\$354.12	\$383.09	\$412.06	\$478.84	\$510.30	
98	to	\$304.90	\$336.70	\$378.77	\$410.57	\$442.36	\$514.80	\$549.33	
108	to	\$327.72	\$362.91	\$408.99	\$444.18	\$479.37	\$558.67	\$596.87	

CumuPlush fill pricing applies to Standard Outdoor, Direct Fill and Plush fill styles. For up-to-date pricing, please visit www.DesignerCustomSource.com.

Suggested Retail Labor for

Bench Cushions with CumuPlush Fill

Zippers / Ties / Knife and Boxed Edges

PRICING

Depth		44"–47 1/2"							
Thickness (Measured in Inches)		2	3	4	5	6	7	8	
Width		KNIFE	KNIFE	BOXED	BOXED	BOXED	BOXED	BOXED	
26	to 28	\$148.52	\$156.91	\$162.65	\$171.04	\$179.42	\$187.81	\$230.02	\$239.85
28	to 32	\$154.15	\$163.55	\$169.41	\$178.81	\$188.20	\$197.60	\$242.69	\$253.70
32	to 36	\$159.83	\$170.24	\$176.22	\$186.63	\$197.04	\$207.45	\$255.42	\$267.62
36	to 40	\$165.56	\$176.98	\$183.08	\$194.50	\$205.92	\$217.35	\$268.22	\$281.61
40	to 44	\$171.34	\$183.77	\$189.99	\$202.43	\$214.87	\$227.31	\$281.08	\$295.66
44	to 48	\$189.38	\$203.76	\$210.54	\$224.93	\$239.31	\$253.69	\$311.30	\$328.00
48	to 52	\$195.67	\$211.14	\$218.05	\$233.52	\$248.99	\$264.45	\$325.07	\$343.03
52	to 56	\$202.02	\$218.57	\$225.62	\$242.18	\$258.73	\$275.28	\$338.90	\$358.13
56	to 60	\$208.42	\$226.06	\$233.26	\$250.90	\$268.54	\$286.17	\$352.82	\$373.30
60	to 66	\$218.12	\$237.39	\$244.80	\$264.07	\$283.34	\$302.61	\$373.80	\$396.18
66	to 72	\$242.66	\$264.91	\$273.04	\$295.29	\$317.54	\$339.79	\$416.90	\$442.52
72	to 78	\$253.28	\$277.27	\$285.64	\$309.63	\$333.62	\$357.62	\$439.43	\$467.05
78	to 88	\$271.23	\$298.13	\$306.92	\$333.81	\$360.71	\$387.60	\$477.30	\$508.27
88	to 98	\$307.19	\$338.80	\$348.58	\$380.19	\$411.80	\$443.41	\$515.74	\$550.06
98	to 108	\$327.19	\$361.89	\$372.17	\$406.87	\$441.57	\$476.27	\$554.77	\$592.44
108	to 120	\$351.83	\$390.24	\$401.13	\$439.55	\$477.97	\$516.38	\$602.35	\$644.06

CumuPlush fill pricing applies to Standard Outdoor, Direct Fill and Plush fill styles. For up-to-date pricing, please visit www.DesignerCustomSource.com.

Suggested Retail Labor for

Bench Cushions with CumuPlush Fill

Zippers / Ties / Knife and Boxed Edges

PRICING

Depth		48"–59 1/2"							
Thickness (Measured in Inches)		2	3	4	5	6	7	8	
Width		KNIFE	KNIFE	BOXED	BOXED	BOXED	BOXED	BOXED	
26	to	\$157.74	\$166.75	\$172.50	\$181.51	\$190.52	\$199.54	\$244.51	\$255.07
28	to	\$163.80	\$173.92	\$179.78	\$189.89	\$200.01	\$210.12	\$258.20	\$270.06
32	to	\$169.92	\$181.13	\$187.11	\$198.33	\$209.54	\$220.76	\$271.97	\$285.12
36	to	\$176.08	\$188.40	\$194.50	\$206.82	\$219.14	\$231.45	\$285.80	\$300.25
40	to	\$182.30	\$195.72	\$201.94	\$215.37	\$228.79	\$242.21	\$299.71	\$315.44
44	to	\$201.58	\$217.11	\$223.89	\$239.42	\$254.95	\$270.47	\$332.13	\$350.16
48	to	\$208.35	\$225.06	\$231.97	\$248.68	\$265.39	\$282.10	\$347.00	\$366.40
52	to	\$215.18	\$233.07	\$240.12	\$258.01	\$275.90	\$293.79	\$361.95	\$382.72
56	to	\$222.07	\$241.14	\$248.34	\$267.41	\$286.48	\$305.55	\$376.98	\$399.12
60	to	\$232.50	\$253.34	\$260.76	\$281.60	\$302.45	\$323.29	\$399.64	\$423.65
66	to	\$258.76	\$282.84	\$290.96	\$315.04	\$339.12	\$363.20	\$445.96	\$473.69
72	to	\$270.17	\$296.15	\$304.52	\$330.49	\$356.46	\$382.43	\$470.28	\$500.19
78	to	\$289.48	\$318.60	\$327.39	\$356.52	\$385.65	\$414.78	\$511.16	\$544.70
88	to	\$327.99	\$362.24	\$372.02	\$406.27	\$440.52	\$474.76	\$552.64	\$589.82
98	to	\$349.48	\$387.09	\$397.37	\$434.97	\$472.57	\$510.18	\$594.74	\$635.56
108	to	\$375.93	\$417.58	\$428.47	\$470.11	\$511.76	\$553.40	\$646.04	\$691.26

CumuPlush fill pricing applies to Standard Outdoor, Direct Fill and Plush fill styles. For up-to-date pricing, please visit www.DesignerCustomSource.com.

Suggested Retail Labor for

Bench Cushions with CumuPlush Fill

Zippers / Ties / Knife and Boxed Edges

PRICING

Depth		60"–79 1/2"							
Thickness (Measured in Inches)		2	3	4	5	6	7	8	
Width		KNIFE	KNIFE	BOXED	BOXED	BOXED	BOXED	BOXED	
26	to 28	\$185.40	\$196.29	\$202.04	\$212.94	\$223.83	\$234.73	\$287.98	\$300.75
28	to 32	\$192.76	\$205.02	\$210.88	\$223.15	\$235.41	\$247.68	\$304.76	\$319.14
32	to 36	\$200.18	\$213.81	\$219.79	\$233.42	\$247.06	\$260.69	\$321.62	\$337.61
36	to 40	\$207.66	\$222.67	\$228.76	\$243.77	\$258.77	\$273.77	\$338.56	\$356.15
40	to 44	\$215.21	\$231.58	\$237.80	\$254.17	\$270.55	\$286.92	\$355.58	\$374.78
44	to 48	\$238.18	\$257.15	\$263.93	\$282.90	\$301.87	\$320.83	\$394.61	\$416.63
48	to 52	\$246.39	\$266.82	\$273.74	\$294.17	\$314.60	\$335.04	\$412.80	\$436.53
52	to 56	\$254.66	\$276.56	\$283.62	\$305.52	\$327.41	\$349.31	\$431.09	\$456.52
56	to 60	\$263.01	\$286.38	\$293.57	\$316.94	\$340.30	\$363.67	\$449.46	\$476.60
60	to 66	\$275.64	\$301.21	\$308.62	\$334.19	\$359.76	\$385.33	\$477.17	\$506.66
66	to 72	\$307.05	\$336.62	\$344.74	\$374.30	\$403.87	\$433.43	\$533.14	\$567.19
72	to 78	\$320.87	\$352.78	\$361.15	\$393.06	\$424.97	\$456.88	\$562.84	\$599.59
78	to 88	\$344.21	\$380.03	\$388.82	\$424.65	\$460.47	\$496.30	\$612.75	\$654.00
88	to 98	\$390.41	\$432.56	\$442.35	\$484.50	\$526.66	\$568.81	\$663.33	\$709.10
98	to 108	\$416.35	\$462.67	\$472.95	\$519.27	\$565.58	\$611.90	\$714.64	\$764.92
108	to 120	\$448.26	\$499.58	\$510.47	\$561.80	\$613.12	\$664.44	\$777.11	\$832.83

CumuPlush fill pricing applies to Standard Outdoor, Direct Fill and Plush fill styles. For up-to-date pricing, please visit www.DesignerCustomSource.com.

Suggested Retail Labor for

Bench Cushions with CumuPlush Fill

Zippers / Ties / Knife and Boxed Edges

PRICING

Depth		80"							
Thickness (Measured in Inches)		2	3	4	5	6	7	8	
Width		KNIFE	KNIFE	BOXED	BOXED	BOXED	BOXED	BOXED	
26	to 28	\$231.49	\$245.53	\$251.27	\$265.31	\$279.35	\$293.38	\$360.42	\$376.88
28	to 32	\$241.02	\$256.87	\$262.73	\$278.58	\$294.43	\$310.28	\$382.35	\$400.94
32	to 36	\$250.62	\$268.28	\$274.26	\$291.92	\$309.58	\$327.25	\$404.38	\$425.09
36	to 40	\$260.29	\$279.77	\$285.87	\$305.35	\$324.82	\$344.30	\$426.50	\$449.33
40	to 44	\$270.05	\$291.34	\$297.56	\$318.85	\$340.14	\$361.43	\$448.71	\$473.68
44	to 48	\$299.18	\$323.89	\$330.67	\$355.37	\$380.07	\$404.77	\$498.74	\$527.42
48	to 52	\$309.78	\$336.42	\$343.34	\$369.98	\$396.62	\$423.26	\$522.47	\$553.41
52	to 56	\$320.47	\$349.05	\$356.11	\$384.69	\$413.27	\$441.86	\$546.31	\$579.51
56	to 60	\$331.25	\$361.77	\$368.97	\$399.49	\$430.02	\$460.54	\$570.27	\$605.72
60	to 66	\$347.55	\$380.99	\$388.40	\$421.84	\$455.28	\$488.72	\$606.37	\$645.21
66	to 72	\$387.55	\$426.25	\$434.37	\$473.07	\$511.78	\$550.48	\$678.45	\$723.01
72	to 78	\$405.35	\$447.16	\$455.53	\$497.34	\$539.14	\$580.95	\$717.12	\$765.26
78	to 88	\$435.43	\$482.41	\$491.20	\$538.19	\$585.18	\$632.16	\$782.05	\$836.16
88	to 98	\$494.43	\$549.77	\$559.55	\$614.89	\$670.22	\$725.55	\$847.82	\$907.90
98	to 108	\$527.81	\$588.64	\$598.92	\$659.76	\$720.60	\$781.44	\$914.47	\$980.52
108	to 120	\$568.80	\$636.26	\$647.15	\$714.60	\$782.05	\$849.51	\$995.55	\$1,068.79

CumuPlush fill pricing applies to Standard Outdoor, Direct Fill and Plush fill styles. For up-to-date pricing, please visit www.DesignerCustomSource.com.

Suggested Retail Labor for

Bench Cushions with CumuPlush Fill

Zippers / Ties / Single Cording / Double Cording

PRICING

Depth		17"–19 1/2"									
Thickness (Measured in Inches)		2	2	3	3	4	5	6	7	8	
Width		SGL CRD	DBL CRD	SGL CRD	DBL CRD	SGL CRD	DBL CRD	SGL CRD	DBL CRD	SGL CRD	DBL CRD
26	to 28	\$94.05	\$106.12	\$98.20	\$111.70	\$115.84	\$119.99	\$124.13	\$150.40	\$155.26	
28	to 32	\$97.72	\$110.82	\$102.28	\$116.84	\$121.40	\$125.96	\$130.51	\$158.36	\$163.70	
32	to 36	\$101.42	\$115.55	\$106.39	\$122.02	\$126.99	\$131.96	\$136.93	\$166.36	\$172.19	
36	to 40	\$105.15	\$120.32	\$110.53	\$127.23	\$132.61	\$137.99	\$143.38	\$174.41	\$180.72	
40	to 44	\$108.90	\$125.12	\$114.70	\$132.47	\$138.27	\$144.06	\$149.86	\$182.50	\$189.30	
44	to 48	\$120.47	\$138.91	\$127.11	\$147.24	\$153.89	\$160.53	\$167.17	\$201.84	\$209.55	
48	to 52	\$124.55	\$144.11	\$131.64	\$152.92	\$160.01	\$167.09	\$174.18	\$210.50	\$218.73	
52	to 56	\$128.67	\$149.34	\$136.20	\$158.64	\$166.17	\$173.70	\$181.23	\$219.20	\$227.94	
56	to 60	\$132.82	\$154.62	\$140.80	\$164.39	\$172.37	\$180.34	\$188.32	\$227.95	\$237.21	
60	to 66	\$139.10	\$162.59	\$147.75	\$173.09	\$181.73	\$190.38	\$199.02	\$241.16	\$251.20	
66	to 72	\$154.85	\$181.67	\$164.76	\$193.61	\$203.53	\$213.44	\$223.36	\$268.62	\$280.04	
72	to 78	\$161.71	\$190.35	\$172.34	\$203.07	\$213.70	\$224.33	\$234.96	\$282.80	\$295.04	
78	to 88	\$173.31	\$204.92	\$185.13	\$218.94	\$230.77	\$242.60	\$254.42	\$306.59	\$320.21	
88	to 98	\$196.39	\$233.10	\$210.21	\$249.36	\$263.18	\$277.00	\$290.81	\$330.74	\$345.74	
98	to 108	\$209.27	\$249.17	\$224.37	\$266.83	\$281.93	\$297.03	\$312.13	\$355.27	\$371.66	
108	to 120	\$225.09	\$268.85	\$241.73	\$288.21	\$304.85	\$321.49	\$338.13	\$385.18	\$403.25	

CumuPlush fill pricing applies to Standard Outdoor, Direct Fill and Plush fill styles. For up-to-date pricing, please visit www.DesignerCustomSource.com.

Suggested Retail Labor for

Bench Cushions with CumuPlush Fill

Zippers / Ties / Single Cording / Double Cording

PRICING

Depth		20" - 22 1/2"													
Thickness (Measured in Inches)		2	2	3	3	4	4	5	5	6	6	7	7	8	8
Width		SGL CRD	DBL CRD	SGL CRD	DBL CRD	SGL CRD	DBL CRD	SGL CRD	DBL CRD	SGL CRD	DBL CRD	SGL CRD	DBL CRD	SGL CRD	DBL CRD
26	to 28	\$101.68	\$114.47	\$106.30	\$120.52	\$125.14	\$129.75	\$134.37	\$162.95	\$168.36					
28	to 32	\$105.68	\$119.49	\$110.77	\$126.05	\$131.15	\$136.25	\$141.34	\$171.68	\$177.66					
32	to 36	\$109.70	\$124.56	\$115.28	\$131.62	\$137.20	\$142.77	\$148.35	\$180.46	\$187.00					
36	to 40	\$113.76	\$129.65	\$119.81	\$137.23	\$143.28	\$149.34	\$155.39	\$189.28	\$196.38					
40	to 44	\$117.85	\$134.78	\$124.38	\$142.87	\$149.40	\$155.94	\$162.48	\$198.15	\$205.81					
44	to 48	\$130.38	\$149.59	\$137.88	\$158.79	\$166.29	\$173.79	\$181.29	\$219.24	\$227.96					
48	to 52	\$134.83	\$155.15	\$142.84	\$164.90	\$172.91	\$180.93	\$188.95	\$228.73	\$238.04					
52	to 56	\$139.31	\$160.75	\$147.84	\$171.05	\$179.58	\$188.11	\$196.64	\$238.27	\$248.18					
56	to 60	\$143.83	\$166.39	\$152.88	\$177.24	\$186.29	\$195.33	\$204.38	\$247.86	\$258.36					
60	to 66	\$150.66	\$174.91	\$160.48	\$186.59	\$196.42	\$206.24	\$216.07	\$262.32	\$273.73					
66	to 72	\$167.74	\$195.37	\$179.02	\$208.69	\$219.98	\$231.26	\$242.55	\$292.30	\$305.29					
72	to 78	\$175.20	\$204.65	\$187.31	\$218.86	\$230.98	\$243.09	\$255.21	\$307.83	\$321.78					
78	to 88	\$187.81	\$220.24	\$201.31	\$235.94	\$249.44	\$262.94	\$276.44	\$333.87	\$349.42					
88	to 98	\$212.86	\$250.43	\$228.66	\$268.67	\$284.47	\$300.26	\$316.06	\$360.30	\$377.44					
98	to 108	\$226.86	\$267.62	\$244.13	\$287.46	\$304.74	\$322.01	\$339.29	\$387.13	\$405.88					
108	to 120	\$244.04	\$288.67	\$263.10	\$310.45	\$329.51	\$348.57	\$367.63	\$419.83	\$440.52					

CumuPlush fill pricing applies to Standard Outdoor, Direct Fill and Plush fill styles. For up-to-date pricing, please visit www.DesignerCustomSource.com.

Suggested Retail Labor for

Bench Cushions with CumuPlush Fill

Zippers / Ties / Single Cording / Double Cording

PRICING

Depth		23" - 25 1/2"									
Thickness (Measured in Inches)		2	2	3	3	4	5	6	7	8	
Width		SGL CRD	DBL CRD	SGL CRD	DBL CRD	SGL CRD	DBL CRD	SGL CRD	DBL CRD	SGL CRD	DBL CRD
26	to 28	\$109.32	\$122.82	\$114.40	\$129.34	\$134.43	\$139.52	\$144.60	\$175.50	\$181.46	
28	to 32	\$113.63	\$128.17	\$119.27	\$135.27	\$140.90	\$146.53	\$152.17	\$185.01	\$191.61	
32	to 36	\$117.99	\$133.56	\$124.17	\$141.23	\$147.41	\$153.59	\$159.77	\$194.56	\$201.80	
36	to 40	\$122.37	\$138.98	\$129.10	\$147.23	\$153.96	\$160.68	\$167.41	\$204.16	\$212.04	
40	to 44	\$126.79	\$144.44	\$134.07	\$153.27	\$160.54	\$167.82	\$175.09	\$213.81	\$222.33	
44	to 48	\$140.30	\$160.28	\$148.66	\$170.34	\$178.70	\$187.06	\$195.42	\$236.65	\$246.36	
48	to 52	\$145.10	\$166.20	\$154.05	\$176.87	\$185.82	\$194.77	\$203.72	\$246.96	\$257.35	
52	to 56	\$149.95	\$172.16	\$159.48	\$183.46	\$192.99	\$202.52	\$212.06	\$257.33	\$268.41	
56	to 60	\$154.83	\$178.16	\$164.95	\$190.08	\$200.20	\$210.33	\$220.45	\$267.76	\$279.51	
60	to 66	\$162.21	\$187.24	\$173.21	\$200.09	\$211.10	\$222.10	\$233.11	\$283.49	\$296.27	
66	to 72	\$180.63	\$209.08	\$193.29	\$223.77	\$236.43	\$249.08	\$261.74	\$315.97	\$330.55	
72	to 78	\$188.69	\$218.96	\$202.29	\$234.65	\$248.25	\$261.85	\$275.45	\$332.85	\$348.51	
78	to 88	\$202.31	\$235.55	\$217.48	\$252.93	\$268.10	\$283.28	\$298.45	\$361.15	\$378.62	
88	to 98	\$229.33	\$267.77	\$247.10	\$287.99	\$305.76	\$323.53	\$341.30	\$389.85	\$409.15	
98	to 108	\$244.44	\$286.07	\$263.89	\$308.09	\$327.55	\$347.00	\$366.45	\$418.98	\$440.10	
108	to 120	\$262.99	\$308.48	\$284.47	\$332.68	\$354.16	\$375.64	\$397.12	\$454.48	\$477.80	

CumuPlush fill pricing applies to Standard Outdoor, Direct Fill and Plush fill styles. For up-to-date pricing, please visit www.DesignerCustomSource.com.

Suggested Retail Labor for

Bench Cushions with CumuPlush Fill

Zippers / Ties / Single Cording / Double Cording

PRICING

Depth		26" - 28 1/2"									
Thickness (Measured in Inches)		2	2	3	3	4	5	6	7	8	
Width		SGL CRD	DBL CRD	SGL CRD	DBL CRD	SGL CRD	DBL CRD	SGL CRD	DBL CRD	SGL CRD	DBL CRD
26	to 28	\$116.95	\$121.26	\$122.51	\$128.25	\$133.81	\$139.37	\$144.93	\$176.43	\$182.95	
28	to 32	\$121.59	\$126.93	\$127.76	\$134.57	\$140.74	\$146.91	\$153.08	\$186.71	\$193.95	
32	to 36	\$126.27	\$132.65	\$133.05	\$140.93	\$147.71	\$154.49	\$161.28	\$197.04	\$204.99	
36	to 40	\$130.99	\$138.40	\$138.38	\$147.32	\$154.72	\$162.12	\$169.51	\$207.41	\$216.09	
40	to 44	\$135.74	\$144.19	\$143.75	\$153.76	\$161.77	\$169.78	\$177.79	\$217.84	\$227.23	
44	to 48	\$150.22	\$160.37	\$159.44	\$171.29	\$180.51	\$189.73	\$198.95	\$241.75	\$252.46	
48	to 52	\$155.38	\$166.65	\$165.26	\$178.26	\$188.13	\$198.01	\$207.89	\$252.90	\$264.37	
52	to 56	\$160.59	\$172.97	\$171.12	\$185.27	\$195.81	\$206.34	\$216.88	\$264.10	\$276.34	
56	to 60	\$165.83	\$179.34	\$177.03	\$192.33	\$203.53	\$214.72	\$225.92	\$275.36	\$288.36	
60	to 66	\$173.76	\$188.96	\$185.95	\$203.00	\$215.19	\$227.37	\$239.56	\$292.35	\$306.50	
66	to 72	\$193.52	\$211.51	\$207.55	\$227.57	\$241.60	\$255.63	\$269.66	\$326.67	\$342.82	
72	to 78	\$202.18	\$221.99	\$217.26	\$239.17	\$254.25	\$269.34	\$284.42	\$344.89	\$362.26	
78	to 88	\$216.81	\$239.59	\$233.66	\$258.64	\$275.49	\$292.34	\$309.19	\$375.44	\$394.84	
88	to 98	\$245.80	\$273.15	\$265.55	\$295.34	\$315.09	\$334.84	\$354.59	\$406.42	\$427.86	
98	to 108	\$262.02	\$292.56	\$283.66	\$316.76	\$338.39	\$360.02	\$381.66	\$437.85	\$461.34	
108	to 120	\$281.94	\$316.34	\$305.84	\$342.96	\$366.86	\$390.76	\$414.65	\$476.14	\$502.09	

CumuPlush fill pricing applies to Standard Outdoor, Direct Fill and Plush fill styles. For up-to-date pricing, please visit www.DesignerCustomSource.com.

Suggested Retail Labor for

Bench Cushions with CumuPlush Fill

Zippers / Ties / Single Cording / Double Cording

PRICING

Depth		29"–31 1/2"									
Thickness (Measured in Inches)		2	2	3	3	4	5	6	7	8	
Width		SGL CRD	DBL CRD	SGL CRD	DBL CRD	SGL CRD	DBL CRD	SGL CRD	DBL CRD	SGL CRD	DBL CRD
26	to 28	\$124.58	\$139.52	\$130.61	\$146.98	\$153.01	\$159.04	\$165.07	\$200.60	\$207.67	
28	to 32	\$129.55	\$145.52	\$136.26	\$153.69	\$160.40	\$167.11	\$173.82	\$211.65	\$219.52	
32	to 36	\$134.55	\$151.56	\$141.94	\$160.44	\$167.83	\$175.22	\$182.61	\$222.75	\$231.42	
36	to 40	\$139.60	\$157.64	\$147.67	\$167.24	\$175.30	\$183.37	\$191.44	\$233.91	\$243.37	
40	to 44	\$144.68	\$163.77	\$153.43	\$174.07	\$182.82	\$191.57	\$200.32	\$245.11	\$255.37	
44	to 48	\$160.14	\$181.65	\$170.22	\$193.43	\$203.51	\$213.59	\$223.67	\$271.45	\$283.16	
48	to 52	\$165.66	\$188.29	\$176.47	\$200.83	\$211.64	\$222.45	\$233.26	\$283.43	\$295.98	
52	to 56	\$171.22	\$194.97	\$182.76	\$208.27	\$219.81	\$231.35	\$242.89	\$295.47	\$308.87	
56	to 60	\$176.84	\$201.70	\$189.11	\$215.77	\$228.04	\$240.31	\$252.58	\$307.57	\$321.82	
60	to 66	\$185.32	\$211.88	\$198.68	\$227.10	\$240.46	\$253.83	\$267.20	\$325.82	\$341.34	
66	to 72	\$206.41	\$236.50	\$221.81	\$253.93	\$269.33	\$284.73	\$300.12	\$363.33	\$381.06	
72	to 78	\$215.67	\$247.57	\$232.24	\$266.24	\$282.81	\$299.37	\$315.94	\$382.89	\$401.97	
78	to 88	\$231.31	\$266.19	\$249.83	\$286.91	\$305.43	\$323.96	\$342.48	\$415.70	\$437.03	
88	to 98	\$262.27	\$302.45	\$284.00	\$326.62	\$348.34	\$370.07	\$391.79	\$448.96	\$472.55	
98	to 108	\$279.61	\$322.97	\$303.42	\$349.35	\$373.16	\$396.97	\$420.78	\$482.70	\$508.55	
108	to 120	\$300.89	\$348.11	\$327.21	\$377.15	\$403.47	\$429.79	\$456.11	\$523.78	\$552.35	

CumuPlush fill pricing applies to Standard Outdoor, Direct Fill and Plush fill styles. For up-to-date pricing, please visit www.DesignerCustomSource.com.

Suggested Retail Labor for

Bench Cushions with CumuPlush Fill

Zippers / Ties / Single Cording / Double Cording

PRICING

Depth		32" - 35 1/2"									
Thickness (Measured in Inches)		2	2	3	3	4	5	6	7	8	
Width		SGL CRD	DBL CRD	SGL CRD	DBL CRD	SGL CRD	DBL CRD	SGL CRD	DBL CRD	SGL CRD	DBL CRD
26	to	\$132.21	\$147.87	\$138.71	\$155.80	\$162.31	\$168.81	\$175.31	\$213.15	\$220.77	
28	to	\$137.50	\$154.19	\$144.75	\$162.91	\$170.15	\$177.40	\$184.64	\$224.98	\$233.47	
32	to	\$142.84	\$160.56	\$150.83	\$170.05	\$178.04	\$186.03	\$194.03	\$236.85	\$246.22	
36	to	\$148.21	\$166.97	\$156.95	\$177.24	\$185.98	\$194.72	\$203.46	\$248.78	\$259.03	
40	to	\$153.63	\$173.43	\$163.11	\$184.47	\$193.96	\$203.44	\$212.93	\$260.77	\$271.89	
44	to	\$170.06	\$192.34	\$181.00	\$204.97	\$215.91	\$226.85	\$237.79	\$288.85	\$301.56	
48	to	\$175.94	\$199.33	\$187.68	\$212.80	\$224.54	\$236.28	\$248.03	\$301.66	\$315.30	
52	to	\$181.86	\$206.38	\$194.41	\$220.68	\$233.22	\$245.77	\$258.31	\$314.54	\$329.10	
56	to	\$187.84	\$213.47	\$201.18	\$228.61	\$241.96	\$255.30	\$268.65	\$327.47	\$342.97	
60	to	\$196.87	\$224.20	\$211.42	\$240.60	\$255.15	\$269.69	\$284.24	\$346.98	\$363.87	
66	to	\$219.30	\$250.21	\$236.07	\$269.01	\$285.78	\$302.55	\$319.32	\$387.01	\$406.32	
72	to	\$229.16	\$261.88	\$247.21	\$282.03	\$300.08	\$318.14	\$336.19	\$407.92	\$428.71	
78	to	\$245.81	\$281.51	\$266.00	\$303.90	\$324.10	\$344.30	\$364.50	\$442.98	\$466.24	
88	to	\$278.75	\$319.78	\$302.45	\$345.93	\$369.63	\$393.34	\$417.04	\$478.52	\$504.25	
98	to	\$297.19	\$341.42	\$323.18	\$369.98	\$395.97	\$421.96	\$447.94	\$514.55	\$542.77	
108	to	\$319.84	\$367.93	\$348.57	\$399.39	\$428.13	\$456.86	\$485.60	\$558.43	\$589.63	

CumuPlush fill pricing applies to Standard Outdoor, Direct Fill and Plush fill styles. For up-to-date pricing, please visit www.DesignerCustomSource.com.

Suggested Retail Labor for

Bench Cushions with CumuPlush Fill

Zippers / Ties / Single Cording / Double Cording

PRICING

Depth		36"–39 1/2"									
Thickness (Measured in Inches)		2	2	3	3	4	5	6	7	8	
Width		SGL CRD	DBL CRD	SGL CRD	DBL CRD	SGL CRD	DBL CRD	SGL CRD	DBL CRD	SGL CRD	DBL CRD
26	to 28	\$142.39	\$158.98	\$149.52	\$167.55	\$174.68	\$181.80	\$188.93	\$229.87	\$238.22	
28	to 32	\$148.12	\$165.74	\$156.08	\$175.17	\$183.13	\$191.10	\$199.06	\$242.72	\$252.05	
32	to 36	\$153.89	\$172.55	\$162.69	\$182.84	\$191.64	\$200.44	\$209.23	\$255.62	\$265.94	
36	to 40	\$159.70	\$179.40	\$169.33	\$190.55	\$200.19	\$209.82	\$219.46	\$268.59	\$279.89	
40	to 44	\$165.56	\$186.29	\$176.03	\$198.32	\$208.79	\$219.26	\$229.73	\$281.61	\$293.89	
44	to 48	\$183.28	\$206.56	\$195.37	\$220.35	\$232.43	\$244.52	\$256.61	\$312.03	\$326.07	
48	to 52	\$189.64	\$214.04	\$202.63	\$228.75	\$241.73	\$254.71	\$267.70	\$325.95	\$341.03	
52	to 56	\$196.05	\$221.56	\$209.93	\$237.21	\$251.09	\$264.96	\$278.84	\$339.94	\$356.05	
56	to 60	\$202.52	\$229.15	\$217.29	\$245.72	\$260.50	\$275.27	\$290.05	\$353.99	\$371.15	
60	to 66	\$212.28	\$240.61	\$228.40	\$258.58	\$274.70	\$290.82	\$306.95	\$375.18	\$393.90	
66	to 72	\$236.50	\$268.46	\$255.09	\$289.09	\$307.69	\$326.29	\$344.88	\$418.55	\$439.97	
72	to 78	\$247.15	\$280.94	\$267.19	\$303.06	\$323.10	\$343.13	\$363.16	\$441.26	\$464.32	
78	to 88	\$265.14	\$301.91	\$287.58	\$326.53	\$348.97	\$371.40	\$393.83	\$479.33	\$505.15	
88	to 98	\$300.71	\$342.88	\$327.05	\$371.66	\$398.00	\$424.34	\$450.68	\$517.90	\$546.50	
98	to 108	\$320.64	\$366.00	\$349.54	\$397.46	\$426.36	\$455.25	\$484.14	\$557.01	\$588.37	
108	to 120	\$345.11	\$394.32	\$377.07	\$429.01	\$460.98	\$492.94	\$524.90	\$604.60	\$639.30	

CumuPlush fill pricing applies to Standard Outdoor, Direct Fill and Plush fill styles. For up-to-date pricing, please visit www.DesignerCustomSource.com.

Suggested Retail Labor for

Bench Cushions with CumuPlush Fill

Zippers / Ties / Single Cording / Double Cording

PRICING

Depth		40"–43 1/2"									
Thickness (Measured in Inches)		2	2	3	3	4	5	6	7	8	
Width		SGL CRD	DBL CRD	SGL CRD	DBL CRD	SGL CRD	DBL CRD	SGL CRD	DBL CRD	SGL CRD	DBL CRD
26	to 28	\$152.57	\$170.10	\$160.33	\$179.29	\$187.05	\$194.80	\$202.56	\$246.58	\$255.67	
28	to 32	\$158.73	\$177.29	\$167.41	\$187.43	\$196.11	\$204.80	\$213.48	\$260.46	\$270.63	
32	to 36	\$164.94	\$184.53	\$174.54	\$195.63	\$205.23	\$214.84	\$224.44	\$274.40	\$285.66	
36	to 40	\$171.19	\$191.82	\$181.72	\$203.87	\$214.40	\$224.93	\$235.46	\$288.40	\$300.74	
40	to 44	\$177.49	\$199.16	\$188.94	\$212.17	\$223.62	\$235.07	\$246.53	\$302.46	\$315.89	
44	to 48	\$196.51	\$220.79	\$209.75	\$235.72	\$248.95	\$262.19	\$275.42	\$335.21	\$350.58	
48	to 52	\$203.35	\$228.74	\$217.58	\$244.70	\$258.92	\$273.15	\$287.37	\$350.24	\$366.76	
52	to 56	\$210.24	\$236.75	\$225.46	\$253.73	\$268.95	\$284.16	\$299.38	\$365.33	\$383.00	
56	to 60	\$217.19	\$244.82	\$233.40	\$262.83	\$279.03	\$295.24	\$311.45	\$380.50	\$399.32	
60	to 66	\$227.69	\$257.01	\$245.38	\$276.56	\$294.26	\$311.96	\$329.65	\$403.37	\$423.92	
66	to 72	\$253.69	\$286.72	\$274.12	\$309.18	\$329.60	\$350.02	\$370.45	\$450.10	\$473.62	
72	to 78	\$265.15	\$299.99	\$287.16	\$324.10	\$346.11	\$368.12	\$390.13	\$474.59	\$499.94	
78	to 88	\$284.48	\$322.31	\$309.15	\$349.17	\$373.83	\$398.49	\$423.16	\$515.67	\$544.07	
88	to 98	\$322.68	\$365.97	\$351.65	\$397.39	\$426.37	\$455.34	\$484.31	\$557.28	\$588.74	
98	to 108	\$344.10	\$390.58	\$375.89	\$424.95	\$456.74	\$488.54	\$520.33	\$599.46	\$633.98	
108	to 120	\$370.38	\$420.72	\$405.57	\$458.63	\$493.82	\$529.01	\$564.20	\$650.77	\$688.98	

CumuPlush fill pricing applies to Standard Outdoor, Direct Fill and Plush fill styles. For up-to-date pricing, please visit www.DesignerCustomSource.com.

Suggested Retail Labor for

Bench Cushions with CumuPlush Fill

Zippers / Ties / Single Cording / Double Cording

PRICING

Depth		44"–47 1/2"													
Thickness (Measured in Inches)		2	2	3	3	4	4	5	5	6	6	7	7	8	8
Width		SGL CRD	DBL CRD	SGL CRD	DBL CRD	SGL CRD	DBL CRD	SGL CRD	DBL CRD	SGL CRD	DBL CRD	SGL CRD	DBL CRD	SGL CRD	DBL CRD
26	to 28	\$162.76	\$181.21	\$171.14	\$191.03	\$199.42	\$207.80	\$216.19	\$263.29	\$273.12					
28	to 32	\$169.35	\$188.84	\$178.74	\$199.70	\$209.10	\$218.49	\$227.89	\$278.20	\$289.22					
32	to 36	\$175.99	\$196.51	\$186.40	\$208.42	\$218.83	\$229.24	\$239.65	\$293.17	\$305.38					
36	to 40	\$182.68	\$204.24	\$194.10	\$217.19	\$228.61	\$240.04	\$251.46	\$308.21	\$321.60					
40	to 44	\$189.42	\$212.02	\$201.86	\$226.01	\$238.45	\$250.89	\$263.33	\$323.31	\$337.89					
44	to 48	\$209.74	\$235.02	\$224.12	\$251.09	\$265.47	\$279.85	\$294.23	\$358.39	\$375.09					
48	to 52	\$217.06	\$243.45	\$232.52	\$260.64	\$276.11	\$291.58	\$307.04	\$374.53	\$392.49					
52	to 56	\$224.43	\$251.94	\$240.99	\$270.26	\$286.81	\$303.36	\$319.91	\$390.73	\$409.96					
56	to 60	\$231.87	\$260.49	\$249.51	\$279.93	\$297.57	\$315.21	\$332.85	\$407.02	\$427.50					
60	to 66	\$243.10	\$273.42	\$262.37	\$294.55	\$313.82	\$333.09	\$352.36	\$431.57	\$453.95					
66	to 72	\$270.88	\$304.98	\$293.14	\$329.26	\$351.51	\$373.76	\$396.02	\$481.64	\$507.27					
72	to 78	\$283.14	\$319.05	\$307.13	\$345.13	\$369.12	\$393.12	\$417.11	\$507.93	\$535.56					
78	to 88	\$303.82	\$342.71	\$330.72	\$371.80	\$398.70	\$425.59	\$452.49	\$552.02	\$582.99					
88	to 98	\$344.65	\$389.06	\$376.26	\$423.12	\$454.73	\$486.34	\$517.95	\$630.98	\$679.58					
98	to 108	\$367.55	\$415.16	\$402.25	\$452.43	\$487.13	\$521.83	\$556.53	\$641.91	\$679.58					
108	to 120	\$395.65	\$447.12	\$434.06	\$488.26	\$526.67	\$565.09	\$603.51	\$696.94	\$738.65					

CumuPlush fill pricing applies to Standard Outdoor, Direct Fill and Plush fill styles. For up-to-date pricing, please visit www.DesignerCustomSource.com.

Suggested Retail Labor for

Bench Cushions with CumuPlush Fill

Zippers / Ties / Single Cording / Double Cording

PRICING

Depth		48"–59 1/2"													
Thickness (Measured in Inches)		2	2	3	3	4	4	5	5	6	6	7	7	8	8
Width		SGL CRD	DBL CRD	SGL CRD	DBL CRD	SGL CRD	DBL CRD	SGL CRD	DBL CRD	SGL CRD	DBL CRD	SGL CRD	DBL CRD	SGL CRD	DBL CRD
26	to 28	\$172.94	\$192.33	\$181.95	\$202.77	\$211.79	\$220.80	\$229.81	\$238.82	\$247.83	\$256.84	\$265.85	\$274.86	\$283.87	\$292.88
28	to 32	\$179.96	\$200.38	\$190.07	\$211.96	\$222.08	\$232.19	\$242.31	\$252.42	\$262.53	\$272.64	\$282.75	\$292.86	\$302.97	\$313.08
32	to 36	\$187.04	\$208.50	\$198.25	\$221.21	\$232.42	\$243.64	\$254.86	\$266.07	\$277.28	\$288.50	\$299.71	\$310.92	\$322.13	\$333.34
36	to 40	\$194.17	\$216.66	\$206.48	\$230.51	\$242.82	\$255.14	\$267.46	\$279.77	\$292.08	\$304.40	\$316.71	\$329.02	\$341.33	\$353.64
40	to 44	\$201.35	\$224.88	\$214.77	\$239.86	\$253.28	\$266.70	\$280.13	\$293.54	\$306.96	\$320.37	\$333.78	\$347.19	\$360.60	\$374.01
44	to 48	\$222.97	\$249.24	\$238.50	\$266.47	\$281.99	\$297.52	\$313.05	\$328.57	\$344.10	\$359.62	\$375.14	\$390.66	\$406.18	\$421.70
48	to 52	\$230.77	\$258.15	\$247.47	\$276.59	\$293.30	\$310.01	\$326.71	\$343.42	\$360.13	\$376.84	\$393.55	\$410.26	\$426.97	\$443.68
52	to 56	\$238.62	\$267.13	\$256.51	\$286.78	\$304.67	\$322.56	\$340.45	\$358.34	\$376.23	\$394.12	\$412.01	\$429.90	\$447.79	\$465.68
56	to 60	\$246.54	\$276.17	\$265.61	\$297.04	\$316.11	\$335.18	\$354.25	\$373.32	\$392.39	\$411.46	\$430.53	\$449.60	\$468.67	\$487.74
60	to 66	\$258.51	\$289.83	\$279.35	\$312.53	\$333.37	\$354.22	\$375.06	\$395.90	\$416.74	\$437.58	\$458.42	\$479.26	\$500.10	\$520.94
66	to 72	\$288.08	\$323.23	\$312.16	\$349.34	\$373.42	\$397.50	\$421.58	\$445.66	\$469.74	\$493.82	\$517.90	\$541.98	\$566.06	\$590.14
72	to 78	\$301.13	\$338.10	\$327.10	\$366.17	\$392.14	\$418.11	\$444.08	\$470.05	\$496.02	\$521.99	\$547.96	\$573.93	\$599.90	\$625.87
78	to 88	\$323.16	\$363.11	\$352.29	\$394.44	\$423.56	\$452.69	\$481.82	\$510.94	\$540.06	\$569.18	\$598.30	\$627.42	\$656.54	\$685.66
88	to 98	\$366.61	\$412.16	\$400.86	\$448.85	\$483.10	\$517.34	\$551.59	\$585.83	\$620.07	\$654.31	\$688.55	\$722.79	\$757.03	\$791.27
98	to 108	\$391.00	\$439.74	\$428.60	\$479.91	\$517.52	\$555.12	\$592.73	\$630.34	\$667.95	\$705.56	\$743.17	\$780.78	\$818.39	\$856.00
108	to 120	\$420.92	\$473.51	\$462.56	\$517.88	\$559.52	\$601.17	\$642.81	\$684.45	\$726.09	\$767.73	\$809.37	\$851.01	\$892.65	\$934.29

CumuPlush fill pricing applies to Standard Outdoor, Direct Fill and Plush fill styles. For up-to-date pricing, please visit www.DesignerCustomSource.com.

Suggested Retail Labor for

Bench Cushions with CumuPlush Fill

Zippers / Ties / Single Cording / Double Cording

PRICING

Depth		60"-79 1/2"													
Thickness (Measured in Inches)		2	2	3	3	4	4	5	5	6	6	7	7	8	
Width		SGL CRD	DBL CRD	SGL CRD	DBL CRD	SGL CRD	DBL CRD	SGL CRD	DBL CRD	SGL CRD	DBL CRD	SGL CRD	DBL CRD	SGL CRD	DBL CRD
26	to 28	\$203.52	\$225.67	\$214.42	\$238.00	\$248.90	\$259.80	\$270.69	\$330.14	\$270.69	\$330.14	\$342.92	\$330.14	\$342.92	
28	to 32	\$211.85	\$235.03	\$224.11	\$248.76	\$261.02	\$273.29	\$285.55	\$349.17	\$285.55	\$349.17	\$363.55	\$349.17	\$363.55	
32	to 36	\$220.23	\$244.45	\$233.86	\$259.57	\$273.21	\$286.84	\$300.48	\$368.27	\$300.48	\$368.27	\$384.25	\$368.27	\$384.25	
36	to 40	\$228.67	\$253.93	\$243.68	\$270.46	\$285.46	\$300.46	\$315.47	\$387.45	\$315.47	\$387.45	\$405.04	\$387.45	\$405.04	
40	to 44	\$237.18	\$263.48	\$253.56	\$281.40	\$297.78	\$314.15	\$330.52	\$406.71	\$330.52	\$406.71	\$425.90	\$406.71	\$425.90	
44	to 48	\$262.70	\$291.92	\$281.67	\$312.59	\$331.55	\$350.52	\$369.49	\$451.11	\$369.49	\$451.11	\$473.14	\$451.11	\$473.14	
48	to 52	\$271.94	\$302.27	\$292.37	\$324.43	\$344.87	\$365.30	\$385.73	\$471.68	\$385.73	\$471.68	\$495.40	\$471.68	\$495.40	
52	to 56	\$281.24	\$312.69	\$303.14	\$336.36	\$358.25	\$380.15	\$402.05	\$492.33	\$402.05	\$492.33	\$517.76	\$492.33	\$517.76	
56	to 60	\$290.62	\$323.19	\$313.98	\$348.35	\$371.72	\$395.08	\$418.45	\$513.08	\$418.45	\$513.08	\$540.21	\$513.08	\$540.21	
60	to 66	\$304.78	\$339.05	\$330.35	\$366.47	\$392.04	\$417.61	\$443.18	\$544.35	\$443.18	\$544.35	\$574.04	\$544.35	\$574.04	
66	to 72	\$339.71	\$378.00	\$369.27	\$409.59	\$439.16	\$468.72	\$498.28	\$607.82	\$498.28	\$607.82	\$641.86	\$607.82	\$641.86	
72	to 78	\$355.16	\$395.27	\$387.07	\$429.27	\$461.18	\$493.09	\$525.00	\$641.29	\$525.00	\$641.29	\$678.03	\$641.29	\$678.03	
78	to 88	\$381.23	\$424.31	\$417.05	\$462.34	\$498.16	\$533.99	\$569.81	\$697.40	\$569.81	\$697.40	\$738.65	\$697.40	\$738.65	
88	to 98	\$432.56	\$481.44	\$474.72	\$526.04	\$568.19	\$610.35	\$652.50	\$754.19	\$652.50	\$754.19	\$799.96	\$754.19	\$799.96	
98	to 108	\$461.41	\$513.47	\$507.72	\$562.36	\$608.68	\$654.99	\$701.31	\$811.71	\$701.31	\$811.71	\$862.00	\$811.71	\$862.00	
108	to 120	\$496.78	\$552.71	\$548.10	\$606.75	\$658.07	\$709.39	\$760.71	\$881.64	\$760.71	\$881.64	\$937.36	\$881.64	\$937.36	

CumuPlush fill pricing applies to Standard Outdoor, Direct Fill and Plush fill styles. For up-to-date pricing, please visit www.DesignerCustomSource.com.

Suggested Retail Labor for

Bench Cushions with CumuPlush Fill

Zippers / Ties / Single Cording / Double Cording

PRICING

Depth		80"													
Thickness (Measured in Inches)		2	2	3	3	4	4	5	5	6	6	7	7	8	8
Width		SGL CRD	DBL CRD	SGL CRD	DBL CRD	SGL CRD	DBL CRD	SGL CRD	DBL CRD	SGL CRD	DBL CRD	SGL CRD	DBL CRD	SGL CRD	DBL CRD
26	to 28	\$254.50	\$281.24	\$268.54	\$296.71	\$310.75	\$324.79	\$338.83	\$413.70	\$430.16	\$456.46	\$482.84	\$509.33	\$535.91	\$595.69
28	to 32	\$264.99	\$292.76	\$280.84	\$310.08	\$325.93	\$341.78	\$357.63	\$437.87	\$456.46	\$482.84	\$509.33	\$535.91	\$595.69	\$624.05
32	to 36	\$275.55	\$304.36	\$293.21	\$323.52	\$341.18	\$358.85	\$376.51	\$462.14	\$482.84	\$509.33	\$535.91	\$595.69	\$624.05	\$652.52
36	to 40	\$286.19	\$316.04	\$305.67	\$337.04	\$356.52	\$376.00	\$395.47	\$486.49	\$509.33	\$535.91	\$595.69	\$624.05	\$652.52	\$681.10
40	to 44	\$296.91	\$327.80	\$318.20	\$350.64	\$371.94	\$393.23	\$414.52	\$510.95	\$535.91	\$595.69	\$624.05	\$652.52	\$681.10	\$724.16
44	to 48	\$328.92	\$363.06	\$353.62	\$389.45	\$414.15	\$438.85	\$463.55	\$567.01	\$595.69	\$624.05	\$652.52	\$681.10	\$724.16	\$765.55
48	to 52	\$340.55	\$375.80	\$367.19	\$404.17	\$430.81	\$457.45	\$484.09	\$593.11	\$624.05	\$652.52	\$681.10	\$724.16	\$765.55	\$810.11
52	to 56	\$352.27	\$388.63	\$380.85	\$418.98	\$447.56	\$476.14	\$504.73	\$619.33	\$652.52	\$681.10	\$724.16	\$765.55	\$810.11	\$856.12
56	to 60	\$364.07	\$401.56	\$394.60	\$433.88	\$464.40	\$494.93	\$525.45	\$645.65	\$681.10	\$724.16	\$765.55	\$810.11	\$856.12	\$933.23
60	to 66	\$381.91	\$421.09	\$415.35	\$456.38	\$489.82	\$523.26	\$556.70	\$685.32	\$724.16	\$765.55	\$810.11	\$856.12	\$933.23	\$993.32
66	to 72	\$425.76	\$469.28	\$464.46	\$510.01	\$548.71	\$587.41	\$626.12	\$765.55	\$810.11	\$856.12	\$933.23	\$993.32	\$1,011.18	\$1,185.74
72	to 78	\$445.20	\$490.54	\$487.01	\$534.44	\$576.25	\$618.05	\$659.86	\$807.98	\$856.12	\$933.23	\$993.32	\$1,011.18	\$1,090.02	\$1,185.74
78	to 88	\$478.00	\$526.32	\$524.99	\$575.50	\$622.49	\$669.48	\$716.46	\$879.13	\$933.23	\$993.32	\$1,011.18	\$1,090.02	\$1,185.74	\$1,271.66
88	to 98	\$542.48	\$596.90	\$597.82	\$654.68	\$710.02	\$765.35	\$820.69	\$951.11	\$1,011.18	\$1,090.02	\$1,185.74	\$1,271.66	\$1,367.54	\$1,463.42
98	to 108	\$578.75	\$636.36	\$639.59	\$699.77	\$760.61	\$821.45	\$882.29	\$1,023.97	\$1,090.02	\$1,185.74	\$1,271.66	\$1,367.54	\$1,463.42	\$1,559.30
108	to 120	\$623.22	\$684.69	\$690.67	\$754.87	\$822.32	\$889.77	\$957.22	\$1,112.50	\$1,185.74	\$1,271.66	\$1,367.54	\$1,463.42	\$1,559.30	\$1,655.18

CumuPlush fill pricing applies to Standard Outdoor, Direct Fill and Plush fill styles. For up-to-date pricing, please visit www.DesignerCustomSource.com.

Chaise, Double Chaise and Steamer

PRICING

Use the cushion pricing charts, and add the following upcharges below for Chaise, Double Chaise and Steamer cushions. Please note the size ranges.

For pricing purposes, use the “total width” and then add an amount to account for the time and labor for the individual cuts.

CUSHION SET-UP CHARGE

- For a pinched method, add \$8.00 per pinch. For a single break chaise, add \$8.00 to the cost, a double break \$16.00, and a triple break \$24.00.
- For an unjoined seat and back cushion, add \$12.00 per break.
- For a joining piece to connect the seat and back section, add \$16.00 per break.

Example 1 – Chaise Cushion

Using the pricing grid below, overall width will be used.

For example, if a customer wants a chaise cushion that is 45” seat and 30” back, the total width is 75” and is priced in the 72”-78” wide cushion range. Next add the following:

- For a pinched method, add \$8.00 per pinch. For a single break chaise add \$8.00 to the cost, a double break \$16.00, and a triple break \$24.00.
- For an unjoined seat and back chaise cushion, add \$12.00 per break.
- For a joining piece to connect the seat and back section of the chaise, add \$16.00 per break. For a single break chaise, add \$16.00 to the cost, a double break \$32.00, and a triple break \$48.00.

For example, a 25” depth x 75” length x 3” boxed chaise cost is \$200.69. With one break, add \$8.00 for a total retail labor cost of \$208.69. With the designer discount, cost is \$104.35. If you priced these as single cushions, the designer’s cost would be \$123.00.

Depth			26”-28 ½”				
Thickness (Measured in Inches)			2	2	3	3	4
Width			KNIFE	BOXED	KNIFE	BOXED	BOXED
26	to	28	\$107.04	\$111.35	\$112.60	\$118.34	\$123.90
28	to	32	\$110.72	\$115.11	\$116.89	\$122.75	\$128.92
32	to	36	\$114.44	\$118.92	\$121.22	\$127.20	\$133.98
36	to	40	\$118.19	\$122.76	\$125.59	\$131.68	\$139.08
40	to	44	\$121.98	\$126.64	\$129.99	\$136.21	\$144.22
44	to	48	\$134.48	\$139.57	\$143.70	\$150.48	\$159.70
48	to	52	\$138.62	\$143.80	\$148.49	\$155.41	\$165.29
52	to	56	\$142.79	\$148.08	\$153.33	\$160.38	\$170.92
56	to	60	\$147.01	\$152.41	\$158.21	\$165.40	\$176.60
60	to	66	\$153.40	\$158.96	\$165.59	\$173.00	\$185.19
66	to	72	\$170.22	\$176.31	\$184.24	\$192.37	\$206.40
72	to	78	\$177.24	\$183.52	\$192.32	\$200.69	\$215.78
78	to	88	\$189.14	\$195.73	\$205.99	\$214.77	\$231.62
88	to	98	\$213.56	\$220.90	\$233.31	\$243.10	\$262.85
98	to	108	\$226.89	\$234.60	\$248.52	\$258.80	\$280.43
108	to	120	\$243.34	\$251.51	\$267.23	\$278.13	\$302.03

Example 2 – Seat and Back (As a Set) Combinations

Using the pricing grid below, overall width will be used.

For example, if a customer wants a seat and back cushion that is 20” seat depth and 20” back height, the total width is 40” and would be priced like a 40” wide cushion. Then add:

- For a pinched method, add \$8.00 per pinch.
- For an unjoined seat and back cushion, add \$12.00.
- For a joining piece to connect the seat and back, add \$16.00.

Apply this Set Method to the Following Styles:

- Chaise
- Seat & Back Sets

The Three Methods Used to Assemble Loveseat and Sofa Sets:

- Pinched Method (Primarily used for chaise, steamer and seat and back connected cushion.)
- Unjoined (Primarily used for loveseat and sofa sets.)
- Joining Piece (Primarily used for thick chaise and thick seat and back cushion sets.)

Depth			26 – 28 ½				
Thickness (Measured in Inches)			2	2	3	3	4
Width			KNIFE	BOXED	KNIFE	BOXED	BOXED
26	to	28	\$107.04	\$111.35	\$112.60	\$118.34	\$123.90
28	to	32	\$110.72	\$115.11	\$116.89	\$122.75	\$128.92
32	to	36	\$114.44	\$118.92	\$121.22	\$127.20	\$133.98
36	to	40	\$118.19	\$122.76	\$125.59	\$131.68	\$139.08
40	to	44	\$121.98	\$126.64	\$129.99	\$136.21	\$144.22
44	to	48	\$134.48	\$139.57	\$143.70	\$150.48	\$159.70
48	to	52	\$138.62	\$143.80	\$148.49	\$155.41	\$165.29
52	to	56	\$142.79	\$148.08	\$153.33	\$160.38	\$170.92
56	to	60	\$147.01	\$152.41	\$158.21	\$165.40	\$176.60
60	to	66	\$153.40	\$158.96	\$165.59	\$173.00	\$185.19
66	to	72	\$170.22	\$176.31	\$184.24	\$192.37	\$206.40
72	to	78	\$177.24	\$183.52	\$192.32	\$200.69	\$215.78
78	to	88	\$189.14	\$195.73	\$205.99	\$214.77	\$231.62
88	to	98	\$213.56	\$220.90	\$233.31	\$243.10	\$262.85
98	to	108	\$226.89	\$234.60	\$248.52	\$258.80	\$280.43
108	to	120	\$243.34	\$251.51	\$267.23	\$278.13	\$302.03



DRAPES

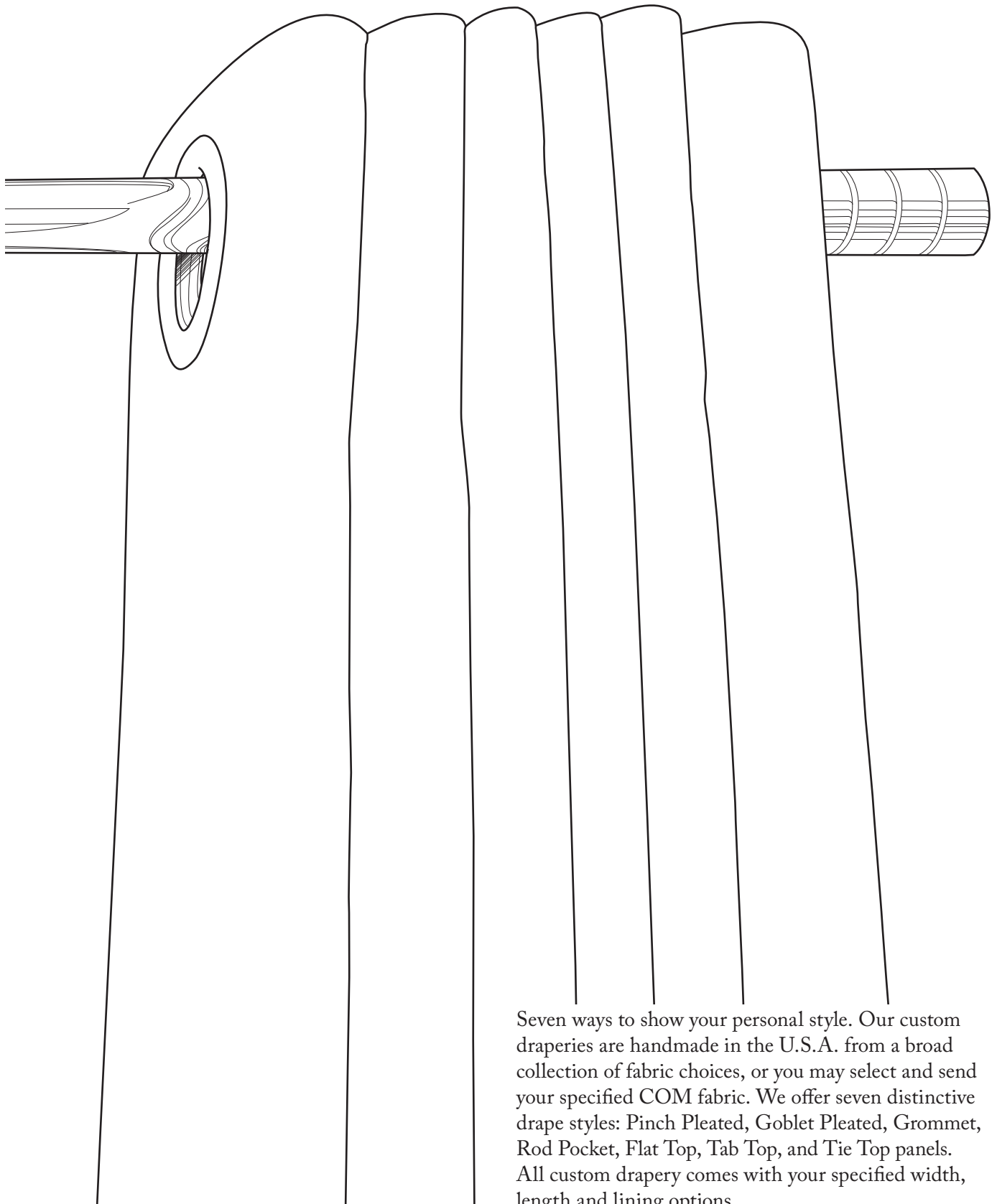

Seven ways to show your personal style. Our custom draperies are handmade in the U.S.A. from a broad collection of fabric choices, or you may select and send your specified COM fabric. We offer seven distinctive drape styles: Pinch Pleated, Goblet Pleated, Grommet, Rod Pocket, Flat Top, Tab Top, and Tie Top panels. All custom drapery comes with your specified width, length and lining options.



PINCH PLEAT DRAPES

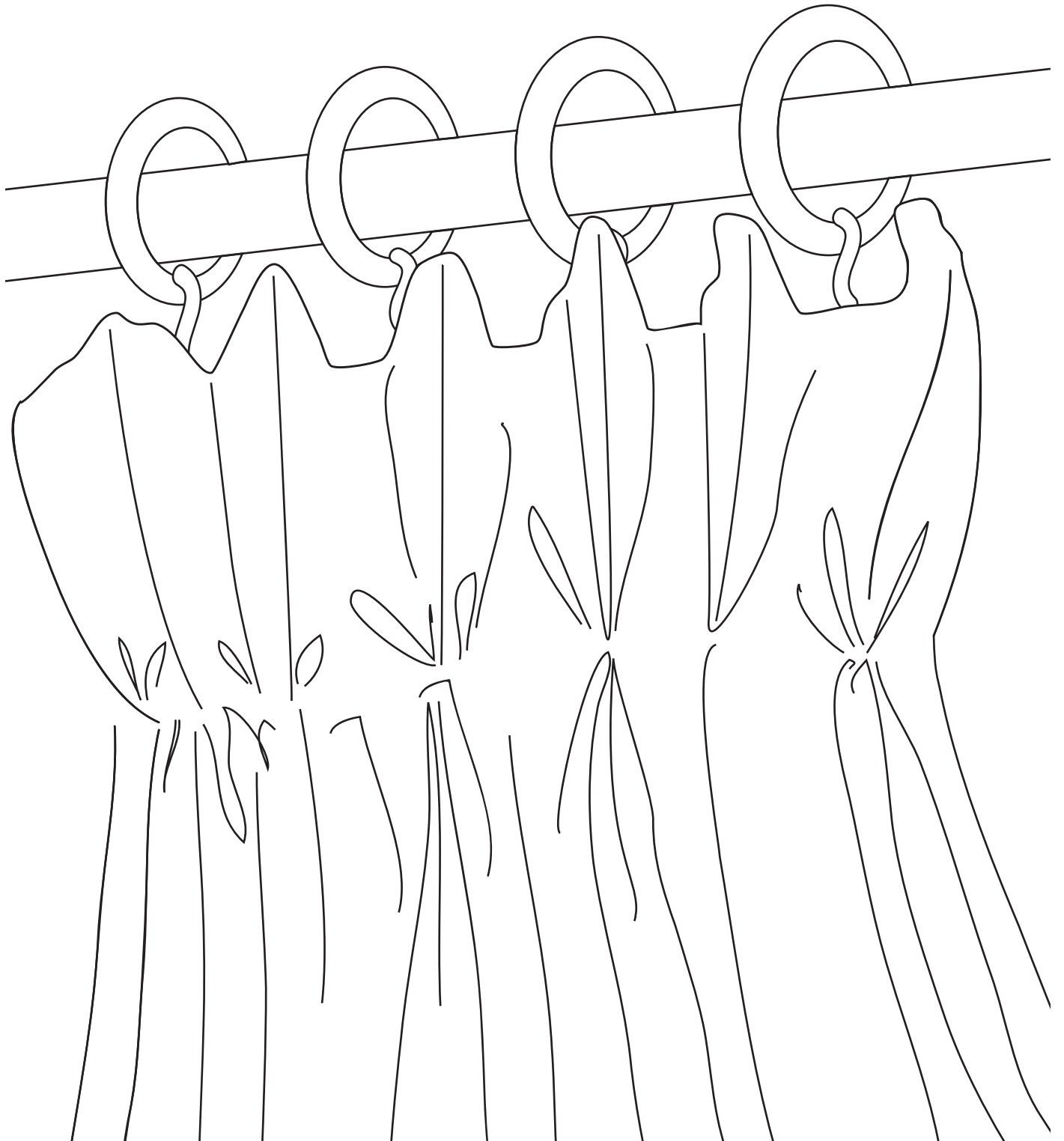

PINCH PLEAT DRAPES



PINCH PLEAT DRAPES, both Euro and French, provide custom elegance and sophistication. Pinch pleat drapes are hand-pleated, pre-pinned and ready for installation.

- 4" double top with crinoline
- 3-finger French pleat, tacked at the bottom of the pleat
- 4" double bottom hem
- 2 ½" x fullness standard

Suggested Allowances for COM Fabric

LENGTH

Finished length + 8" (4" double bottom hem) + 8" (4" double top) + 2" (work) = cut length

WIDTH

Rod face x 2 ½ (fullness) + returns + 5" (side hems) ÷ width of fabric = # of cuts needed

ALLOWANCE FOR REPEAT

Option 1

- Panel cut length ÷ fabric repeat (in inches) = N (round to the nearest inch)
- N x fabric repeat = new panel cut length
- For example:
 - 108" (cut length) ÷ 26" (repeat) = 4.15" (round up to nearest inch)
 - 5" x 26" = 130" (new cut length) ÷ 36" = 3.6 yards (round up to the nearest half yard)

Option 2

- The first cut is at the cut length, and the other cuts are at the adjusted cut length to allow for the repeat. Just add one less repeat than the width of fabric.
- For example:
 - 3 widths of fabric, add 2 repeats
 - 4 widths of fabric, add 3 repeats
- For example:
 - 4 x 108" (cut length) = 432"
 - 432" + 78" (26" repeat x 3) = 510" ÷ 36" = 14.17 yards (round up to the nearest half yard)

Standard 3 ½" returns and side hems are inclusive in the rod face measurement. Use the rod face (bracket to bracket) measurement to determine the number of widths needed. Always round up to nearest whole width.

Below is a quick reference to drapery widths required for application. Allowances provide proper fullness based on a 54" width fabric.

Widths	1	1.5	2	2.5	3	3.5	4	4.5	5	5.5	6
Rod Face	29"	41"	53"	65"	77"	89"	101"	113"	125"	137"	150"



GOBLET PLEAT DRAPES

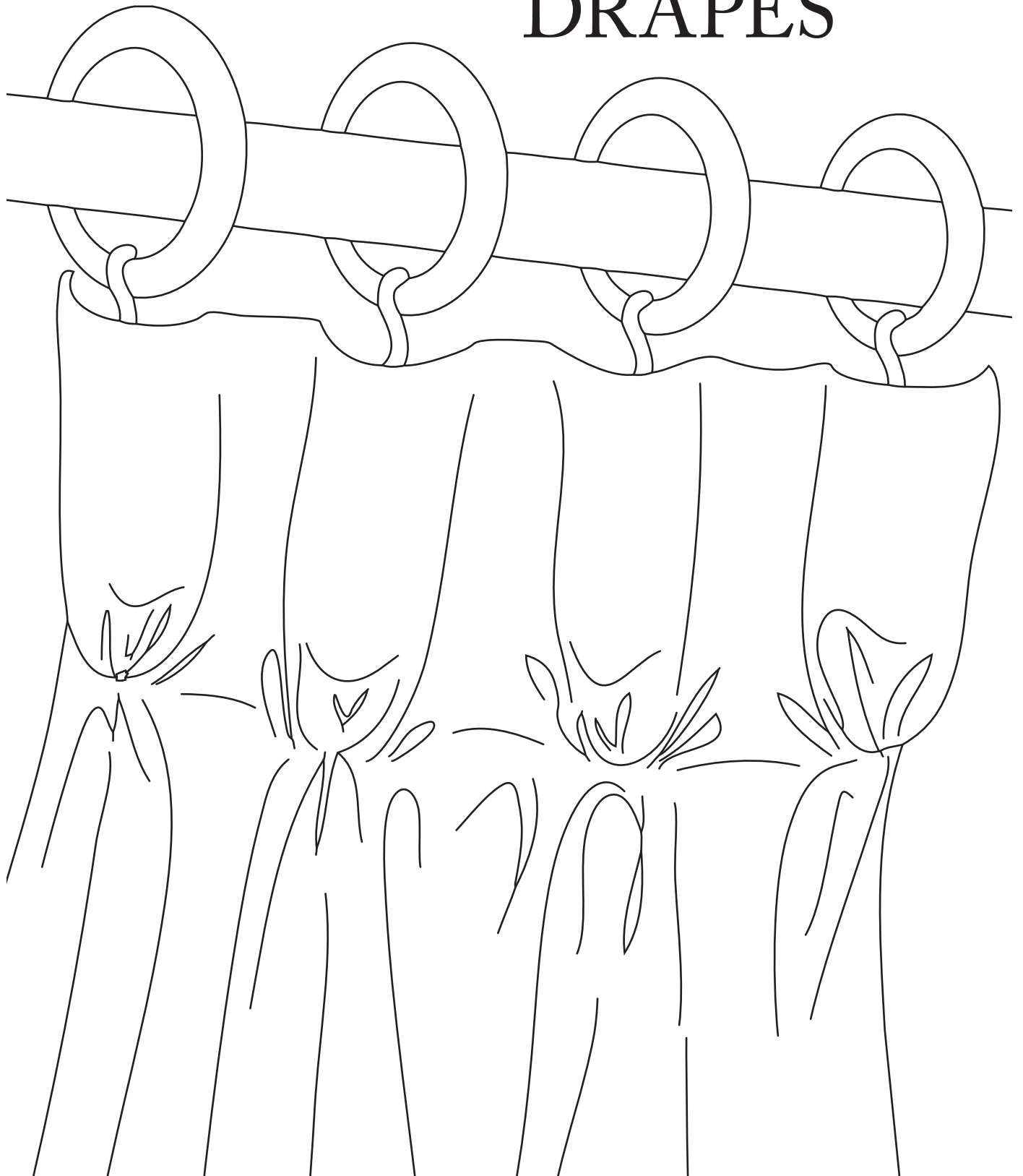

GOBLET PLEAT DRAPES



GOBLET PLEAT DRAPES offer sophistication in any setting of your home. The soft “goblet” formed at the top of the drapery pleats give this drape its descriptive name. Goblet pleat drapes are hand-pleated, pre-pinned and ready for installation.

- 4” double top with crinoline
- Single tops may be used, depending on the thickness of the fabric
- Seams are not pattern matched due to construction but are hidden behind pleats

Suggested Allowances for COM Fabric

LENGTH

Finished length + 8” (4” double bottom hem) + 8” (4” double top) + 2” (work) = cut length

WIDTH

Rod face x 3 (fullness) + returns + ease for fullness + 6” (side hems) ÷ width of fabric = # of cuts needed

ALLOWANCE FOR REPEAT

Option 1

- Panel cut length ÷ fabric repeat (in inches) = N (round to the nearest inch)
- N x fabric repeat = new panel cut length
- For example:
 - 108” (cut length) ÷ 26” (repeat) = 4.15” (round up to nearest inch)
 - 5” x 26” = 130” (new cut length) ÷ 36” = 3.6 yards (round up to the nearest half yard)

Option 2

- The first cut is at the cut length, and the other cuts are at the adjusted cut length to allow for the repeat. Just add one less repeat than the width of fabric.
- For example:
 - 3 widths of fabric, add 2 repeats
 - 4 widths of fabric, add 3 repeats
- For example:
 - 4 x 108” (cut length) = 432”
 - 432” + 78” (26” repeat x 3) = 510” ÷ 36” = 14.17 yards (round to the nearest half yard)

Standard 3 ½” returns and side hems are inclusive in the rod face measurement. Use the rod face (bracket to bracket) measurement to determine the number of widths needed. Always round up to nearest whole width.

Below is a quick reference to drapery widths required for application. Allowances provide proper fullness based on a 54” width fabric.

Widths	1	1.5	2	2.5	3	3.5	4	4.5	5	5.5	6
Rod Face	29”	41”	53”	65”	77”	89”	101”	113”	125”	137”	150”

GROMMET DRAPES

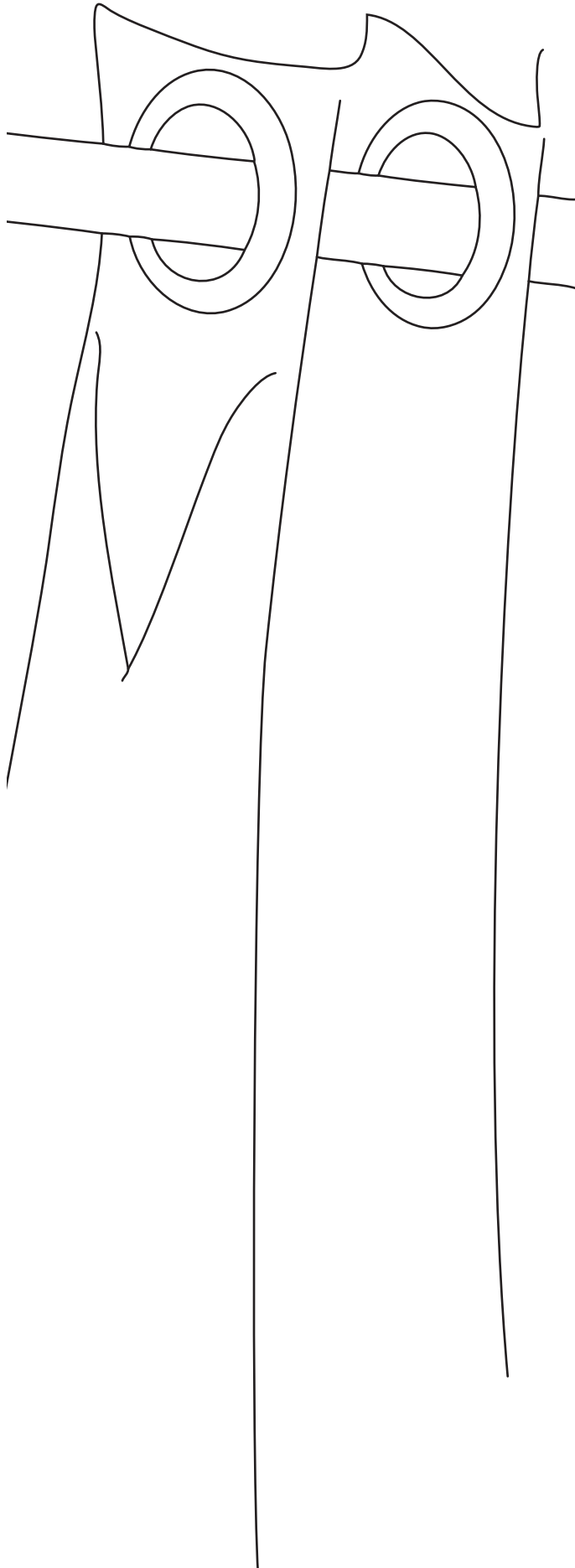

GROMMET DRAPES are a contemporary style that can be used in a formal or casual setting. We recommend this style for both indoor and outdoor applications.

Once a single width panel is installed on a rod, it can be adjusted between 24 inches and 33 inches. “Drapery Width” is the total area in width that you want your drape to cover (the width of the opening in which you are covering).

Suggested Allowances for COM Fabric

LENGTH

Finished length + 8” (4” double top) + 8” (4” double bottom hem) + 2” work = cut length

WIDTH

Rod face x 2 (fullness) + 2 returns + 6” (side hems) ÷ width of fabric = # of cuts needed

ALLOWANCE FOR REPEAT

Option 1

- Panel cut length ÷ fabric repeat (in inches) = N (round to the nearest inch)
- N x fabric repeat = new panel cut length
- For example:
 - 108” (cut length) ÷ 26” (repeat) = 4.15” (round up to nearest inch)
 - 5” x 26” = 130” (new cut length) ÷ 36” = 3.6 yards (round up to the nearest half yard)

GROMMET DRAPES



Option 2

- The first cut is at the cut length, and the other cuts are at the adjusted cut length to allow for the repeat. Just add one less repeat than the width of fabric.
- For example:
 - 3 widths of fabric, add 2 repeats
 - 4 widths of fabric, add 3 repeats
- For example:
 - $4 \times 108''$ (cut length) = 432''
 - $432'' + 78''$ (26'' repeat \times 3) = 510'' \div 36'' = 14.17 yards (round up to the nearest half yard)

Use the rod face (bracket to bracket) measurement to determine the number of widths needed. Always round up to nearest whole width.

GROMMET FINISHES

- Antique Brass
- Brass
- Antique Copper
- Matte Nickel
- Nickel
- Black

GROMMET SIZES

- 1 $\frac{7}{16}$ ''
- 1 $\frac{9}{16}$ ''
- 2''
- 2 $\frac{1}{2}$ ''
- 3''
- 1 $\frac{9}{16}$ '' Square (Antique Brass, Nickel and Black)

Returns are measured from drapery edge to center of first grommet.

Standard returns will be 3"-4" to center of first grommet. Return measure is relevant to grommet size.

An even number of grommets must be used.

8 grommets per 54" width of fabric is standard.

Spacing is approximately 6"-6 $\frac{1}{2}$ " between grommets, center to center of grommet (based on 8 grommets per width).

It is best if space size and number of grommets used be determined using workroom discretion based on size of drapery.

We cannot "hide" seams on grommet tops. Seams will fall on either side of the grommet.

The workroom will do their best to place the seam where least visible whenever possible.

Specifications

4" double header for smaller grommets, and 6" double header for larger grommets. Unless otherwise specified, top of grommets are set 1" from top of header.

Note: Grommet and rod size selection effect rod face coverage.

Below is a quick reference to drapery widths required for application. Allowances provide proper fullness based on a 54" width fabric.

Widths	1	1.5	2	2.5	3	3.5	4	4.5	5	5.5	6
Rod Face	48"	72"	96"	120"	144"	168"	192"	216"	240"	246"	288"



ROD POCKET DRAPES

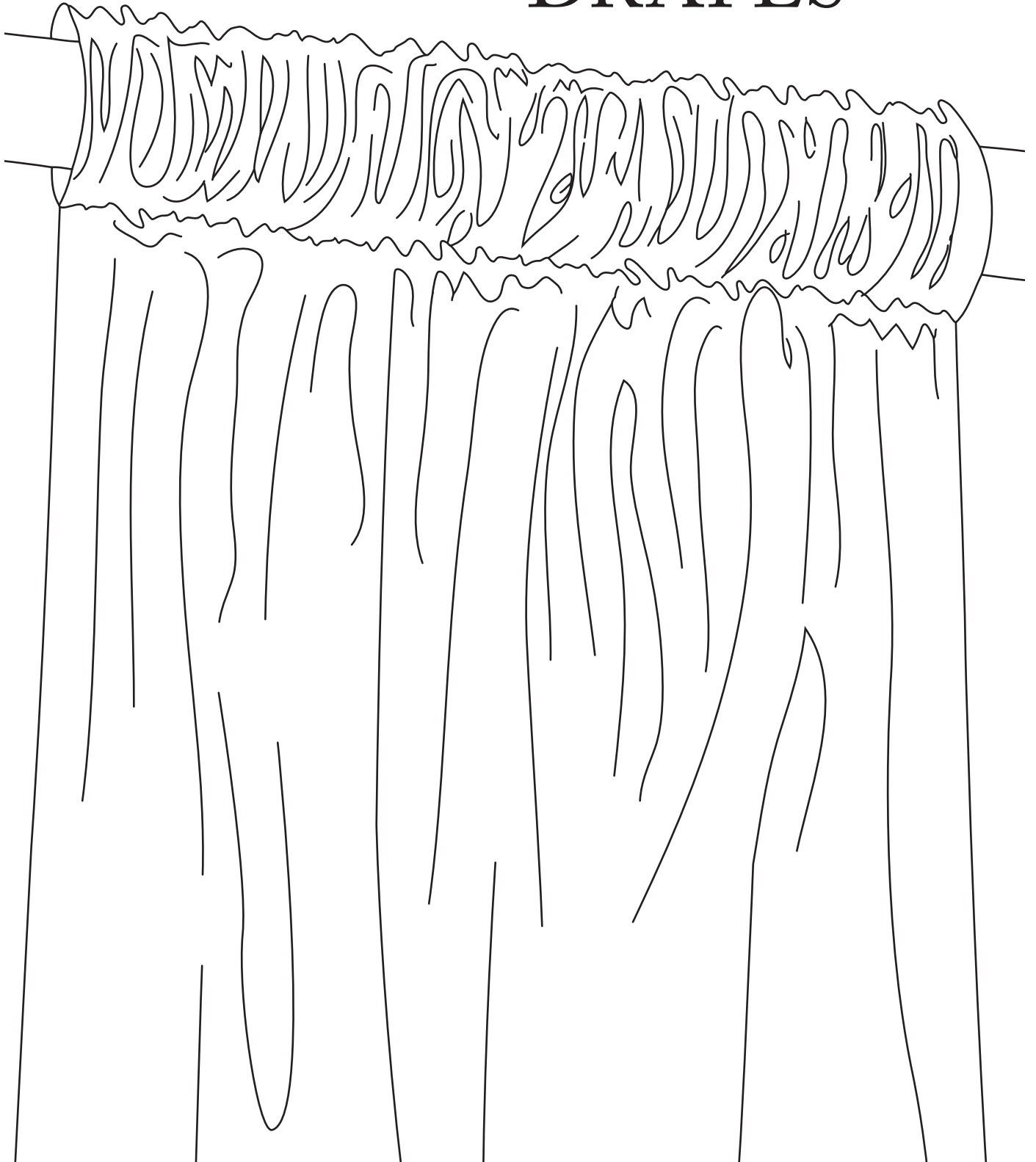

ROD POCKET DRAPES



The simple and sophisticated **ROD POCKET DRAPE** adds beauty and style to any room. Finished with a rod pocket casing to accommodate your decorative rod, the rod pocket drape is timeless in its simplistic design.

- Standard fullness on regular rod pockets is 2 ½.
- Specify rod pocket size

We recommend this style for both indoor and outdoor applications.

Suggested Allowances for COM Fabric

LENGTH

Finished length + 8" (4" double bottom hem) + 8" (4" double top) + 2" (work) = cut length

WIDTH

Rod face x 2 ½ (fullness) + returns (ease for fullness) + 6" (side hems) ÷ width of fabric = # of cuts needed

ALLOWANCE FOR REPEAT

Option 1

- Panel cut length ÷ fabric repeat (in inches) = N (round to the nearest inch)
- N x fabric repeat = new panel cut length
- For example:
 - 108" (cut length) ÷ 26" (repeat) = 4.15" (round up to nearest inch)
 - 5" x 26" = 130" (new cut length) ÷ 36" = 3.6 yards (round up to the nearest half yard)

Option 2

- The first cut is at the cut length, and the other cuts are at the adjusted cut length to allow for the repeat. Just add one less repeat than the width of fabric.
- For example:
 - 3 widths of fabric, add 2 repeats
 - 4 widths of fabric, add 3 repeats
- For example:
 - 4 x 108" (cut length) = 432"
 - 432" + 78" (26" repeat x 3) = 510" ÷ 36" = 14.17 yards (round up to the nearest half yard)

Use the rod face (bracket to bracket) measurement to determine the number of widths needed. Always round up to nearest whole width.

Below is a quick reference to drapery widths required for application. Allowances provide proper fullness based on a 54" width fabric.

Widths Rod Face	1 48"	1.5 72"	2 96"	2.5 120"	3 144"	3.5 168"	4 192"	4.5 216"	5 240"	5.5 246"	6 288"
--------------------	----------	------------	----------	-------------	-----------	-------------	-----------	-------------	-----------	-------------	-----------



FLAT TOP DRAPES

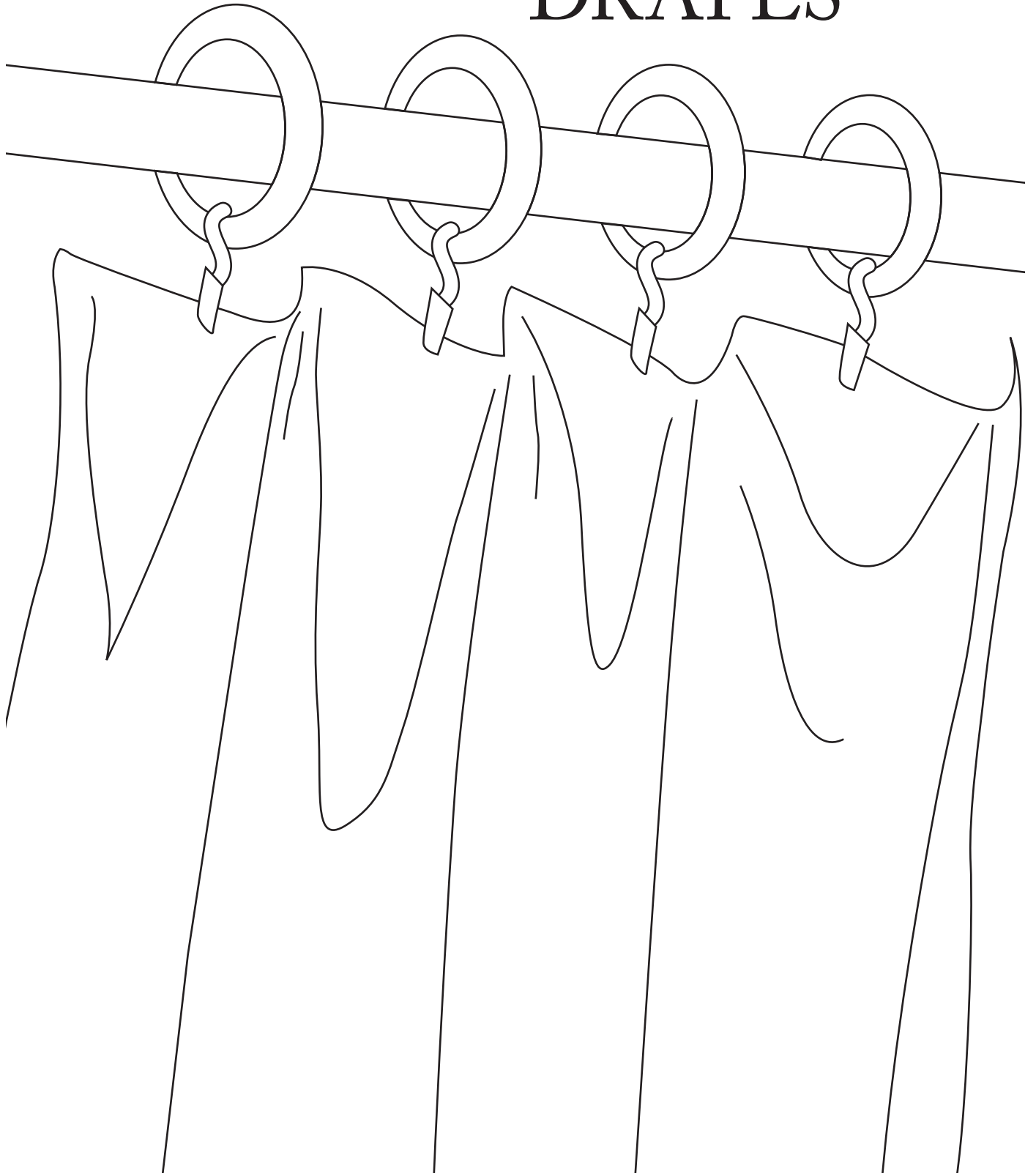

FLAT TOP DRAPES



FLAT TOP DRAPES are hung from rings as decorative or functional panels. These drapes provide a relaxed and casual look and will work on just about any rod or pole. With the flat top style, the top of the drape is hemmed with a light stiffening fabric that gives some body. The drape is attached to the rings of the rod with drapery pin hooks or can be attached to clip rings to allow the drape to softly cup between the rings. This drape comes standard with set drapery pins. Drapery pins are set approximately 12" apart.

Suggested Allowances for COM Fabric

LENGTH

Finished length + 10" (facing) + 1" (seaming) + 8" (4" double bottom hem) + 4" work = cut length

WIDTH

Rod face + 2 (fullness) + returns + 6" (side hems) ÷ width of fabric - # of cuts needed

ALLOWANCE FOR REPEAT

Option 1

- Panel cut length ÷ fabric repeat (in inches) = N (round to the nearest inch)
- N x fabric repeat = new panel cut length
- For example:
 - 108" (cut length) ÷ 26" (repeat) = 4.15" (round up to nearest inch)
 - 5" x 26" = 130" (new cut length) ÷ 36" = 3.6 yards (round up to the nearest half yard)

Option 2

- The first cut is at the cut length, and the other cuts are at the adjusted cut length to allow for the repeat. Just add one less repeat than the width of fabric.
- For example:
 - 3 widths of fabric, add 2 repeats
 - 4 widths of fabric, add 3 repeats
- For example:
 - 4 x 108" (cut length) = 432"
 - 432" + 78" (26" repeat x 3) = 510" ÷ 36" = 14.17 yards (round up to the nearest half yard)

Use the rod face (bracket to bracket) measurement to determine the number of widths needed. Always round up to nearest whole width.

Below is a quick reference to drapery widths required for application. Allowances provide proper fullness based on a 54" width fabric.

Widths	1	1.5	2	2.5	3	3.5	4	4.5	5	5.5	6
Rod Face	48"	72"	96"	120"	144"	168"	192"	216"	240"	246"	288"



TAB TOP DRAPES



TAB TOP DRAPES



TAB TOP DRAPES are easy to install, and add simplicity to your life and your home. These classic drapes are made with no rings or hooks, which creates a free-hanging drape with fabric tabs at the top. We recommend this style for both indoor and outdoor applications.

Tabs are set approximately 12" apart.

Standard tabs are 2" wide x 4" long.

Suggested Allowances for COM Fabric

LENGTH

Finished length – the tab length + 2" work + 1" (seaming) + 8" (4" double bottom hem) = cut length

WIDTH

Rod face x 2 (fullness) + returns + 6" (side hems) ÷ width of fabric = # of cuts needed

ALLOWANCE FOR REPEAT

Option 1

- Panel cut length ÷ fabric repeat (in inches) = N (round to the nearest inch)
- N x fabric repeat = new panel cut length
- For example:
 - 108" (cut length) ÷ 26" (repeat) = 4.15" (round up to nearest inch)
 - 5" x 26" = 130" (new cut length) ÷ 36" = 3.6 yards (round up to the nearest half yard)

Option 2

- The first cut is at the cut length, and the other cuts are at the adjusted cut length to allow for the repeat. Just add one less repeat than the width of fabric.
- For example:
 - 3 widths of fabric, add 2 repeats
 - 4 widths of fabric, add 3 repeats
- For example:
 - 4 x 108" (cut length) = 432"
 - 432" + 78" (26" repeat x 3) = 510" ÷ 36" = 14.17 yards (round up to the nearest half yard)

Use the rod face (bracket to bracket) measurement to determine the number of widths needed. Always round up to nearest whole width.

Below is a quick reference to drapery widths required for application. Allowances provide proper fullness based on a 54" width fabric.

Widths	1	1.5	2	2.5	3	3.5	4	4.5	5	5.5	6
Rod Face	48"	72"	96"	120"	144"	168"	192"	216"	240"	246"	288"



TIE TOP DRAPES



TIE TOP DRAPES



TIE TOP DRAPES are very simple to install, needing little to no instructions at all. Choose your own style by creating bows or knots with your ties. Our tie tab drapes are made of premium quality, durable reinforced professional stitching. Tie tabs are available in ½” or 1” wide (please specify when ordering) by 12” long for rods up to 2”. There are 7 ties on each 48” panel.

We recommend this style for both indoor and outdoor applications.

Suggested Allowances for COM Fabric

LENGTH

Finished length (not including ties) + 10” (facing) + 1” (seaming) + 8” (4” double bottom hem) + 2” work = cut length

WIDTH

Rod face x 2 (fullness) + returns + 6” (side hems) ÷ width of fabric = # of cuts needed

ALLOWANCE FOR REPEAT

Option 1

- Panel cut length ÷ fabric repeat (in inches) = N (round to the nearest inch)
- N x fabric repeat = new panel cut length
- For example:
 - 108” (cut length) ÷ 26” (repeat) = 4.15” (round up to nearest inch)
 - 5” x 26” = 130” (new cut length) ÷ 36” = 3.6 yards (round up to the nearest half yard)

Option 2

- The first cut is at the cut length, and the other cuts are at the adjusted cut length to allow for the repeat. Just add one less repeat than the width of fabric.
- For example:
 - 3 widths of fabric, add 2 repeats
 - 4 widths of fabric, add 3 repeats
- For example:
 - 4 x 108” (cut length) = 432”
 - 432” + 78” (26” repeat x 3) = 510” ÷ 36” = 14.17 yards (round up to the nearest half yard)

Use the rod face (bracket to bracket) measurement to determine the number of widths needed. Always round up to nearest whole width.

Below is a quick reference to drapery widths required for application. Allowances provide proper fullness based on a 54” width fabric.

Widths	1	1.5	2	2.5	3	3.5	4	4.5	5	5.5	6
Rod Face	48”	72”	96”	120”	144”	168”	192”	216”	240”	246”	288”



DRAPERY STANDARDS

Maximum finished dimensions: 150”L x 288”W (standard in all styles.) If your needs exceed these dimensions, please contact us for a quote.

Pinch pleat are made with a three-fold French pleat at top.

Headings are 4” doubled with a non-woven buckram. If fabric is too bulky, a 4” single top will be constructed.

Fabric is surged to the crinoline on single tops.

Rod pockets are made with double heading and pockets unless specified, or if fabric is too bulky, single tops will be constructed.

Standard overlaps and returns on pinched draperies are made at 3 ½”. Please specify if different size return is required. Note adjustments in “Order Notes”.

Comparable fullness will be used for spacing between pleats on all pleated draperies that will be hanging in the same room.

To get comparable fullness in draperies, the fullness is adjusted to allow ½” to 1” difference in spacing between pleats.

Heavy duty zinc pin-on drapery hooks will be inserted 1 ¾” down from the top on pleated draperies.

Covered lead weights are inserted into corners and at seams of sheer draperies at no charge upon workroom discretion.

ALLOWANCE FOR REPEAT

Option 1

- Panel cut length ÷ fabric repeat (in inches) = N (round to the nearest inch)
- N x fabric repeat = new panel cut length
- For example:
 - 108” (cut length) ÷ 26” (repeat) = 4.15” (round up to nearest inch)
 - 5” x 26” = 130” (new cut length) ÷ 36” = 3.6 yards (round up to the nearest half yard)

Option 2

- The first cut is at the cut length, and the other cuts are at the adjusted cut length to allow for the repeat. Just add one less repeat than the width of fabric.
- For example:
 - 3 widths of fabric, add 2 repeats
 - 4 widths of fabric, add 3 repeats
- For example:
 - 4 x 108” (cut length) = 432”
 - 432” + 78” (26” repeat x 3) = 510” ÷ 36” = 14.17 yards (round up to the nearest half yard)

Folding Methods For Shipping

Flat draperies, such as rod pockets, are flat folded.

Pleated draperies are fan folded and carefully packaged in custom-built boxes.

- Pleats are staggered and folds beneath the pleats are aligned, and the panels are snugly wrapped in this position. Crinoline must be “broken” at installation when the panels are dressed.
- At times on large pleated draperies (over 5 widths per panel or over 108” in length) it may be necessary to flat fold the draperies to eliminate the possibility of shipping by truck. Because this method may increase the chance of wrinkling during shipping, please indicate if you do not wish to have your pleated draperies flat folded.

Lined Draperies

Lined draperies are made with a 1 ½” double bottom hem on the lining. Lining will be railroaded when possible.

- The lining is placed under the side hems and blind stitched to the side hem.
- At the heading, lining is turned and folded with the face fabric.
- Face fabric is exposed 4” on the back side of the heading.

Interlined rod pocket draperies or valances should be made with the pocket size ½” larger than normal to allow for extra take up when gathered onto the rod. Please include rod pocket size on the work order as we will not add this allowance.

When **blackout lining** is used, black pigment may show through at the stitch lines in the heading or when tacking pleats.

Unlined Draperies

We will use a single top on unlined drapery orders if we believe it will not affect the appearance of the drapery.

Seaming & Hemming

Side hems are 1 ½” doubled and blind-stitched. Lock stitching may be used on open weaves.

Bottom hems are 4” doubled and blind-stitched.

Multiple widths are joined by surging, which cuts away selvage edges and overlocks the seam.

All seams are hidden behind pleats on pinch pleated draperies. Seams on grommet tops draperies cannot be hidden, but our workroom does their best to place the seam where it will be least visible after installation.

Pattern Matching

All drapery widths are pattern matched, starting at the bottom.

Vertically striped fabrics will be pleated with the stripe falling randomly within the drapery. When vertical stripes require “hand-pleating” to pleat on pattern, please call us for a quote.

Prints, Woven Fabrics, Embroidered Fabrics, Woven Horizontal Stripes, Checks Or Plaids

Our workroom will automatically pattern match from the top down on some prints, wovens, embroidered, all plaids, checks, or woven horizontal stripes. An extra charge per width will be added to your invoice when needed on all orders using these fabrics. We cannot be held responsible if prints, woven, embroidered fabrics, plaids, checks, or woven horizontal stripes do not match at seams. In these fabrics unevenness in warp tensions can cause wavy horizontal lines. This will make the job of matching pattern lines difficult, if not impossible. Specify if you **DO NOT** want to pattern match from the top down. Our workroom will match these fabrics to the best of their ability and DCS will not be responsible for any labor or fabric cost due to these types of fabric issues. If your fabric has horizontal stripes and you want it railroaded so the stripes will run vertically, this must be specified on the work order. Depending on the length of the product, horizontal seaming may be necessary if the cut length is longer than fabric width.

Silk Fabrics

All silk fabrics are inherently woven with flaws, such as slubs, snags, or runs, coming from the vendor and will be used “as is” by our workroom without prior notice. The exception is if there are holes in the fabric. DCS will not be responsible for labor or fabric costs to remake products made from silk fabrics.

Casement Fabrics

Loosely woven casements are extremely sensitive to atmosphere changes and may shrink or stretch in varying weather conditions. DCS will not be responsible for handling or environmental conditions. We suggest draperies made from this type of fabrics be unlined and the finished lengths at least 1” off the floor.

Tolerance

DCS will not be responsible for stretching or shrinkage after the product has left our workroom. Our products are custom-made to your specifications and are measured before shipping. On any treatment made, we will allow up to a 1/2” tolerance in the width or the length of the product. All fabrics are inspected for flaws before cutting. Fabrics with minor defects or characteristic flaws may be used at the workroom’s discretion.

Drape Lengths

FLOOR LENGTH

The drapes are positioned 1/2” off the floor for a more traditional, tailored look. This length is best for traversing drapes. To measure for Floor Length drapes, measure from the bottom of your pole to 1/2” above the floor.

TROUSER LENGTH

The drapes are positioned at floor level. This length is best for stationary drapes. Stationary panels are not recommended to be moved. To measure for Trouser Length drapes, measure from the bottom of your pole to floor level.

PUDDLE LENGTH

The drapes have approximately 6-10” in length added beyond the floor. This length will set off a more dramatic look and is best for stationary panels. Stationary panels are not recommended to be moved. To measure for Puddle Length drapes, measure from the bottom of your pole to the floor. Add 6”-10” to your length, depending on how much you want your drapes to puddle.

Please specify your desired drape length style upon ordering.

Suggested Retail Labor for

Drapes

PRICING

	1 Width	1.5 Width	2.0 Width	2.5 Width	3.0 Width	3.5 Width	4.0 Width	4.5 Width	5.0 Width	5.5 Width	6.0 Width
Grommet	\$84.63	\$141.61	\$152.89	\$185.05	\$201.98	\$228.50	\$251.06	\$271.94	\$300.15	\$315.38	\$349.23
With Single Liner	\$120.74	\$209.31	\$220.60	\$275.32	\$292.25	\$309.17	\$331.74	\$407.34	\$435.55	\$473.35	\$507.20
Tab Top	\$80.11	\$130.61	\$141.89	\$167.56	\$184.49	\$204.52	\$227.09	\$241.47	\$269.68	\$278.43	\$312.28
With Single Liner	\$121.86	\$206.77	\$218.06	\$269.12	\$286.04	\$331.46	\$354.03	\$380.26	\$408.47	\$440.35	\$474.20
Tie Top	\$80.11	\$130.61	\$141.89	\$167.56	\$184.49	\$204.52	\$227.09	\$241.47	\$269.68	\$278.43	\$312.28
With Single Liner	\$121.86	\$206.77	\$218.06	\$269.12	\$286.04	\$331.46	\$354.03	\$380.26	\$408.47	\$440.35	\$474.20
Rod Pocket	\$62.62	\$108.61	\$119.89	\$141.05	\$157.97	\$173.49	\$196.06	\$205.93	\$234.14	\$238.37	\$272.22
With Single Liner	\$111.14	\$161.08	\$172.36	\$211.01	\$227.93	\$260.94	\$283.50	\$310.87	\$339.08	\$360.80	\$394.65
Flat Top	\$62.62	\$108.61	\$119.89	\$141.05	\$157.97	\$173.49	\$196.06	\$205.93	\$234.14	\$238.37	\$272.22
With Single Liner	\$111.14	\$161.08	\$172.36	\$211.01	\$227.93	\$260.94	\$283.50	\$310.87	\$339.08	\$360.80	\$394.65
French / Euro	\$83.50	\$138.23	\$149.51	\$177.72	\$194.64	\$217.21	\$239.78	\$256.71	\$284.91	\$296.20	\$330.05
With Single Liner	\$125.25	\$205.93	\$217.21	\$267.99	\$284.91	\$330.05	\$352.62	\$392.11	\$420.32	\$454.17	\$488.02
Goblet	\$83.50	\$138.23	\$149.51	\$177.72	\$194.64	\$217.21	\$239.78	\$256.71	\$284.91	\$296.20	\$330.05
With Single Liner	\$125.25	\$205.93	\$217.21	\$267.99	\$284.91	\$330.05	\$352.62	\$392.11	\$420.32	\$454.17	\$488.02

Item #	Draperly Extras	Add Per	Retail
EX1301	Interlined	Width	\$12.17
CN0501	Blackout Lined	Width	\$5.27
DR0002E	Finished Length 109" To 118"	Width	\$13.79
DR0002A	Finished Length 119" To 190"	Width	\$19.88
DR0002B	Finished Length 191" To 230"	Width	\$35.70
EX1802	Pattern Match @ Top	Width	\$6.90
EX0203	Luxury fabric upcharge or additional pressing added to base labor on draperies. (Linen, embroidered silks, heavy embroidered fabrics, velvets, suedes.)	Additional 10% added to labor cost	
	Boxing Charges (Draperies)	Per Panel	\$2.03

Item #	Lining	Retail Price Per Yard
L0066	Pinnacle (White)	\$7.12
L0067	Pinnacle (Ivory)	\$7.12
L0017	Classic Napped (White) (Interlining Alternative)	\$11.31
L0018	Classic Napped (Ivory) (Interlining Alternative)	\$11.31
L0011	Blackout Lining (White)	\$7.71

Suggested Retail Labor for

Drapes

PRICING

Grommet cost and # of grommets required for each style of grommet by width.

Finish	#8 - 2 1/2"	#10 - 1 7/16"	#12 - 1 9/16"	#12-Square - 1 9/16"	#15 - 2"	#18 - 2 1/2"	#20 - 3"
Antique Brass	\$2.51	\$3.03	\$1.93	\$7.47	\$2.86	\$4.26	\$5.37
Brass	\$2.51	\$3.03	\$1.93	\$7.47	\$2.86	\$4.26	\$5.37
Black	\$2.76	\$3.69	\$2.26	\$7.47	\$3.23	\$4.91	\$6.07
Antique Copper	\$2.51	\$3.03	\$1.93	\$7.47	\$2.86	\$4.26	\$5.37
Matte Nickel	\$2.51	\$3.03	\$1.93	\$7.47	\$2.86	\$4.26	\$5.37
Nickle	\$2.51	\$3.18	\$2.08	\$7.47	\$2.93	\$4.26	\$5.84

Drapes Size	#8 - 2 1/2"	#10 - 1 7/16"	#12 - 1 9/16"	#12-Square - 1 9/16"	#15 - 2"	#18 - 2 1/2"	#20 - 3"
1 Width	6	6	6	6	6	6	6
1 1/2 Width	12	12	12	12	10	8	8
2 Width	16	16	14	14	12	12	10
2 1/2 Width	18	18	18	18	18	16	16
3 Width	20	20	20	20	20	18	18
3 1/2 Width	22	22	22	22	22	20	20
4 Width	24	24	24	24	24	22	22
4 1/2 Width	26	26	26	26	26	24	24
5 Width	28	28	28	28	28	26	26
5 1/2 Width	30	30	30	30	30	28	28
6 Width	32	32	32	32	32	30	30

Tie-Backs = \$27.50 per pair
 Note: Prices based on max 108 length. Call for pricing beyond 108".



THROW PILLOWS

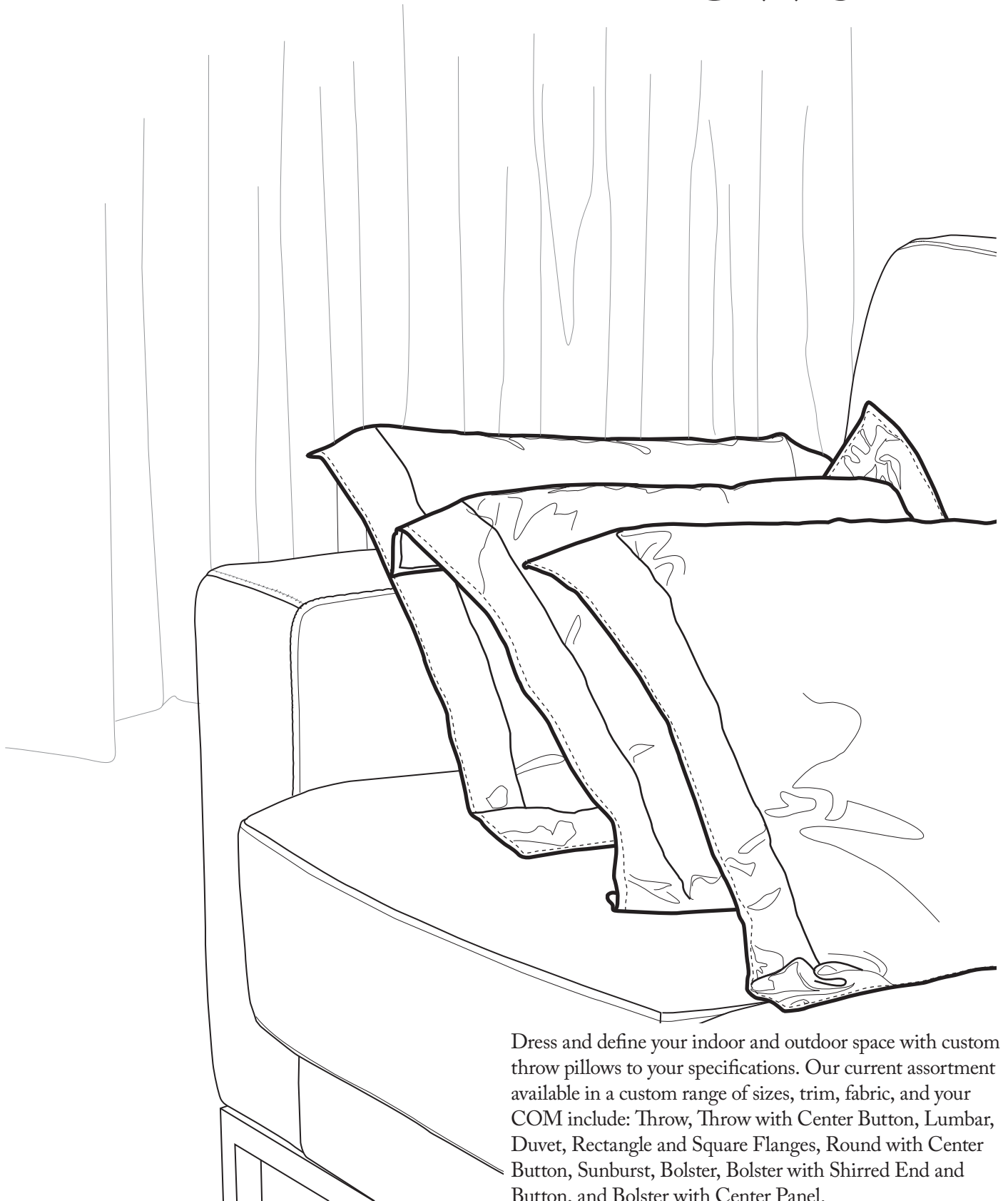

Dress and define your indoor and outdoor space with custom throw pillows to your specifications. Our current assortment available in a custom range of sizes, trim, fabric, and your COM include: Throw, Throw with Center Button, Lumbar, Duvet, Rectangle and Square Flanges, Round with Center Button, Sunburst, Bolster, Bolster with Shirred End and Button, and Bolster with Center Panel.

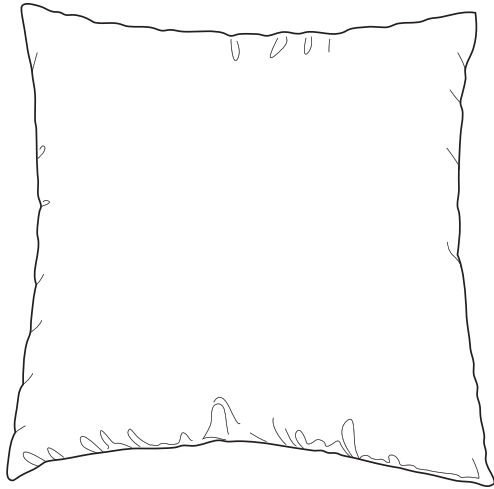

Throw Pillow

SIZES

- 12"–34" H x 12"–34" W

OPTIONS

- Fabric Options
 - Front fabric
 - Back fabric
 - Cording fabric
- Edge Options
 - Knife edge
 - Fabric cording (standard size is ¼")
 - Braid
 - Fringe
- Zipper Options
 - Standard nylon invisible zipper
 - 3 Colors: beige, white or black
- Fill Options
 - Feather bun (90% feather/10% down)
 - Poly bun
 - Direct Fill

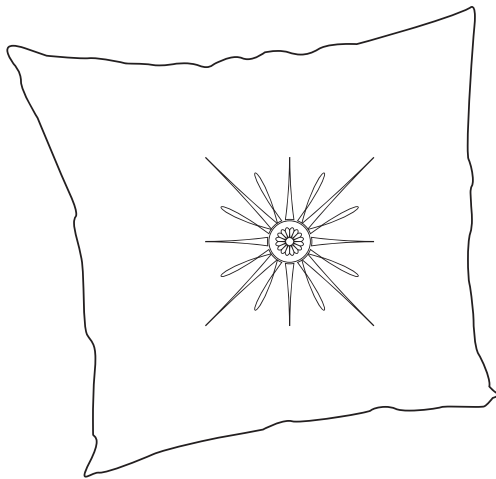

Throw Pillow with Center Button

SIZES

- 12"–30" H x 12"–30" W

OPTIONS

- Fabric Options
 - One fabric for entire pillow
 - Cording and button fabric (same used for both)
- Edge Options
 - Knife edge
 - Comes standard with ¼" fabric cording
- Buttons
 - Covered 1" button on each side.
 - Only style available with COM button option
 - » 1 button each side
- Zipper Options
 - No zipper. This pillow is sewn shut.
- Fill Options
 - Feather bun (90% feather/10% down)
 - Poly bun



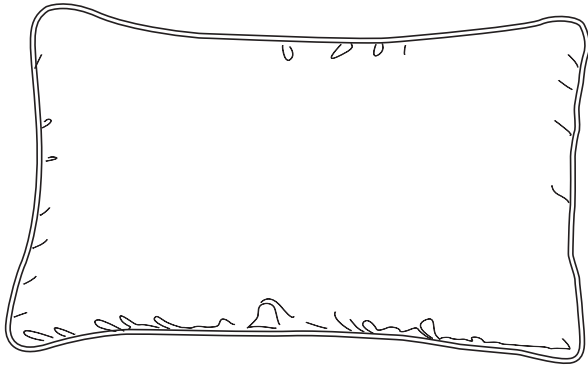

Lumbar Pillow

SIZES

- 8"-12" H x 12"-30" W

OPTIONS

- Fabric Options
 - Front fabric
 - Back fabric
 - Cording fabric
- Edge Options
 - Knife edge
 - Fabric cording (standard size is ¼")
 - Braid
 - Fringe
- Zipper Options
 - Standard nylon invisible zipper
 - 3 Colors: beige, white or black
- Fill Options
 - Feather bun (90% feather/10% down)
 - Poly bun
 - Direct Fill

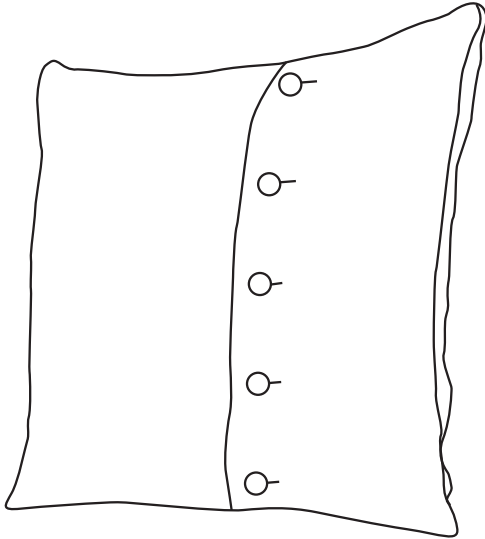

Duvet Pillow

SIZES

- 18"-24" W x 18"-24" H

OPTIONS

- Fabric Options
 - One fabric option for front and back panels
 - Working duvet flap fabric
 - » Width of flap is ½ of overall pillow size.
 - Cording and button fabric (same used for both)
- Edge Options
 - Knife edge
 - Comes standard with ¼" fabric cording
- Buttons
 - (5) Covered 1" buttons
- Zipper Options
 - Working duvet opening. No zipper available.
- Fill Options
 - Feather bun (90% feather/10% down)
 - Poly bun



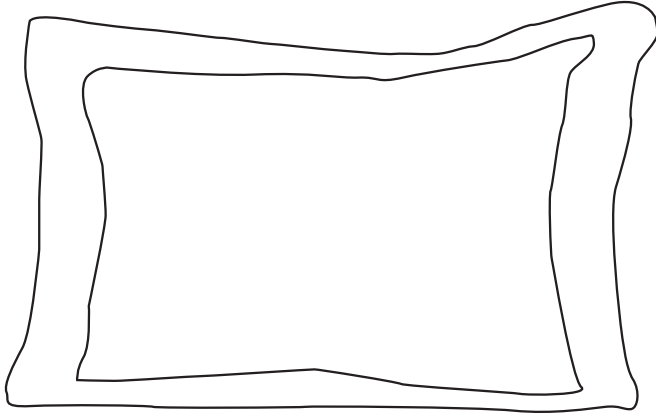

Rectangle Flange Pillow

SIZES

- 12"-30" H x 12"-30" W

OPTIONS

- Fabric Options
 - One fabric option for the entire pillow.
- Edge Options
 - 12" sq.-18" sq. pillow body: Standard 2" flange
 - 20" sq.-30" sq. pillow body: Standard 2 ½" flange
- Zipper Options
 - Standard nylon invisible zipper
 - 3 Colors: beige, white or black
- Fill Options
 - Feather bun (90% feather/10% down)
 - Poly bun

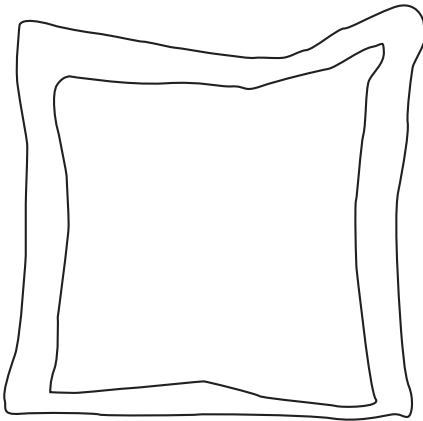

Square Flange Pillow

SIZES

- 12" sq.-30" sq.

OPTIONS

- Fabric Options
 - One fabric option for the entire pillow.
- Edge Options
 - 12" sq.-18" sq. pillow body: Standard 2" flange
 - 20" sq.-30" sq. pillow body: Standard 2 ½" flange
- Zipper Options
 - Standard nylon invisible zipper
 - 3 Colors: beige, white or black
- Fill Options
 - Feather bun (90% feather/10% down)
 - Poly bun



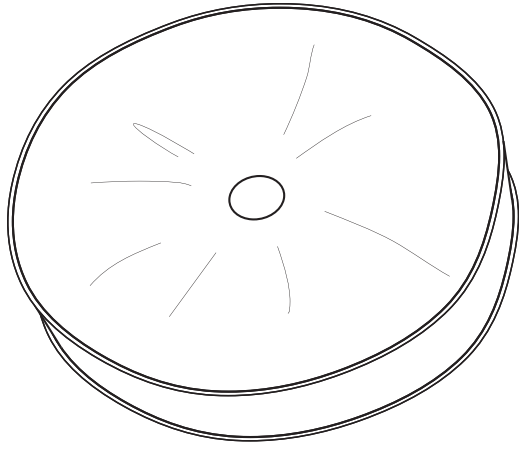

Boxed Round with Center Button

SIZES

- 16", 18" and 20"
- 2" Thickness

OPTIONS

- Fabric Options
 - Fabric option for entire pillow body
 - Cording and button fabric (same used for both)
- Edge Options
 - Box edge
 - Comes standard with ¼" fabric cording
- Buttons
 - Covered 1" button
- Zipper Options
 - No zipper. Pillow is sewn shut.
- Fill Options
 - Feather bun (90% feather/10% down)
 - Poly bun

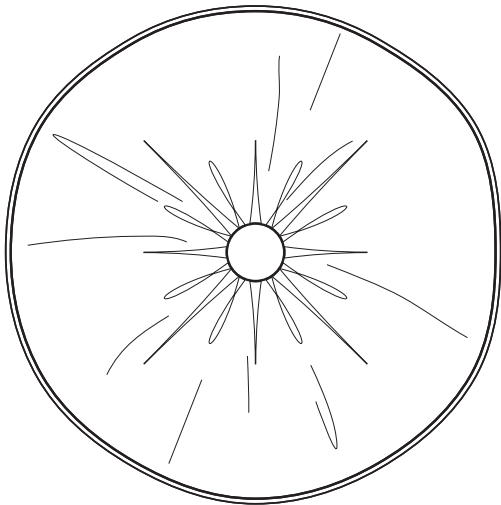

Round Sunburst with Center Button

SIZES

- 16", 18" and 20"

OPTIONS

- Fabric Options
 - Fabric option for entire pillow body (solid fabrics only)
 - Cording and button fabric (same used for both) (solid fabrics only)
- Edge Options
 - Knife edge
 - Comes standard with ¼" fabric cording
- Buttons
 - Covered 2" button
- Zipper Options
 - No zipper. Pillow is sewn shut.
- Fill Options
 - Feather bun (90% feather/10% down)
 - Poly bun



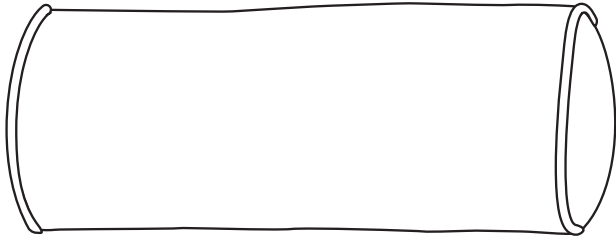

Bolster

SIZES AVAILABLE

- 10–36” L x 6–12” D

OPTIONS

- Fabric Options
 - Main fabric
 - Side panel fabric
 - Cording fabric
- Edge Options
 - Fabric cording (standard size is ¼”)
- Zipper Options
 - Standard nylon invisible zipper
 - 3 Colors: beige, white or black
- Fill Options
 - Foam

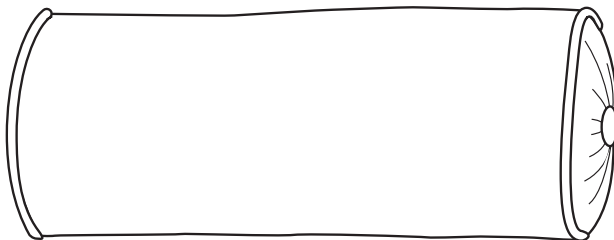

Bolster with Shirred End and Covered Buttons

SIZES AVAILABLE

- 10–36” L x 6–12” D

OPTIONS

- Fabric Options
 - Main fabric
 - End panels same as main fabric
 - Cording and button fabric (same used for both)
- Edge Options
 - Fabric cording (standard size is ¼”)
- Button Options
 - Covered 1” button on each end.
- Zipper Options
 - No zipper. Pillow is sewn shut.
- Fill Options
 - Foam



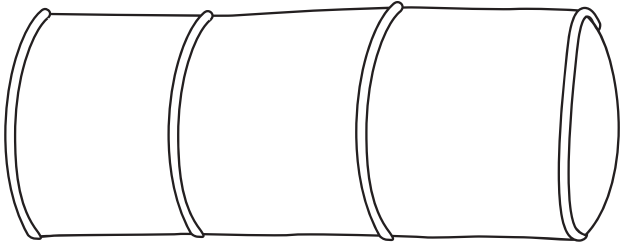

Bolster with Contrasting Center Panel

SIZES AVAILABLE

- 10–36" L x 6–12" D

OPTIONS

- Fabric Options
 - Main fabric
 - Center panel and cording fabrics are the same.
 - » Center panel width is $\frac{1}{3}$ of overall pillow size.
 - Side panel fabric same as main fabric.
- Edge Options
 - Fabric cording (standard size is $\frac{1}{4}$ ")
- Zipper Options
 - Standard nylon invisible zipper
 - 3 Colors: beige, white or black
- Fill Options
 - Foam





THROW PILLOW STANDARDS

Standard Pillow Allowances

ROUND OR SQUARE PILLOW

- Pillow body width + 1 1/2" = cut width ÷ the fabric width = # of cuts needed
- Pillow body length + 1 1/2" = cut length = # of cuts needed (x cut length ÷ 36" = yardage estimate)
- Round up to the nearest 1/2 yard.

FLANGE PILLOWS

- Pillow body width + 2" or 2 1/2" flange + 1 1/2" = cut width ÷ the fabric width = # of cuts needed
- Pillow body length + 2" or 2 1/2" flange + 1 1/2" = cut length = # of cuts needed (x cut length ÷ 36" = yardage estimate)
- Round up to the nearest 1/2 yard.

Options Offered

C.O.M. AVAILABILITY

- Pillow fabrics
- Cording fabrics
- Button fabrics
- Button (specialty, i.e. vintage)
- Fringe

INVISIBLE ZIPPER (Standard as offered.)

- White
- Cream
- Black

EDGE OPTIONS

- Knife Edge
 - **Trim Allowances:** Add together all four sides of pillow + 10" easement ÷ 36" for total yardage.
- Flange
- Fabric Cording: Standard size is 1/4", while 1/2" and 1" are also available.
 - **Cording Allowances:** Bias Cut Yardage: Cording fabric is cut on the bias (diagonal) when it is used to cover cording. The bias has a slight natural stretch that allows fabric to ease around bends and curves without puckering. The longest center cuts are used first to avoid seaming.

The Bias Yardage Chart below provides you with the total inches of bias cut yardage yielded from ONE YARD of fabric. The minimum yardage we can use to make suitable bias cuts is 1/2 yard. First find total inches of cording required and size of cording required.

Finished Size of Cord	Bias Cut Width Size
1/4"	2" cuts
1/2"	3 1/2" cuts
1"	5" cuts

BIAS CUT YARDAGE CHART - 54" wide fabric	
Bias Cut Width	Total inches yielded in 1 yard
2" cut size	570 total inches
3 1/3" cut size	490 total inches
4" cut size	375 total inches
5" cut size	277 total inches
6" cut size	258 total inches
9" cut size	154 total inches

PRICING & YARDAGE

How to Calculate Retail Labor Price

Length + Width / 2 x Retail Labor Rate

Please refer to the right-side charts for the below examples.

FOAM EXAMPLE

- Diameter x 3.14 + length ÷ 2 x \$2.81 = Retail Labor Rate
- Example – 6” x 24” bolster with foam:
6” diameter x 3.14 = 18.84 + 24 length ÷ 2 x \$2.81 = \$60.19

POLY BUN EXAMPLE

- Example – 6” x 24” bolster with poly bun:
6” diameter x 3.14 = 18.84 + 24” length ÷ 2 x \$3.61 = \$77.33

Fabric Yardage Requirements

- Up to 24”: Send 1 yard
- 25” and over:
 - 1 ½ yards solid fabric
 - 2 yards print fabric

Square and Rectangle Pillows	
Pillow Options	Retail Labor Rate Per Inch
Knife Edge Direct Fill	\$2.45
Knife Edge Poly Bun	\$3.27
Knife Edge Down Insert	\$3.91
Trim Direct Fill	\$2.78
Trim Poly Bun	\$3.61
Trim Down Insert	\$4.25
Flange Pillow	
Pillow Options	Retail Labor Rate Per Inch
Poly Bun	\$4.06
Down Insert	\$4.70
Duvet Pillow	
Pillow Options	Retail Labor Rate Per Inch
Poly Bun	\$4.72
Down Insert	\$5.36
Sunburst Pillow	
Pillow Options	Retail Labor Rate Per Inch
Poly Bun	\$3.69
Down Insert	\$4.33
Round Pillow (With Boxing or With Boxing and Button)	
Pillow Options	Retail Labor Rate Per Inch
Poly Bun	\$3.75
Down Insert	\$4.39
Bolster Pillow	
Pillow Options	Retail Labor Rate Per Inch
Foam	\$2.81
Poly Bun	\$3.61



UMBRELLAS

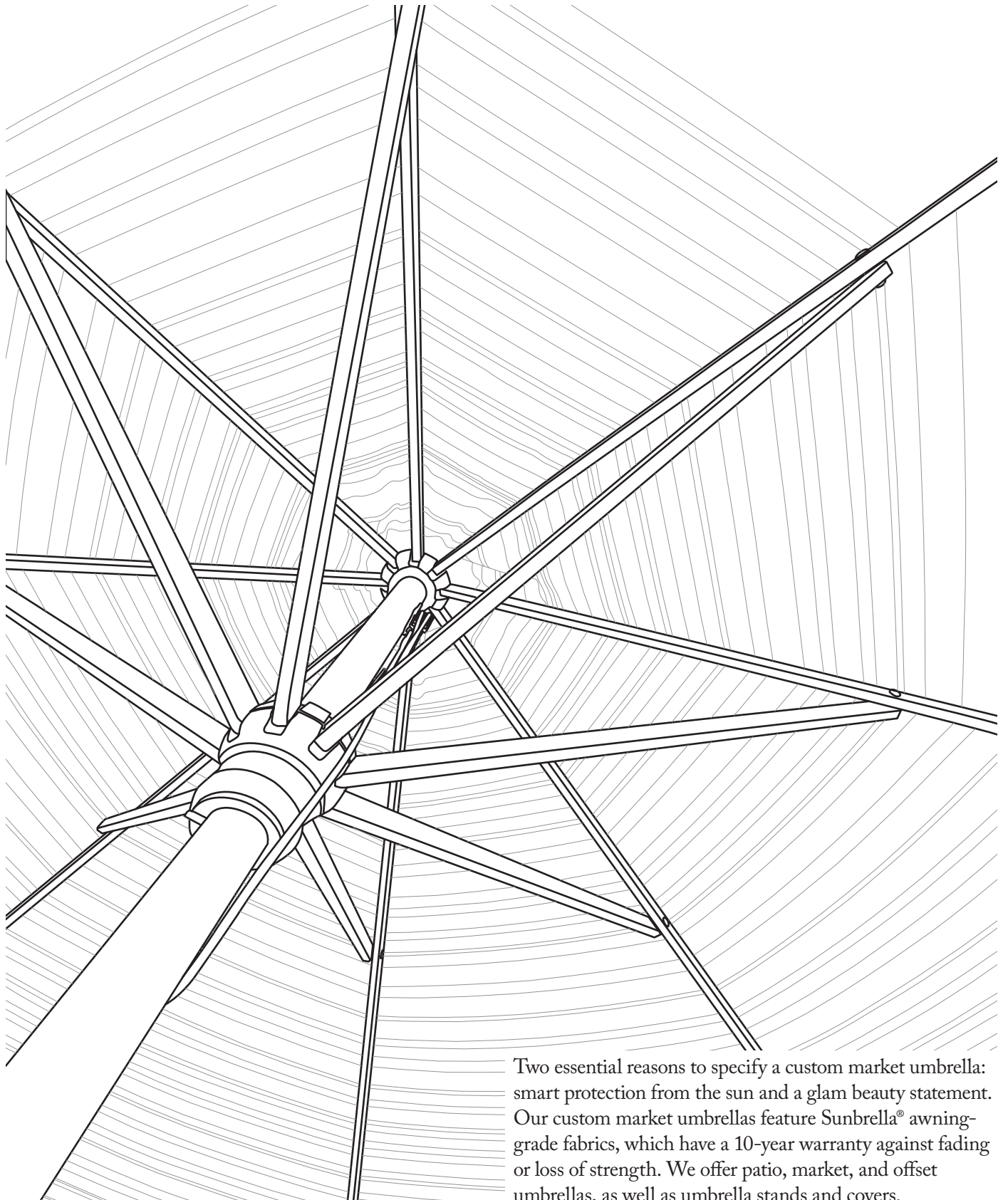

Two essential reasons to specify a custom market umbrella: smart protection from the sun and a glam beauty statement. Our custom market umbrellas feature Sunbrella® awning-grade fabrics, which have a 10-year warranty against fading or loss of strength. We offer patio, market, and offset umbrellas, as well as umbrella stands and covers.

Quick Features

- 6.5' Canopy Span
- 4 Panel Square
- Double Pulley Opening System
- Aluminum Pole
- Fiberglass Ribs
- 1 ½" Pole Diameter
- 2mm Pole Thickness
- No Tilt
- Sunbrella® or Outdura® Canopy
- Logo Option



6.5' SQUARE ALUMINUM MARKET UMBRELLA

This **6.5' SQUARE ALUMINUM MARKET UMBRELLA** is a quality umbrella with a canopy made using your choice of Sunbrella® fabric or Outdura® fabric — covered by a 5-10 year warranty*. This fabric is known for its durability against the elements and its high resistance to staining and fading. While customizing this umbrella, the Alternating Fabric Option will allow you to choose a different fabric for the alternating panels.

Do you need a logo printed on your umbrella? You have the capability of adding a logo to this umbrella on 1 to 4 panels.

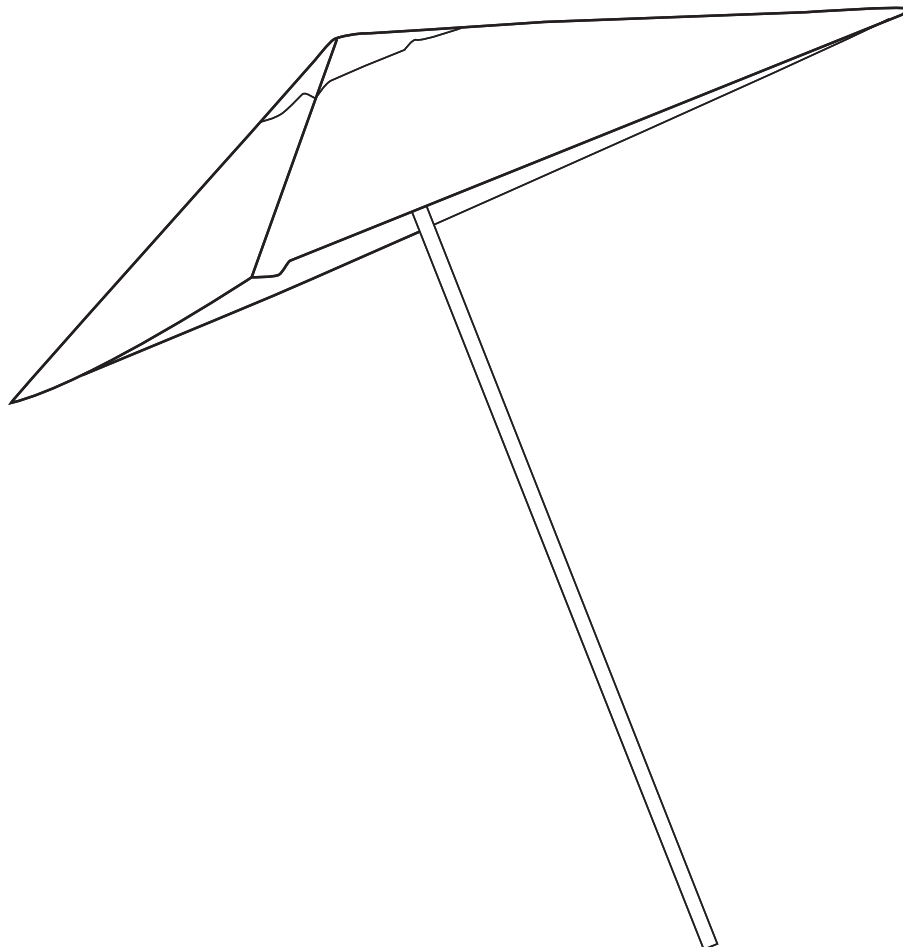

Choose Options

A. POLE COLOR

- Black
- Champagne
- White

B. POLE HEIGHT

- Standard
- Bar height

C. CANOPY FABRIC

- Single
- Alternating

D. VENT OPTION

- Single
- Double

E. TOP VENT FABRIC

- Match main fabric
- Match alternate fabric
- Different fabric

F. VALANCE

- No valance
- Add valance

G. LOGO PRINTING

- No logo
- Single color
- Multicolor
- Inkjet acrylic

Logo Printing Options

- **Single Color** (for basic logos and text)
- **Multicolor** (superb color matching and blending in photographic quality)
- **Inkjet Acrylic** (for projects requiring the entire panel be printed or where you require Pantone Matching System color accuracy for your fabric color).

To customize your umbrella, please select all choice options before adding to cart.

Logo Umbrella Orders

Order your umbrella as normal. Choose all options you would like to include with your umbrella. After your Logo Umbrella order is placed, a customer service representative will contact you within one business day with instructions on where to upload your logo. A proof will be submitted to you for approval with exact logo and/or text placement. When approved, the printing process will begin.

*Sunbrella® Awning Grade fabrics feature a 10-year warranty against staining and fading. Sunbrella® Furniture Grade fabrics feature a 5-year warranty against staining and fading. Outdura® fabric features a 5-year warranty against staining and fading. **This warranty does not cover normal care and cleaning or damage from misuse or abuse.**

Product Specifications

ASSEMBLED DIMENSIONS

92" × 78" × 78"

SHIPPING DIMENSIONS

68" × 8" × 8"

SHIPPING WEIGHT

35 lbs.

ASSEMBLY

This product ships unassembled and will require easy and straight-forward assembly using common household tools. Detailed instructions are included.

Note: See our Umbrella Standards in the back of this section for details on our Delivery for Quotes, Return Policy, Shipping and Warranty information.

Pricing

Please call **1.800.510.8325** for a quote or visit **DesignerCustomSource.com** for instant pricing.

Quick Features

- 7.5' Canopy Span
- 8 Panel Octagon
- Pulley Opening System
- Hardwood Pole
- Hardwood Ribs
- 1 ½" Pole Diameter
- 1.85mm Pole Thickness
- No Tilt
- Sunbrella® or Outdura® Canopy
- Logo Option

7.5' WOOD MARKET UMBRELLA

WITH PULLEY AND NO TILT



This **7.5' WOOD MARKET UMBRELLA** is perfect for smaller backyard applications. This market umbrella features stained cherry wood, an eight-panel canopy and a draw-string pulley opening system. This umbrella does not include the tilt option.

The canopy of this wood market umbrella is made using your choice of Sunbrella® fabric or Outdura® fabric — covered by a 5-10 year warranty*. This fabric is known for its durability against the elements and its high resistance to staining and fading. While customizing this umbrella, the Alternating Fabric Option will allow you to choose a different fabric for the alternating panels.

Do you need a logo printed on your umbrella? You have the capability of adding a logo to this umbrella on 1 to 8 panels.

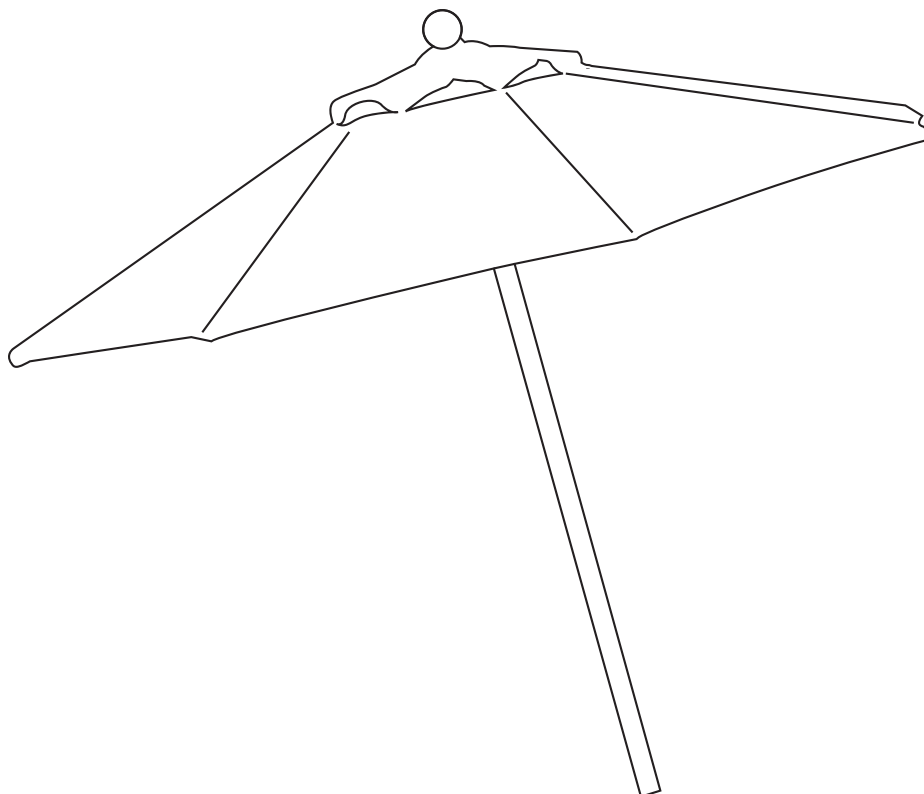

Choose Options

A. CANOPY FABRIC

- Single
- Alternating

B. VENT OPTION

- Single
- Double

C. TOP VENT FABRIC

- Match main fabric
- Match alternate fabric
- Different fabric

D. VALANCE

- No valance
- Add valance

E. LOGO PRINTING

- No logo
- Single color
- Multicolor
- Inkjet acrylic

Logo Printing Options

- **Single Color** (for basic logos and text)
- **Multicolor** (superb color matching and blending in photographic quality)
- **Inkjet Acrylic** (for projects requiring the entire panel be printed or where you require Pantone Matching System color accuracy for your fabric color).

To customize your umbrella, please select all choice options before adding to cart.

Logo Umbrella Orders

Order your umbrella as normal. Choose all options you would like to include with your umbrella. After your Logo Umbrella order is placed, a customer service representative will contact you within one business day with instructions on where to upload your logo. A proof will be submitted to you for approval with exact logo and/or text placement. When approved, the printing process will begin.

*Sunbrella® Awning Grade fabrics feature a 10-year warranty against staining and fading. Sunbrella® Furniture Grade fabrics feature a 5-year warranty against staining and fading. Outdura® fabric features a 5-year warranty against staining and fading. **This warranty does not cover normal care and cleaning or damage from misuse or abuse.**

Product Specifications

ASSEMBLED DIMENSIONS

92" × 90" × 90"

SHIPPING DIMENSIONS

48" × 8" × 8"

SHIPPING WEIGHT

30 lbs.

ADDITIONAL INFORMATION

Height: 92" (standard)

Pole diameter: 1 3/8"

ASSEMBLY

This product ships as a complete unit and does not require any assembly upon receipt.

Note: See our Umbrella Standards in the back of this section for details on our Delivery for Quotes, Return Policy, Shipping and Warranty information.

Pricing

Please call **1.800.510.8325** for a quote or visit **DesignerCustomSource.com** for instant pricing.

Quick Features

- 9' Canopy Span
- 8 Panel Octagon
- Crank Opening System
- Aluminum Pole
- Fiberglass Ribs
- 1 ½" Pole Diameter
- 2mm Pole Thickness
- Automatic Tilt
- Sunbrella® or Outdura® Canopy
- Logo Option



9' ALUMINUM MARKET UMBRELLA

WITH FIBERGLASS RIBS AND CRANK

This 9' ALUMINUM MARKET UMBRELLA WITH FIBERGLASS RIBS AND CRANK features a crank, auto tilt and comes with your choice of a white, black or champagne frame. This market umbrella, with an eight-panel canopy, features an extra crown of fabric at the top, which is called a wind vent. This practical design allows for temporary gusts of wind to escape from underneath the umbrella cover.

The canopy of this aluminum market umbrella is made using your choice of Sunbrella® fabric or Outdura® fabric — covered by a 5-10 year warranty*. This fabric is known for its durability against the elements and its high resistance to staining and fading. While customizing this umbrella, the Alternating Fabric Option will allow you to choose a different fabric for the alternating panels.

Do you need a logo printed on your umbrella? You have the capability of adding a logo to this umbrella on 1 to 8 panels.



Choose Options

A. POLE COLOR

- Black
- Champagne
- White

B. POLE HEIGHT

- Standard
- Bar height

C. CANOPY FABRIC

- Single
- Alternating

D. VENT OPTION

- Single
- Double

E. TOP VENT FABRIC

- Match main fabric
- Match alternate fabric
- Different fabric

F. VALANCE

- No valance
- Add valance

G. LOGO PRINTING

- No logo
- Single color
- Multicolor
- Inkjet acrylic

Logo Printing Options

- **Single Color** (for basic logos and text)
- **Multicolor** (superb color matching and blending in photographic quality)
- **Inkjet Acrylic** (for projects requiring the entire panel be printed or where you require Pantone Matching System color accuracy for your fabric color).

To customize your umbrella, please select all choice options before adding to cart.

Logo Umbrella Orders

Order your umbrella as normal. Choose all options you would like to include with your umbrella. After your Logo Umbrella order is placed, a customer service representative will contact you within one business day with instructions on where to upload your logo. A proof will be submitted to you for approval with exact logo and/or text placement. When approved, the printing process will begin.

*Sunbrella® Awning Grade fabrics feature a 10-year warranty against staining and fading. Sunbrella® Furniture Grade fabrics feature a 5-year warranty against staining and fading. Outdura® fabric features a 5-year warranty against staining and fading. **This warranty does not cover normal care and cleaning or damage from misuse or abuse.**

Product Specifications

ASSEMBLED DIMENSIONS

72" × 108" × 108"

SHIPPING DIMENSIONS

68" × 8" × 8"

SHIPPING WEIGHT

29 lbs.

ASSEMBLY

This product ships unassembled and will require easy and straight-forward assembly using common household tools. Detailed instructions are included.

Note: See our Umbrella Standards in the back of this section for details on our Delivery for Quotes, Return Policy, Shipping and Warranty information.

Pricing

Please call **1.800.510.8325** for a quote or visit **DesignerCustomSource.com** for instant pricing.

Quick Features

- 9' Canopy Span
- 8 Panel Octagon
- Pulley System
- Hardwood Pole
- Hardwood Ribs
- 1 ½" Pole Diameter
- No Tilt
- Sunbrella® or Outdura® Canopy
- Logo Option

9' WOOD MARKET UMBRELLA

WITH NO TILT



This **9' WOOD MARKET UMBRELLA** works well in larger residential or commercial applications. This market umbrella features stained cherry wood, an eight-panel canopy and a drawstring pulley opening system. This umbrella does not feature the tilt option.

Market umbrellas feature an extra crown of fabric at the top, which is called a wind vent. This practical design allows for temporary gusts of wind to escape from underneath the umbrella cover.

The 9 ft. Commercial Market Umbrella features a canopy made using your choice of Sunbrella® fabric or Outdura® fabric — covered by a 5-10 year warranty*. This fabric is known for its durability against the elements and its high resistance to staining and fading. While customizing this umbrella, the Alternating Fabric Option will allow you to choose a different fabric for the alternating panels.

Do you need a logo printed on your umbrella? You have the capability of adding a logo to this umbrella on 1 to 8 panels.

Choose Options

A. CANOPY FABRIC

- Single
- Alternating

B. VENT OPTION

- Single
- Double

C. TOP VENT FABRIC

- Match main fabric
- Match alternate fabric
- Different fabric

D. VALANCE

- No valance
- Add valance

E. LOGO PRINTING

- No logo
- Single color
- Multicolor
- Inkjet acrylic

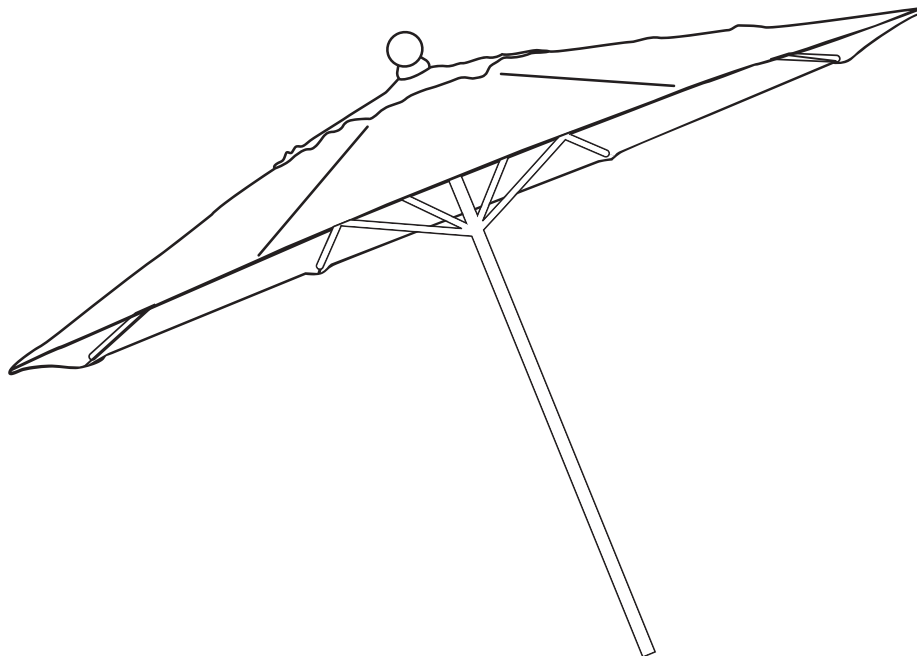

Logo Printing Options

- **Single Color** (for basic logos and text)
- **Multicolor** (superb color matching and blending in photographic quality)
- **Inkjet Acrylic** (for projects requiring the entire panel be printed or where you require Pantone Matching System color accuracy for your fabric color).

To customize your umbrella, please select all choice options before adding to cart.

Logo Umbrella Orders

Order your umbrella as normal. Choose all options you would like to include with your umbrella. After your Logo Umbrella order is placed, a customer service representative will contact you within one business day with instructions on where to upload your logo. A proof will be submitted to you for approval with exact logo and/or text placement. When approved, the printing process will begin.

*Sunbrella® Awning Grade fabrics feature a 10-year warranty against staining and fading. Sunbrella® Furniture Grade fabrics feature a 5-year warranty against staining and fading. Outdura® fabric features a 5-year warranty against staining and fading. **This warranty does not cover normal care and cleaning or damage from misuse or abuse.**

Product Specifications

ASSEMBLED DIMENSIONS

98" × 108" × 108"

SHIPPING DIMENSIONS

68" × 8" × 8"

SHIPPING WEIGHT

29 lbs.

ADDITIONAL INFORMATION

Height: 92" (standard)

Pole diameter: 1 3/8"

ASSEMBLY

This product ships as a complete unit and does not require any assembly upon receipt.

Note: See our Umbrella Standards in the back of this section for details on our Delivery for Quotes, Return Policy, Shipping and Warranty information.

Pricing

Please call **1.800.510.8325** for a quote or visit **DesignerCustomSource.com** for instant pricing.

Quick Features

- 7.5' Canopy Span
- 8 Panel Octagonal Canopy
- Crank Opening System
- Aluminum Pole
- Fiberglass Ribs
- 1 ½" Pole Diameter
- 2mm Pole Thickness
- Automatic Tilt
- Sunbrella® or Outdura® Canopy
- Logo Option

7.5' ALUMINUM PATIO UMBRELLA

WITH FIBERGLASS RIBS AND CRANK



This 7.5' COMMERCIAL ALUMINUM PATIO UMBRELLA WITH FIBERGLASS RIBS is a quality umbrella with three pole color options. The 7.5' Commercial Patio Umbrella features a crank, auto-tilt and a canopy made using your choice of Sunbrella® fabric or Outdura® fabric — covered by a 5-10 year warranty*. This fabric is known for its durability against the elements and its high resistance to staining and fading. While customizing this umbrella, the Alternating Fabric Option will allow you to choose a different fabric for the alternating panels.

Do you need a logo printed on your umbrella? You have the capability of adding a logo to this umbrella on 1 to 8 panels. Valance printing is also an option at no additional cost for the panels with a logo added.

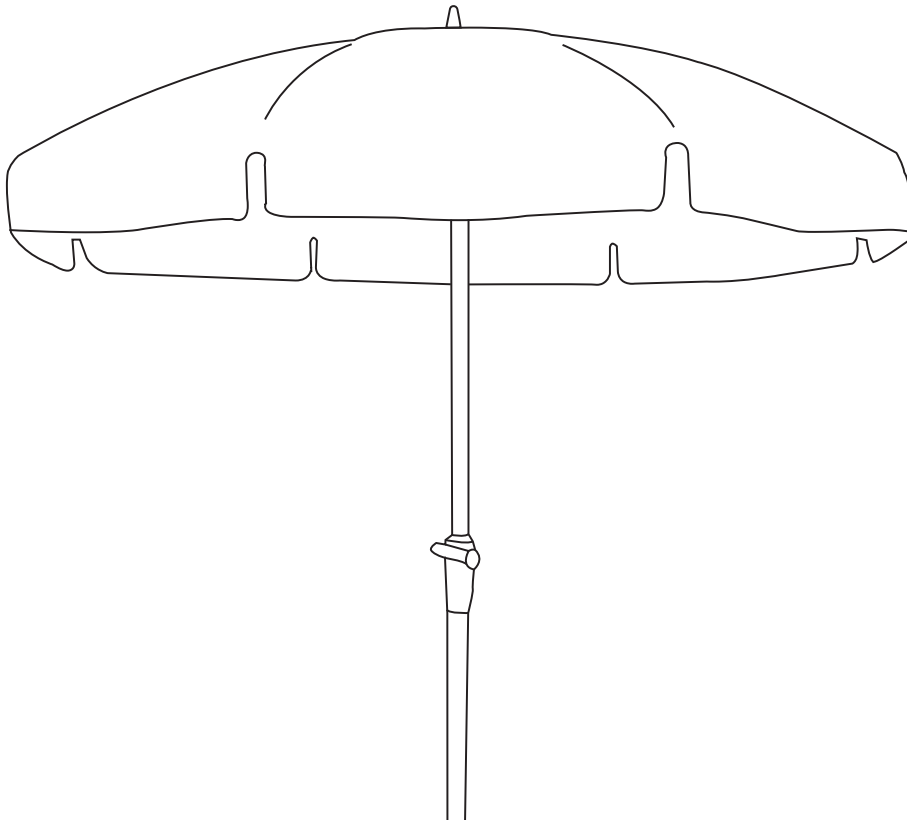

Choose Options

A. POLE COLOR

- Black
- Champagne
- White

B. POLE HEIGHT

- Standard
- Bar height

C. CANOPY FABRIC

- Single
- Alternating

D. MAIN FABRIC

E. TRIM COLOR

F. LOGO PRINTING

- No logo
- Single color
- Multicolor
- Inkjet acrylic

Logo Printing Options

- **Single Color** (for basic logos and text)
- **Multicolor** (superb color matching and blending in photographic quality)
- **Inkjet Acrylic** (for projects requiring the entire panel be printed or where you require Pantone Matching System color accuracy for your fabric color).

To customize your umbrella, please select all choice options before adding to cart.

Logo Umbrella Orders

Order your umbrella as normal. Choose all options you would like to include with your umbrella. After your Logo Umbrella order is placed, a customer service representative will contact you within one business day with instructions on where to upload your logo. A proof will be submitted to you for approval with exact logo and/or text placement. When approved, the printing process will begin.

*Sunbrella® Awning Grade fabrics feature a 10-year warranty against staining and fading. Sunbrella® Furniture Grade fabrics feature a 5-year warranty against staining and fading. Outdura® fabric features a 5-year warranty against staining and fading. **This warranty does not cover normal care and cleaning or damage from misuse or abuse.**

Product Specifications

ASSEMBLED DIMENSIONS

92" × 90" × 90"

SHIPPING DIMENSIONS

68" × 8" × 8"

SHIPPING WEIGHT

28 lbs.

ASSEMBLY

This product ships unassembled and will require easy and straight-forward assembly using common household tools. Detailed instructions are included.

Note: See our Umbrella Standards in the back of this section for details on our Delivery for Quotes, Return Policy, Shipping and Warranty information.

Pricing

Please call **1.800.510.8325** for a quote or visit **DesignerCustomSource.com** for instant pricing.

Quick Features

- 8.5' Canopy span
- 12 Panels
- Crank opening system
- Aluminum pole
- Steel ribs
- Manual tilt
- Sunbrella® or Outdura® canopy
- Alternating fabric option

8.5' ALUMINUM PATIO UMBRELLA

WITH STEEL RIBS, CRANK AND MANUAL TILT



This **8.5' ALUMINUM CRANK PATIO UMBRELLA WITH STEEL RIBS AND MANUAL TILT** would look great on your patio or deck. This patio umbrella has 12 canopy panels and opens via crank.

Our patio umbrellas are made using Sunbrella® fabric or Outdura® fabric — covered by a 5-10 year warranty*. This fabric is known for its durability against the elements and its high resistance to staining and fading. While customizing this umbrella, the Alternating Fabric Option will allow you to choose a different fabric for the alternating panels.

Do you need a logo printed on your umbrella? You have the capability of adding a logo to this umbrella on 1 to 12 panels. Valance printing is also an option at no additional cost for the panels with a logo added.

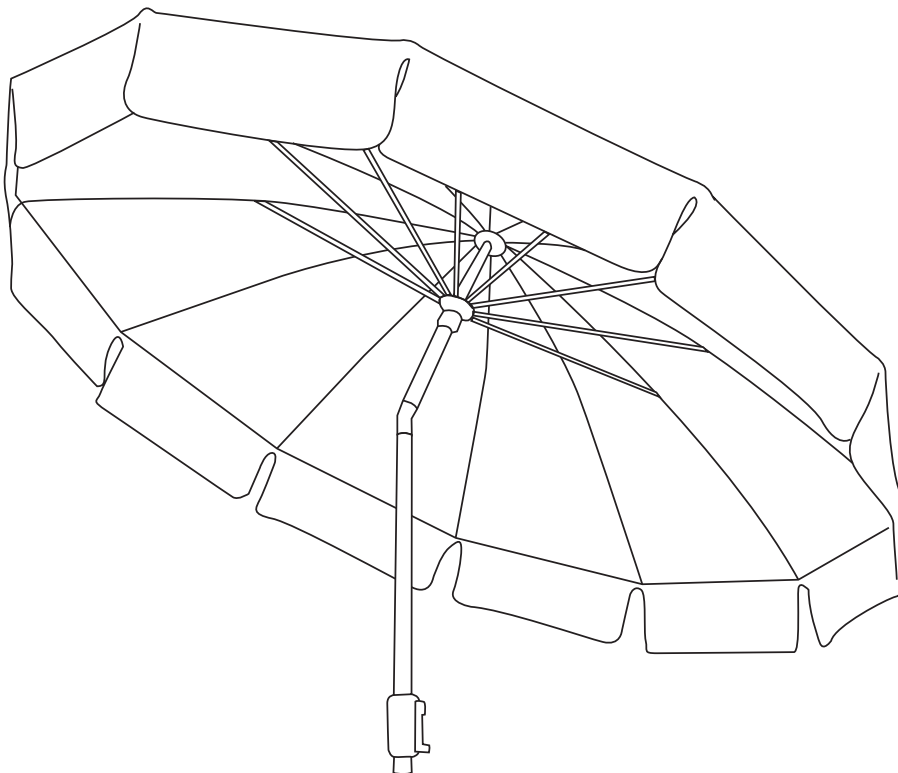

Choose Options

A. POLE COLOR

- Black
- Champagne
- White

B. POLE HEIGHT

- Standard
- Bar height

C. CANOPY FABRIC

- Single
- Alternating

D. MAIN FABRIC

E. TRIM COLOR

F. LOGO PRINTING

- No logo
- Single color
- Multicolor
- Inkjet acrylic

Logo Printing Options

- **Single Color** (for basic logos and text)
- **Multicolor** (superb color matching and blending in photographic quality)
- **Inkjet Acrylic** (for projects requiring the entire panel be printed or where you require Pantone Matching System color accuracy for your fabric color).

To customize your umbrella, please select all choice options before adding to cart.

Logo Umbrella Orders

Order your umbrella as normal. Choose all options you would like to include with your umbrella. After your Logo Umbrella order is placed, a customer service representative will contact you within one business day with instructions on where to upload your logo. A proof will be submitted to you for approval with exact logo and/or text placement. When approved, the printing process will begin.

*Sunbrella® Awning Grade fabrics feature a 10-year warranty against staining and fading. Sunbrella® Furniture Grade fabrics feature a 5-year warranty against staining and fading. Outdura® fabric features a 5-year warranty against staining and fading. **This warranty does not cover normal care and cleaning or damage from misuse or abuse.**

Product Specifications

ASSEMBLED DIMENSIONS

92" × 102" × 102"

SHIPPING DIMENSIONS

63" × 10" × 10"

SHIPPING WEIGHT

30 lbs.

ASSEMBLY

This product ships unassembled and will require easy and straight-forward assembly using common household tools. Detailed instructions are included.

Note: See our Umbrella Standards in the back of this section for details on our Delivery for Quotes, Return Policy, Shipping and Warranty information.

Pricing

Please call **1.800.510.8325** for a quote or visit **DesignerCustomSource.com** for instant pricing.

Quick Features

- 7.5' Canopy span
- 8 Panel octagon
- Hardwood pole
- Fiberglass ribs
- 1 ½" Pole diameter
- 1.85mm Pole thickness
- No tilt
- Pointed bottom pole
- Sunbrella® or Outdura® canopy
- Logo Option



7.5' POP-UP WOOD BEACH UMBRELLA

WITH FIBERGLASS RIBS

This **7.5' POP-UP WOOD BEACH UMBRELLA** has white fiberglass ribs and a disassemble button. This beach umbrella features the push button pop-up opening system, which functions like a handheld umbrella. If you would not like the pop-up with button, please choose the option before checkout. This umbrella comes with a spiked pole to easily set in the sand.

The canopy of this wood beach umbrella is made using your choice of Sunbrella® fabric or Outdura® fabric — covered by a 5-10 year warranty*. This fabric is known for its durability against the elements and its high resistance to staining and fading. While customizing this umbrella, the Alternating Fabric Option will allow you to choose a different fabric for the alternating panels.

Do you need a logo printed on your umbrella? You have the capability of adding a logo to this umbrella on 1 to 8 panels. Valance printing is also an option at no additional cost for the panels with a logo added.

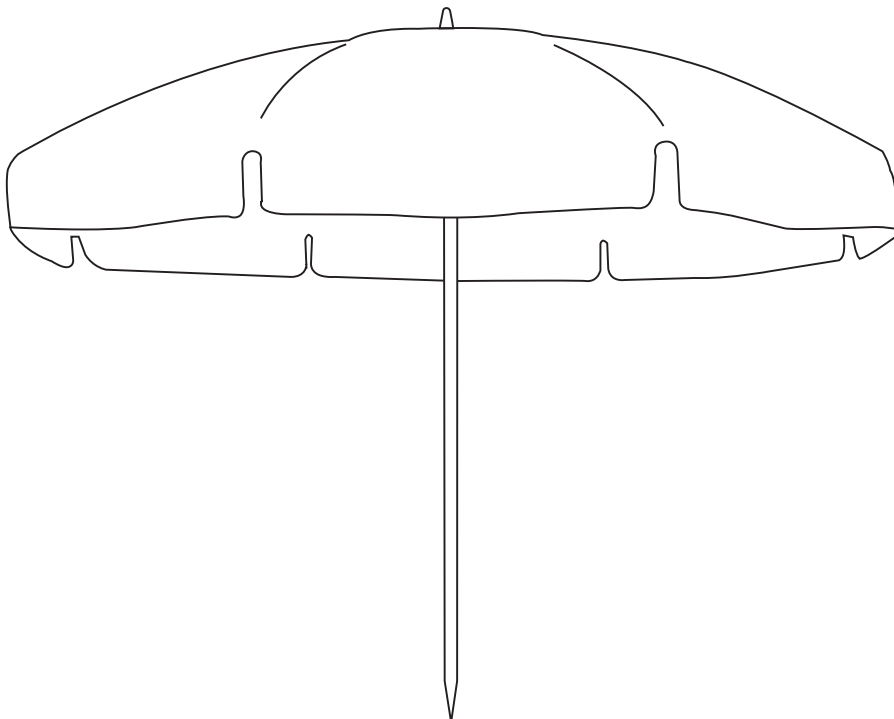

Choose Options

A. OPENING SYSTEM

- Pop-up with button
- Pop-up without button

B. CANOPY FABRIC

- Single
- Alternating

C. MAIN FABRIC

D. TRIM COLOR

E. LOGO PRINTING

- No Logo
- Single color
- Multicolor
- Inkjet Acrylic

Logo Printing Options

- **Single Color** (for basic logos and text)
- **Multicolor** (superb color matching and blending in photographic quality)
- **Inkjet Acrylic** (for projects requiring the entire panel be printed or where you require Pantone Matching System color accuracy for your fabric color).

To customize your umbrella, please select all choice options before adding to cart.

Logo Umbrella Orders

Order your umbrella as normal. Choose all options you would like to include with your umbrella. After your Logo Umbrella order is placed, a customer service representative will contact you within one business day with instructions on where to upload your logo. A proof will be submitted to you for approval with exact logo and/or text placement. When approved, the printing process will begin.

*Sunbrella® Awning Grade fabrics feature a 10-year warranty against staining and fading. Sunbrella® Furniture Grade fabrics feature a 5-year warranty against staining and fading. Outdura® fabric features a 5-year warranty against staining and fading. **This warranty does not cover normal care and cleaning or damage from misuse or abuse.**

Product Specifications

ASSEMBLED DIMENSIONS

92" × 90" × 90"

SHIPPING DIMENSIONS

58" × 6" × 6"

SHIPPING WEIGHT

15 lbs.

ASSEMBLY

This product ships unassembled and will require easy and straight-forward assembly using common household tools. Detailed instructions are included.

Note: See our Umbrella Standards in the back of this section for details on our Delivery for Quotes, Return Policy, Shipping and Warranty information.

Pricing

Please call **1.800.510.8325** for a quote or visit **DesignerCustomSource.com** for instant pricing.

Quick Features

- Sunbrella® Awning and Outdura® Fabrics
- Fiberflex Frames
- 2 Frame Options
- 2 Collections, 3 Styles Each
- Designer Floral Collection
- Designer Sea Island Collection



DESIGNER UMBRELLAS

2012 COLLECTION

Designer Floral Collection Options

CALLA LILY

- Skin: Sunbrella® Natural
- Vent and Band: Sunbrella® Forest Green
- 9' Aluminum Market Umbrella with Pully Lift

SUNFLOWER

- Skin: Sunbrella® Buttercup
- Vent: Sunbrella® Bay Brown
- 9' Aluminum Market Umbrella with Pully Lift

ROSE

- Skin: Sunbrella® Jockey Red
- First Band: Sunbrella® Forest Green
(band on vent and skin)
- 9' Aluminum Market Umbrella with Pully Lift

Designer Sea Island Collection

CORAL REEF

- Skin: Sunbrella® Ginkgo
- Lining: Sunbrella® Tuscan
- Fringe: Sunbrella® Rainbow (4" fringe)
- 9' Wood Market Umbrella with Pully Lift

FRESH FISH

- Skin: Outdura® Go Fish – Skipper (Fabric is two-sided blue ground top, cream ground inside.)
- Tassel: Highland Taylor Atlantic (5" Tassel)
- 9' Wood Market Umbrella with Pully Lift

SWEPT AWAY

- Solid Sunbrella® fabric with colors available / coordinating 4" bullion fringe
- 9' Aluminum Market Umbrella with Pully Lift

Quick Features

- 7.5' Canopy Span
- 8 Panel Octagon
- Sunbrella® or Outdura® Fabric
- Logo Option



7.5' MARKET REPLACEMENT UMBRELLA SKIN

UMBRELLA ACCESSORIES

The **7.5' MARKET REPLACEMENT UMBRELLA CANOPY** is made using your choice of Sunbrella® fabric or Outdura® fabric — covered by a 5-10 year warranty*. This fabric is known for its durability against the elements and its high resistance to staining and fading. While customizing this umbrella, the Alternating Fabric Option will allow you to choose a different fabric for the alternating panels.

Do you need a logo printed on your umbrella? You have the capability of adding a logo to this umbrella on 1 to 8 panels.

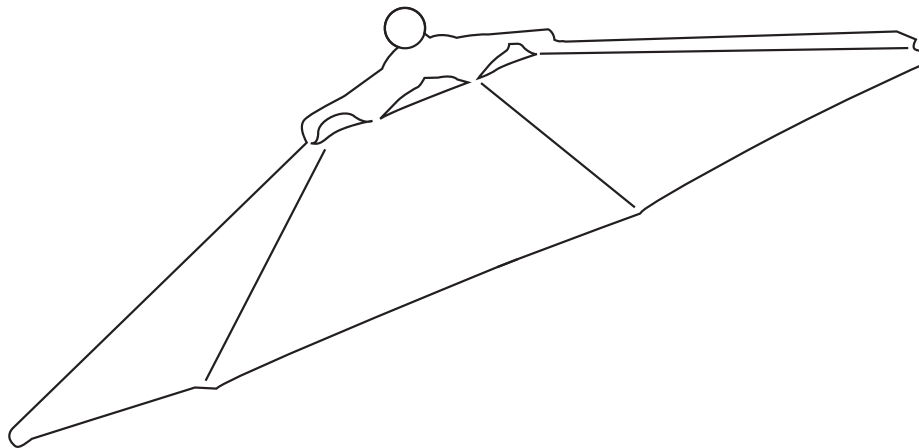

Choose Options

A. CANOPY FABRIC

- Single
- Alternating

B. VENT OPTION

- Single
- Double

C. TOP VENT FABRIC

- Match main fabric
- Match alternate fabric
- Different fabric

D. VALANCE

- No valance
- Add valance

E. LOGO PRINTING

- No logo
- Single color
- Multicolor
- Inkjet acrylic

Logo Printing Options

- **Single Color** (for basic logos and text)
- **Multicolor** (superb color matching and blending in photographic quality)
- **Inkjet Acrylic** (for projects requiring the entire panel be printed or where you require Pantone Matching System color accuracy for your fabric color).

To customize your umbrella, please select all choice options before adding to cart.

Logo Umbrella Orders

Order your umbrella as normal. Choose all options you would like to include with your umbrella. After your Logo Umbrella order is placed, a customer service representative will contact you within one business day with instructions on where to upload your logo. A proof will be submitted to you for approval with exact logo and/or text placement. When approved, the printing process will begin.

*Sunbrella® Awning Grade fabrics feature a 10-year warranty against staining and fading. Sunbrella® Furniture Grade fabrics feature a 5-year warranty against staining and fading. Outdura® fabric features a 5-year warranty against staining and fading. **This warranty does not cover normal care and cleaning or damage from misuse or abuse.**

This replacement cover is meant to fit umbrellas purchased from us. If you have questions regarding umbrella covers and whether they will fit your umbrella frame, please contact us.

Product Specifications

ASSEMBLED DIMENSIONS

2" × 90" × 90"

SHIPPING DIMENSIONS

58" × 6" × 6"

SHIPPING WEIGHT

8 lbs.

ASSEMBLY

This product ships unassembled and will require easy and straight-forward assembly using common household tools. Detailed instructions are included.

Note: See our Umbrella Standards in the back of this section for details on our Delivery for Quotes, Return Policy, Shipping and Warranty information.

Pricing

Please call **1.800.510.8325** for a quote or visit **DesignerCustomSource.com** for instant pricing.

Quick Features

- 9' Canopy Span
- 8 Panel Octagon
- Sunbrella® or Outdura® Fabric
- Logo Option



9' MARKET REPLACEMENT UMBRELLA SKIN

UMBRELLA ACCESSORIES

The **9' MARKET REPLACEMENT UMBRELLA CANOPY** is made using your choice of Sunbrella® fabric or Outdura® fabric — covered by a 5-10 year warranty*. This fabric is known for its durability against the elements and its high resistance to staining and fading. While customizing this umbrella, the Alternating Fabric Option will allow you to choose a different fabric for the alternating panels.

Do you need a logo printed on your umbrella? You have the capability of adding a logo to this umbrella on 1 to 8 panels.

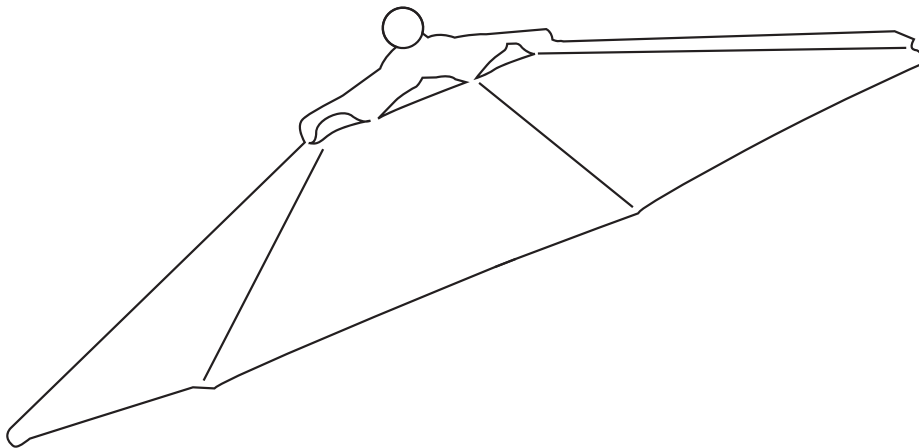

Choose Options

A. CANOPY FABRIC

- Single
- Alternating

B. VENT OPTION

- Single
- Double

C. TOP VENT FABRIC

- Match main fabric
- Match alternate fabric
- Different fabric

D. VALANCE

- No valance
- Add valance

E. LOGO PRINTING

- No logo
- Single color
- Multicolor
- Inkjet acrylic

Logo Printing Options

- **Single Color** (for basic logos and text)
- **Multicolor** (superb color matching and blending in photographic quality)
- **Inkjet Acrylic** (for projects requiring the entire panel be printed or where you require Pantone Matching System color accuracy for your fabric color).

To customize your umbrella, please select all choice options before adding to cart.

Logo Umbrella Orders

Order your umbrella as normal. Choose all options you would like to include with your umbrella. After your Logo Umbrella order is placed, a customer service representative will contact you within one business day with instructions on where to upload your logo. A proof will be submitted to you for approval with exact logo and/or text placement. When approved, the printing process will begin.

*Sunbrella® Awning Grade fabrics feature a 10-year warranty against staining and fading. Sunbrella® Furniture Grade fabrics feature a 5-year warranty against staining and fading. Outdura® fabric features a 5-year warranty against staining and fading. **This warranty does not cover normal care and cleaning or damage from misuse or abuse.**

This replacement cover is meant to fit umbrellas purchased from us. If you have questions regarding umbrella covers and whether they will fit your umbrella frame, please contact us.

Product Specifications

ASSEMBLED DIMENSIONS

2" × 108" × 108"

SHIPPING DIMENSIONS

58" × 6" × 6"

SHIPPING WEIGHT

8 lbs.

ASSEMBLY

This product ships unassembled and will require easy and straight-forward assembly using common household tools. Detailed instructions are included.

Note: See our Umbrella Standards in the back of this section for details on our Delivery for Quotes, Return Policy, Shipping and Warranty information.

Pricing

Please call **1.800.510.8325** for a quote or visit **DesignerCustomSource.com** for instant pricing.



POWDER COATED STEEL SPIKE UMBRELLA STAND



Designer Custom Source presents our exclusive **STEEL SPIKE UMBRELLA STAND** in three sizes. Take your shade with you to the park, the pond or in your backyard. Hammer this Steel Spike Umbrella Stand into the ground, insert your umbrella pole into the umbrella stand neck and tighten the set screw to hold the umbrella securely in place. When you are ready to remove it from the ground, simply remove your umbrella and tap the side of the spike a couple of times to loosen the spike and wiggle the portable umbrella stand out of the ground.

Choose Options

SMALL (For umbrella poles up to 1.5" diameter.)

- Dimensions: 4" x 4" x 18" (2 lbs.)
- Amount of Spike Buried: 12"

MEDIUM (For umbrella poles up to 2" diameter.)

- Dimensions: 4" x 4" x 24" (3.5 lbs.)
- Amount of Spike Buried: 15"

LARGE (For umbrella poles up to 2.5" diameter.)

- Dimensions: 6" x 6" x 32" (8 lbs.)
- Amount of Spike Buried: 21"

Product Specifications

SHIPPING DIMENSIONS

34" x 8" x 8"

SHIPPING WEIGHT

6 lbs.

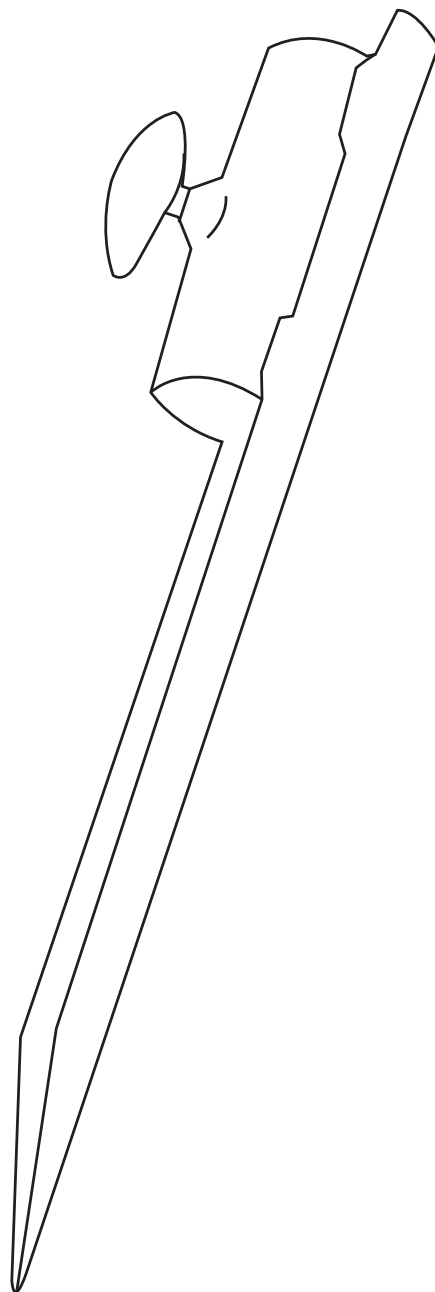

CAST IRON SQUARE UMBRELLA STAND



This **CAST IRON SQUARE UMBRELLA STAND** will add the finishing touch to any setting! Adding beauty and style with functionality, this umbrella stand is constructed of durable cast iron and features a hardened powder coat finish for years of beauty. The Square Umbrella Stand can fit up to a 1 7/8" umbrella pole.

Product Specifications

ASSEMBLED DIMENSIONS

24" × 24" × 12"

SHIPPING DIMENSIONS

25" × 25" × 6 1/2"

SHIPPING WEIGHT

43 lbs.

ASSEMBLY

This product ships unassembled and will require easy and straight-forward assembly using common household tools. Detailed instructions are included.

Note: See our Umbrella Standards in the back of this section for details on our Delivery for Quotes, Return Policy, Shipping and Warranty information.

Pricing

Please call **1.800.510.8325** for a quote or visit **DesignerCustomSource.com** for instant pricing.

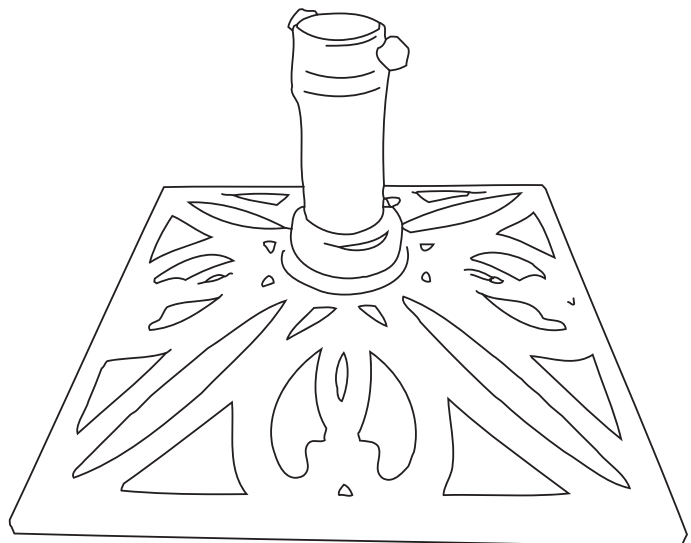



FLAT STEEL UMBRELLA BASE

Our low-profile **FLAT STEEL UMBRELLA STAND** will provide a sturdy base for a 7 ½', 8'-11' umbrella. These industry-standard umbrella stands have a low-profile steel square base plate and a heavy-duty base sleeve that is 15 ¾" high. The standard sleeve accommodates poles up to 2" in diameter. These durable powder-coated umbrella stands from Designer Custom Source allow you to easily place a table and chairs around and over them. These steel umbrella stands are available with wheels and are most popular in many commercial restaurant and high-traffic applications. This stand is only available in black.

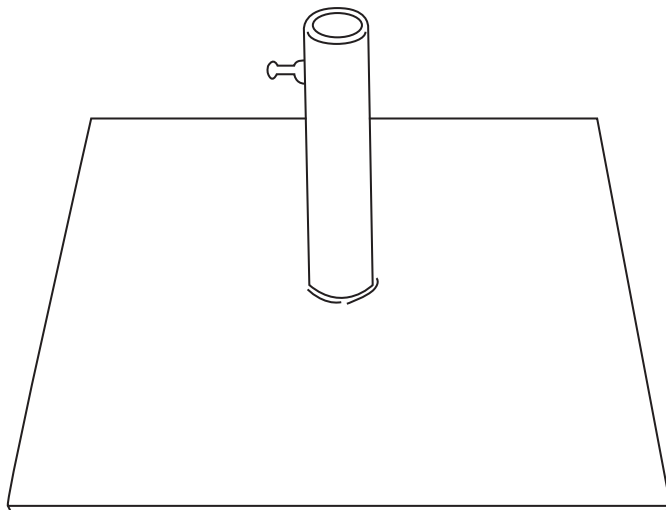

Choose Options

BASE SIZE

- 20" – 50 lbs.
- 26 ½" – 78 lbs.
 - Add wheels
 - No wheels
- 26 ½" – 128 lbs.

Product Specifications

ASSEMBLED DIMENSIONS

26 ½" × 26 ½" × 15 ¾"

SHIPPING DIMENSIONS

34" × 30" × 4"

SHIPPING WEIGHT

80 lbs.

ASSEMBLY

This product ships as a complete unit and does not require any assembly upon receipt.

Note: See our Umbrella Standards in the back of this section for details on our Delivery for Quotes, Return Policy, Shipping and Warranty information.

Pricing

Please call **1.800.510.8325** for a quote or visit **DesignerCustomSource.com** for instant pricing.



UMBRELLA STANDARDS

Product and Delivery

There is a minimum 2-3 week production time from receipt of payment for all orders, without printing; minimum 3-4 weeks from receipt of payment and approved graphics for all orders with printing. Rush Charge of 30% applies to expedited orders requiring faster delivery. Freight quote will be determined based on quantity. Freight quote, if provided, is intended solely as an estimate of freight cost. However, as we do not control freight rates and charges from our chosen carriers, freight costs will be charged to you as incurred, regardless of quote provided.

Shipping

Our products ship via FedEx or UPS (depending on your zip code). Once shipped, you will receive a tracking number via the email address you provide. Ground shipments usually arrive within 2-5 business days. Please inspect the package when it arrives to review if damage occurred during shipping. If a box is crushed, wet or severely damaged, reject the shipment and do not sign for it. The item will be returned to us, which allows us to file a claim. We will then be able to ship your replacement item within 24 hours. If shipment is found to be damaged after delivery, contact customer service immediately so a claim can be filed. Please retain all damaged items and shipping materials, as the carrier may need to perform an inspection.

Warranty

Designer Custom Source offers a 1-year basic warranty on our products to the original purchaser from the date of purchase against defects in material and workmanship. During this period, Designer Custom Source will repair or replace, at our discretion, the defective component.

This warranty does not apply to items improperly installed, handled, abused, or damaged by user error, nor to any unit which has been repaired or altered by unauthorized repair companies. Designer Custom Source also does not cover product failure caused by unreasonable use and/or care, or acts of nature (i.e. wind/storm damage). Under no circumstances will the buyer be entitled to consequential or incidental damages. This limited 1-year basic warranty gives you specific legal rights; you may have other rights which vary from state to state where you live. Batteries and plastic housings are not covered by warranty.

Return Policy

To return a product based upon the replacement/return guarantee of Designer Custom Source, you must call or e-mail our Returns Department and obtain a Return Merchandise Authorization (“RMA”) number within the guarantee return period for the product (described above). Designer Custom Source will not accept returns without prior authorization and an RMA number. Once issued, RMA numbers are valid for 15 days in which must be returned to Designer Custom Source. RMA numbers will not be extended or reissued. Customer should prominently display the RMA number(s) on the shipping label of boxes containing the returned product.

Customer is solely responsible for shipping any returned product to Designer Custom Source. Customer agrees to use only reputable carriers capable of providing proof of delivery and insurance for the entire value of the shipment. Customer agrees to bear all shipping charges and all risk of loss for the return product during shipment. Customer agrees that all returned products will be 100% complete, in resaleable condition, and will include the original packaging material, manuals, blank warranty cards, and other accessories provided by the manufacturer. If any component of the returned product is missing, Designer Custom Source Return Procedure will be breached and Designer Custom Source will reject the entire return or may choose to impose additional charges against the customer for replacement of the missing component.

Designer Custom Source will not refund to Customer the original shipping charges. In addition, Designer Custom Source charges a 25% restocking fee on all non-defective returns for refund.

Products being returned for a refund must be received by Designer Custom Source prior to 30 days from the original invoice date. Returns received after the 30-day return period will no longer be eligible for refund.

Shipping charges are nonrefundable.

ITEMS WITH FREE SHIPPING

Returns on items that included ‘Free Shipping’ will be credited for the item ONLY minus the original shipping charges we incurred to ship the item(s) out to you and restocking fees will still apply. ‘Free Shipping’ will no longer apply once the item is returned. You will be responsible for the return shipping charges, as well as the shipping charges to send your replacement item.

NO RETURNS ON CUSTOM ORDERS.



CUSTOMER'S OWN MATERIAL (COM)



There is nothing more satisfying than a custom product. Enhance your satisfaction and service your client further by using your specified fabrics, buttons and trims.

SEND YOUR COM TO:

Designer Custom Source
Attn: COM Orders
3180 Wetumpka Hwy.
Montgomery, AL 36110

Important: Please ATTACH a copy of your invoice to the fabric when you send it. If you cannot send a copy of your invoice, please ATTACH the following to the fabric: your name, invoice number, ship to address, phone number, and e-mail address.

Designer Custom Source lets your imagination create designs with your favorite fabrics, trims and buttons.

CUSTOMER'S OWN MATERIAL PROCEDURES



Step 1

Select COMFAB at the Fabric Selection step.

Step 2

Determine the quantity of fabric you will need. Consider the repeat, cording, and stripe patterns when determining the yardage requirements. When you place an order, a fabric requirement estimate is shown on your invoice. Please only use this estimate as a guide for determining how much fabric to send. For striped COM fabric, please add an additional 15% fabric and indicate which direction the stripe should run (vertically or horizontally). If reversible, please specify which side to use. If you are using a different COM fabric for the cording (welting), clearly indicate which fabric is to be used for the cording. Please send only cut fabric.

Step 3

SEND YOUR FABRIC TO:

Designer Custom Source
Attn: COM Orders
3180 Wetumpka Hwy.
Montgomery, AL 36110

Important: Please ATTACH a copy of your invoice to the fabric when you send it. If you cannot send a copy of your invoice, please ATTACH the following to the fabric: your name, invoice number, ship to address, phone number and e-mail address.



CUSTOMER'S OWN MATERIAL

FAQ



Where do I find out how much fabric to send?

After you place an order, a fabric requirement estimate will be shown on your invoice. Please note, this is just an estimate; if your fabric has a large repeat, a stripe pattern, or a cording requirement, please plan on sending more fabric than the estimate — we recommend an additional 15%. If the COM quantity received is inadequate to complete the order, we will make the cushions with the fabric we have and contact you for more fabric to complete the order. Leftover fabric will be discarded.

How long will my order take?

Once we receive your fabric, your custom cushion order will take up to 20 business days for completion. Our goal is 10–15 business days or less. Once shipped, depending where you are, Ground Shipping can take up to 5 business days for delivery. Since we are shipping from the eastern U.S., a California cushion order will spend 5 business days in transit.

How should I ship my fabric?

Customers should send COM via a shipping service that provides a tracking number and proof of delivery. The customer will be responsible for fabric until it is in our possession as evidenced by a signed tracking document.

COM fabrics must be readily available in the marketplace at competitive prices in the event Designer Custom Source needs to replace the fabric due to loss or damage. We reserve the right to decline fabrics that we deem to be difficult or problematic. We do not sew texelene or sheers, for example. Designer Custom Source liability for lost, misplaced or damaged fabrics will not exceed \$50 per yard. Proof of purchase with pricing may be required.



FABRIC LIBRARY



Name	SID	Retail	Repeat Size (Inches)	Roll Width (Inches)	Materials
Sunbrella Heritage Ashe	18001-0000	\$33.28	0.00 x 0.00	54	100% Acrylic - Solution Dyed
Sunbrella Heritage Granite	18004-0000	\$33.28	0.00 x 0.00	54	100% Acrylic - Solution Dyed
Sunbrella Kamal Chestnut	30503-0000	\$21.67	0.00 x 0.00	54	100% Acrylic - Solution Dyed
Sunbrella Sailcloth Shell	32000-0000	\$34.86	0.00 x 0.00	54	100% Acrylic - Solution Dyed
Sunbrella Sailcloth Sand	32000-0002	\$24.40	0.00 x 0.00	54	100% Acrylic - Solution Dyed
Sunbrella Sailcloth Shore	32000-0003	\$34.86	0.00 x 0.00	54	100% Acrylic - Solution Dyed
Sunbrella Sailcloth Suntan	32000-0007	\$34.86	0.00 x 0.00	54	100% Acrylic - Solution Dyed
Sunbrella Sailcloth Sahara	32000-0016	\$24.40	0.00 x 0.00	54	100% Acrylic - Solution Dyed
Sunbrella Sailcloth Sienna	32000-0017	\$24.40	0.00 x 0.00	54	100% Acrylic - Solution Dyed
Sunbrella Sailcloth Salt	32000-0018	\$24.40	0.00 x 0.00	54	100% Acrylic - Solution Dyed
Sunbrella Sailcloth Spice	32000-0019	\$34.86	0.00 x 0.00	54	100% Acrylic - Solution Dyed
Sunbrella Sailcloth Seagull	32000-0023	\$34.86	0.00 x 0.00	54	100% Acrylic - Solution Dyed
Sunbrella Sailor Salt	32004-0000	\$36.97	3.57 x 0.00	54	100% Acrylic - Solution Dyed
Sunbrella Sailor Sand	32006-0000	\$36.95	3.57 x 0.00	54	100% Acrylic - Solution Dyed
Sunbrella Fife Plum	40012-0075	\$24.73	0.00 x 0.00	54	100% Acrylic - Solution Dyed
Sunbrella Botticelli Harvest	40203-0001	\$35.98	14.00 x 0.00	54	100% Acrylic - Solution Dyed
Sunbrella Marcello Seaglass	40236-0005	\$20.07	14.22 x 0.00	54	100% Acrylic - Solution Dyed
Sunbrella Marcello Sunset	40236-0009	\$20.07	14.22 x 14.22	54	100% Acrylic - Solution Dyed
Sunbrella Flow Spring	40301-0004	\$27.72	12.80 x 12.80	54	100% Acrylic - Solution Dyed
Sunbrella Canyon Cocoa	42006-0006	\$37.93	0.00 x 0.00	54	100% Acrylic - Solution Dyed
Sunbrella Canyon Walnut	42006-0007	\$20.86	0.00 x 0.00	54	100% Acrylic - Solution Dyed
Sunbrella Mainstreet Wren	42048-0005	\$40.38	0.33 x 0.25	54	100% Acrylic - Solution Dyed
Sunbrella Mainstreet Latte	42048-0009	\$40.39	0.33 x 0.25	54	100% Acrylic - Solution Dyed
Sunbrella Sponge Barley	44154-0004	\$27.43	0.00 x 0.00	54	100% Acrylic - Solution Dyed



Name	SID	Retail	Repeat Size (Inches)	Roll Width (Inches)	Materials
Sunbrella Worcester Fandango	44156-0009	\$29.01	2.00 x 1.90	54	100% Acrylic - Solution Dyed
Sunbrella Tab Tangerine	44163-0003	\$29.01	0.92 x 0.71	54	100% Acrylic - Solution Dyed
Sunbrella Tab Twilight	44163-0013	\$29.01	0.92 x 0.71	54	100% Acrylic - Solution Dyed
Sunbrella Cabaret Bluehaze	45099-0003	\$22.26	28.20 x 28.00	54	100% Acrylic - Solution Dyed
Sunbrella Villette Rococco	45155-0004	\$33.59	27.00 x 27.00	54	100% Acrylic - Solution Dyed
Sunbrella Mojito Coffee Bean	45184-0004	\$25.46	6.80 x 7.18	54	100% Acrylic - Solution Dyed
Sunbrella Merritt Mint	45225-0004	\$19.23	24.00 x 29.00	54	100% Acrylic - Solution Dyed
Sunbrella Newbury Sunset	45399-0000	\$27.23	28.00 x 13.50	54	100% Acrylic - Solution Dyed
Sunbrella Blox Slate	45542-0000	\$38.45	8.80 x 9.90	54	100% Acrylic - Solution Dyed
Sunbrella Splendor Fiesta	45584-0002	\$49.47	13.88 x 28.00	54	100% Acrylic - Solution Dyed
Sunbrella Luxe Indigo	45690-0000	\$39.63	6.85 x 7.00	54	100% Acrylic - Solution Dyed
Sunbrella Mankala Dusk	45701-0007	\$39.63	13.03 x 14.00	54	100% Acrylic - Solution Dyed
Sunbrella El Greco Calypso	45706-0000	\$39.63	8.46 x 14.00	54	100% Acrylic - Solution Dyed
Sunbrella El Greco Avocado	45706-0001	\$39.63	8.46 x 14.00	54	100% Acrylic - Solution Dyed
Sunbrella Aura Honey	45707-0002	\$47.58	26.93 x 14.00	54	100% Acrylic - Solution Dyed
Sunbrella Tango Mink	45713-0003	\$44.91	13.71 x 14.00	54	100% Acrylic - Solution Dyed
Sunbrella Elegance Marble	45746-0001	\$42.08	13.48 x 14.00	54	100% Acrylic - Solution Dyed
Sunbrella Violetta Baltic	45760-0002	\$44.55	26.67 x 28.00	54	100% Acrylic - Solution Dyed
Sunbrella Spectrum Eggshell	48018-0000	\$13.65	0.00 x 0.00	54	100% Acrylic - Solution Dyed
Sunbrella Spectrum Sand	48019-0000	\$13.65	0.00 x 0.00	54	100% Acrylic - Solution Dyed
Sunbrella Spectrum Mist	48020-0000	\$13.65	0.00 x 0.00	54	100% Acrylic - Solution Dyed
Sunbrella Spectrum Sailor	48021-0000	\$13.65	0.00 x 0.00	54	100% Acrylic - Solution Dyed
Sunbrella Spectrum Cilantro	48022-0000	\$15.40	0.00 x 0.00	54	100% Acrylic - Solution Dyed
Sunbrella Spectrum Kiwi	48023-0000	\$16.84	0.00 x 0.00	54	100% Acrylic - Solution Dyed



Name	SID	Retail	Repeat Size (Inches)	Roll Width (Inches)	Materials
Sunbrella Spectrum Daffodil	48024-0000	\$16.84	0.00 x 0.00	54	100% Acrylic - Solution Dyed
Sunbrella Spectrum Dijon	48025-0000	\$13.65	0.00 x 0.00	54	100% Acrylic - Solution Dyed
Sunbrella Spectrum Cayenne	48026-0000	\$15.40	0.00 x 0.00	54	100% Acrylic - Solution Dyed
Sunbrella Spectrum Grenadine	48027-0000	\$19.24	0.00 x 0.00	54	100% Acrylic - Solution Dyed
Sunbrella Spectrum Sierra	48028-0000	\$13.65	0.00 x 0.00	54	100% Acrylic - Solution Dyed
Sunbrella Spectrum Coffee	48029-0000	\$15.40	0.00 x 0.00	54	100% Acrylic - Solution Dyed
Sunbrella Spectrum Graphite	48030-0000	\$13.65	0.00 x 0.00	54	100% Acrylic - Solution Dyed
Sunbrella Spectrum Mushroom	48031-0000	\$16.84	0.00 x 0.00	54	100% Acrylic - Solution Dyed
Sunbrella Spectrum Dove	48032-0000	\$13.65	0.00 x 0.00	54	100% Acrylic - Solution Dyed
Sunbrella Parkway Carbon	48038-0000	\$18.64	2.86 x 0.00	54	100% Acrylic - Solution Dyed
Sunbrella Shadow Snow	51000-0000	\$15.19	0.00 x 0.00	54	100% Acrylic - Solution Dyed
Sunbrella Shadow Sand	51000-0001	\$15.19	0.00 x 0.00	54	100% Acrylic - Solution Dyed
Sunbrella Shadow Antique Beige	51000-0004	\$15.19	0.00 x 0.00	54	100% Acrylic - Solution Dyed
Sunbrella Shadow Wren	51000-0005	\$15.19	0.00 x 0.00	54	100% Acrylic - Solution Dyed
Sunbrella Shadow Charcoal	51000-0013	\$15.19	0.00 x 0.00	54	100% Acrylic - Solution Dyed
Sunbrella Shadow Wheat	51000-0015	\$15.19	0.00 x 0.00	54	100% Acrylic - Solution Dyed
Sunbrella Pacific Blue	5401-0000	\$15.10	0.00 x 0.00	54	100% Acrylic - Solution Dyed
Sunbrella Rust	54010-0000	\$21.64	0.00 x 0.00	54	100% Acrylic - Solution Dyed
Sunbrella Ginkgo	54011-0000	\$16.45	0.00 x 0.00	54	100% Acrylic - Solution Dyed
Sunbrella Jockey Red	5403-0000	\$17.09	0.00 x 0.00	54	100% Acrylic - Solution Dyed
Sunbrella Natural	5404-0000	\$15.10	0.00 x 0.00	54	100% Acrylic - Solution Dyed
Sunbrella Parrot	5405-0000	\$17.09	0.00 x 0.00	54	100% Acrylic - Solution Dyed
Sunbrella Tangerine	5406-0000	\$17.09	0.00 x 0.00	54	100% Acrylic - Solution Dyed
Sunbrella Henna	5407-0000	\$17.09	0.00 x 0.00	54	100% Acrylic - Solution Dyed



Name	SID	Retail	Repeat Size (Inches)	Roll Width (Inches)	Materials
Sunbrella Black	5408-0000	\$15.10	0.00 x 0.00	54	100% Acrylic - Solution Dyed
Sunbrella Brick	5409-0000	\$17.09	0.00 x 0.00	54	100% Acrylic - Solution Dyed
Sunbrella Air Blue	5410-0000	\$15.10	0.00 x 0.00	54	100% Acrylic - Solution Dyed
Sunbrella Spa	5413-0000	\$15.10	0.00 x 0.00	54	100% Acrylic - Solution Dyed
Sunbrella Wheat	5414-0000	\$15.10	0.00 x 0.00	54	100% Acrylic - Solution Dyed
Sunbrella Melon	5415-0000	\$15.10	0.00 x 0.00	54	100% Acrylic - Solution Dyed
Sunbrella Aruba	5416-0000	\$15.10	0.00 x 0.00	54	100% Acrylic - Solution Dyed
Sunbrella Tuscan	5417-0000	\$17.09	0.00 x 0.00	54	100% Acrylic - Solution Dyed
Sunbrella Celadon	5419-0000	\$15.10	0.00 x 0.00	54	100% Acrylic - Solution Dyed
Sunbrella Mineral Blue	5420-0000	\$15.10	0.00 x 0.00	54	100% Acrylic - Solution Dyed
Sunbrella Palm	5421-0000	\$17.09	0.00 x 0.00	54	100% Acrylic - Solution Dyed
Sunbrella Antique Beige	5422-0000	\$15.10	0.00 x 0.00	54	100% Acrylic - Solution Dyed
Sunbrella Sky Blue	5424-0000	\$15.10	0.00 x 0.00	54	100% Acrylic - Solution Dyed
Sunbrella Cocoa	5425-0000	\$15.10	0.00 x 0.00	54	100% Acrylic - Solution Dyed
Sunbrella Capri	5426-0000	\$15.10	0.00 x 0.00	54	100% Acrylic - Solution Dyed
Sunbrella Coral	5427-0000	\$15.10	0.00 x 0.00	54	100% Acrylic - Solution Dyed
Sunbrella Glacier	5428-0000	\$15.10	0.00 x 0.00	54	100% Acrylic - Solution Dyed
Sunbrella Macaw	5429-0000	\$17.09	0.00 x 0.00	54	100% Acrylic - Solution Dyed
Sunbrella Bay Brown	5432-0000	\$17.09	0.00 x 0.00	54	100% Acrylic - Solution Dyed
Sunbrella Cornsilk	5435-0000	\$15.10	0.00 x 0.00	54	100% Acrylic - Solution Dyed
Sunbrella Burgundy	5436-0000	\$17.09	0.00 x 0.00	54	100% Acrylic - Solution Dyed
Sunbrella Buttercup	5438-0000	\$15.10	0.00 x 0.00	54	100% Acrylic - Solution Dyed
Sunbrella Navy	5439-0000	\$15.10	0.00 x 0.00	54	100% Acrylic - Solution Dyed
Sunbrella Terracotta	5440-0000	\$17.09	0.00 x 0.00	54	100% Acrylic - Solution Dyed



Name	SID	Retail	Repeat Size (Inches)	Roll Width (Inches)	Materials
Sunbrella Basil	5443	\$15.10	0.00 x 0.00	54	100% Acrylic - Solution Dyed
Sunbrella Nutmeg	5445	\$17.09	0.00 x 0.00	54	100% Acrylic - Solution Dyed
Sunbrella Forest Green	5446-0000	\$15.10	0.00 x 0.00	54	100% Acrylic - Solution Dyed
Sunbrella Turf	5447	\$15.10	0.00 x 0.00	54	100% Acrylic - Solution Dyed
Sunbrella Cork	5448	\$15.10	0.00 x 0.00	54	100% Acrylic - Solution Dyed
Sunbrella Paprika	5451	\$16.45	0.00 x 0.00	54	100% Acrylic - Solution Dyed
Sunbrella Sapphire Blue	5452-0000	\$15.10	0.00 x 0.00	54	100% Acrylic - Solution Dyed
Sunbrella Canvas	5453-0000	\$15.10	0.00 x 0.00	54	100% Acrylic - Solution Dyed
Sunbrella Teal	5456-0000	\$15.10	0.00 x 0.00	54	100% Acrylic - Solution Dyed
Sunbrella Sunflower Yellow	5457-0000	\$15.10	0.00 x 0.00	54	100% Acrylic - Solution Dyed
Sunbrella Taupe	5461-0000	\$15.10	0.00 x 0.00	54	100% Acrylic - Solution Dyed
Sunbrella Hot Pink	5462-0000	\$17.09	0.00 x 0.00	54	100% Acrylic - Solution Dyed
Sunbrella Camel	5468-0000	\$15.10	0.00 x 0.00	54	100% Acrylic - Solution Dyed
Sunbrella Walnut	5470-0000	\$15.10	0.00 x 0.00	54	100% Acrylic - Solution Dyed
Sunbrella Raven Black	5471-0000	\$17.03	0.00 x 0.00	54	100% Acrylic - Solution Dyed
Sunbrella Bird's Eye	5472-0000	\$15.10	0.00 x 0.00	54	100% Acrylic - Solution Dyed
Sunbrella Stone Green	5473-0000	\$17.03	0.00 x 0.00	54	100% Acrylic - Solution Dyed
Sunbrella Heather Beige	5476-0000	\$18.87	0.00 x 0.00	54	100% Acrylic - Solution Dyed
Sunbrella Logo Red	5477-0000	\$17.09	0.00 x 0.00	54	100% Acrylic - Solution Dyed
Sunbrella Brass	5484-0000	\$15.10	0.00 x 0.00	54	100% Acrylic - Solution Dyed
Sunbrella Fern	5487-0000	\$15.10	0.00 x 0.00	54	100% Acrylic - Solution Dyed
Sunbrella Teak	5488-0000	\$15.10	0.00 x 0.00	54	100% Acrylic - Solution Dyed
Sunbrella Coal	5489-0000	\$15.10	0.00 x 0.00	54	100% Acrylic - Solution Dyed
Sunbrella Vellum	5498-0000	\$15.10	0.00 x 0.00	54	100% Acrylic - Solution Dyed



Name	SID	Retail	Repeat Size (Inches)	Roll Width (Inches)	Materials
Sunbrella True Blue	5499-0000	\$15.10	0.00 x 0.00	54	100% Acrylic - Solution Dyed
Sunbrella Dolce Mango	56000-0000	\$15.10	0.00 x 8.90	54	100% Acrylic - Solution Dyed
Sunbrella Dolce Oasis	56001-0000	\$15.10	0.00 x 8.90	54	100% Acrylic - Solution Dyed
Sunbrella Weston Ginger	56005-0000	\$15.10	0.00 x 6.26	54	100% Acrylic - Solution Dyed
Sunbrella Bravada Salsa	5601-0000	\$17.09	0.00 x 6.81	54	100% Acrylic - Solution Dyed
Sunbrella Derby Chili	56018-0000	\$14.24	0.00 x 2.72	54	100% Acrylic - Solution Dyed
Sunbrella Bravada Limelite	5602-0000	\$17.09	0.00 x 6.81	54	100% Acrylic - Solution Dyed
Sunbrella Harwood Onyx	56023	\$14.64	1.50 x 0.00	54	100% Acrylic - Solution Dyed
Sunbrella Harwood Cocoa	56024	\$15.10	1.50 x 0.00	54	100% Acrylic - Solution Dyed
Sunbrella Harwood Peridot	56025	\$14.64	1.50 x 0.00	54	100% Acrylic - Solution Dyed
Sunbrella Harwood Crimson	5603-0000	\$17.02	0.00 x 1.36	54	100% Acrylic - Solution Dyed
Sunbrella Manchester Sienna	56031-0000	\$15.10	0.00 x 5.44	54	100% Acrylic - Solution Dyed
Sunbrella Castanet Beach	5604-0000	\$15.10	0.00 x 8.87	54	100% Acrylic - Solution Dyed
Sunbrella Scavo Willow	56040	\$15.74	0.00 x 13.75	54	100% Acrylic - Solution Dyed
Sunbrella Foster Surfside	56049-0000	\$15.10	0.00 x 6.75	54	100% Acrylic - Solution Dyed
Sunbrella Foster Classic	56050-0000	\$15.10	0.00 x 6.75	54	100% Acrylic - Solution Dyed
Sunbrella Foster Metallic	56051-0000	\$15.10	0.00 x 6.75	54	100% Acrylic - Solution Dyed
Sunbrella Gavin Mist	56052-0000	\$15.10	0.00 x 6.80	54	100% Acrylic - Solution Dyed
Sunbrella Bristol Dusk	56058-0000	\$18.87	4.50 x 0.00	54	100% Acrylic - Solution Dyed
Sunbrella Davidson Redwood	5606-0000	\$15.10	0.00 x 4.50	54	100% Acrylic - Solution Dyed
Sunbrella Zenith Chestnut	56061-0000	\$21.35	0.00 x 6.80	54	100% Acrylic - Solution Dyed
Sunbrella Steeplechase Malibu	56064-0000	\$15.10	9.00 x 0.00	54	100% Acrylic - Solution Dyed
Sunbrella Cassidy Meadow	56067-0000	\$24.38	0.00 x 6.00	54	100% Acrylic - Solution Dyed
Sunbrella Cassidy Pebble	56068-0000	\$24.38	0.00 x 6.00	54	100% Acrylic - Solution Dyed



Name	SID	Retail	Repeat Size (Inches)	Roll Width (Inches)	Materials
Sunbrella Timeline Nautical	56069-0000	\$22.53	0.00 x 5.43	54	100% Acrylic - Solution Dyed
Sunbrella Davidson Walnut	5607-0000	\$15.10	4.50 x 0.00	54	100% Acrylic - Solution Dyed
Sunbrella Timeline Sprout	56070-0000	\$25.17	5.43 x 0.00	54	100% Acrylic - Solution Dyed
Sunbrella Passage Poppy	56071-0000	\$20.31	8.87 x 0.00	54	100% Acrylic - Solution Dyed
Sunbrella Passage Seagrass	56072-0000	\$20.31	8.87 x 0.00	54	100% Acrylic - Solution Dyed
Sunbrella Timeline Caravan	56073-0000	\$22.53	5.43 x 0.00	54	100% Acrylic - Solution Dyed
Sunbrella Seville Seaside	5608-0000	\$15.10	0.00 x 8.87	54	100% Acrylic - Solution Dyed
Sunbrella Elliott Wren	5610-0000	\$15.10	0.00 x 6.81	54	100% Acrylic - Solution Dyed
Sunbrella Brannon Redwood	5612-0000	\$15.10	0.00 x 8.87	54	100% Acrylic - Solution Dyed
Sunbrella Brannon Whisper	5621-0000	\$15.10	0.00 x 8.88	54	100% Acrylic - Solution Dyed
Sunbrella Maxim Cocoa	5626-0000	\$15.10	0.00 x 4.18	54	100% Acrylic - Solution Dyed
Sunbrella Mason Forest Green	5630-0000	\$15.10	0.00 x 2.00	54	100% Acrylic - Solution Dyed
Sunbrella Maxim Heather Beige	5674-0000	\$15.10	0.00 x 4.18	54	100% Acrylic - Solution Dyed
Sunbrella Regency Sand	5695-0000	\$17.03	9.00 x 0.00	54	100% Acrylic - Solution Dyed
Sunbrella Dorsett Autumn	5698-0000	\$15.10	0.00 x 3.44	54	100% Acrylic - Solution Dyed
Sunbrella Coventry Gourd	70007-0001	\$37.95	0.00 x 0.00	54	100% Acrylic - Solution Dyed
Sunbrella Bessemer 1000BA	7253-0000	\$19.73	13.20 x 13.50	54	100% Acrylic - Solution Dyed
Sunbrella Pango Wren	73012-0003	\$34.98	6.75 x 14.13	54	100% Acrylic - Solution Dyed
Sunbrella Natural Rib	7704-0000	\$17.71	0.00 x 0.00	54	100% Acrylic - Solution Dyed
Sunbrella Antique Beige Rib	7722-0000	\$22.55	0.00 x 0.00	54	100% Acrylic - Solution Dyed
Sunbrella Renata Hemp	8005-0000	\$17.71	2.19 x 1.75	54	100% Acrylic - Solution Dyed
Sunbrella Dupione Pearl	8010-0000	\$17.71	0.00 x 0.00	54	100% Acrylic - Solution Dyed
Sunbrella Dupione Sand	8011-0000	\$17.71	0.00 x 0.00	54	100% Acrylic - Solution Dyed
Sunbrella Dupione Cornsilk	8012-0000	\$17.71	0.00 x 0.00	54	100% Acrylic - Solution Dyed



Name	SID	Retail	Repeat Size (Inches)	Roll Width (Inches)	Materials
Sunbrella Dupione Bamboo	8013-0000	\$17.71	0.00 x 0.00	54	100% Acrylic - Solution Dyed
Sunbrella Dupione Maize	8014-0000	\$21.44	0.00 x 0.00	54	100% Acrylic - Solution Dyed
Sunbrella Dupione Laurel	8015-0000	\$17.71	0.00 x 0.00	54	100% Acrylic - Solution Dyed
Sunbrella Dupione Galaxy	8016-0000	\$17.71	0.00 x 0.00	54	100% Acrylic - Solution Dyed
Sunbrella Dupione Walnut	8017-0000	\$17.71	0.00 x 0.00	54	100% Acrylic - Solution Dyed
Sunbrella Dupione Deep Sea	8019-0000	\$17.71	0.00 x 0.00	54	100% Acrylic - Solution Dyed
Sunbrella Dimone Flame	8021-0000	\$17.71	0.00 x 5.50	54	100% Acrylic - Solution Dyed
Sunbrella Dash Crimson	8028-0000	\$25.17	1.20 x 1.40	54	100% Acrylic - Solution Dyed
Sunbrella Dash Redwood	8029-0000	\$19.61	1.20 x 1.40	54	100% Acrylic - Solution Dyed
Sunbrella Dimone Sequoia	8031-0054	\$17.04	0.00 x 5.50	54	100% Acrylic - Solution Dyed
Sunbrella Dash Walnut	8032-0000	\$17.71	1.20 x 1.40	54	100% Acrylic - Solution Dyed
Sunbrella Wyndham Mocha	8036-0000	\$22.91	0.00 x 0.70	54	100% Acrylic - Solution Dyed
Sunbrella Wyndham Dune	8037-0000	\$21.35	0.00 x 0.70	54	100% Acrylic - Solution Dyed
Sunbrella Wyndham Wheat	8038-0000	\$21.35	0.00 x 0.70	54	100% Acrylic - Solution Dyed
Sunbrella Carnegie Willow	8041-0000	\$24.38	5.45 x 0.00	54	100% Acrylic - Solution Dyed
Sunbrella Carnegie Hearth	8042-0000	\$24.38	5.45 x 0.00	54	100% Acrylic - Solution Dyed
Sunbrella Darby Flame	8044-0000	\$27.11	5.44 x 0.00	54	100% Acrylic - Solution Dyed
Sunbrella Dupione Paradise	8050-0000	\$25.17	0.00 x 0.00	54	100% Acrylic - Solution Dyed
Sunbrella Dupione Crimson	8051-0000	\$25.17	0.00 x 0.00	54	100% Acrylic - Solution Dyed
Sunbrella Dupione Palm	8052-0000	\$19.61	0.00 x 0.00	54	100% Acrylic - Solution Dyed
Sunbrella Dupione Papaya	8053-0000	\$19.61	0.00 x 0.00	54	100% Acrylic - Solution Dyed
Sunbrella Dupione Henna	8056-0000	\$25.17	0.00 x 0.00	54	100% Acrylic - Solution Dyed
Sunbrella Dupione Oak	8057	\$18.75	0.00 x 0.00	54	100% Acrylic - Solution Dyed
Sunbrella Dupione Seafoam	8058	\$17.71	0.00 x 0.00	54	100% Acrylic - Solution Dyed



Name	SID	Retail	Repeat Size (Inches)	Roll Width (Inches)	Materials
Sunbrella Dupione Caramel	8059	\$18.75	0.00 x 0.00	54	100% Acrylic - Solution Dyed
Sunbrella Dupione Stone	8060	\$21.00	0.00 x 0.00	54	100% Acrylic - Solution Dyed
Sunbrella Carnegie Celeste	8065-0000	\$24.38	5.45 x 0.00	54	100% Acrylic - Solution Dyed
Sunbrella Dupione Celeste	8067-0000	\$22.53	0.00 x 0.00	54	100% Acrylic - Solution Dyed
Sunbrella Dupione Aloe	8068-0000	\$22.53	0.00 x 0.00	54	100% Acrylic - Solution Dyed
Sunbrella Dupione Dove	8069-0000	\$22.53	0.00 x 0.00	54	100% Acrylic - Solution Dyed
Sunbrella Linen Champagne	8300-0000	\$21.35	0.00 x 0.00	54	100% Acrylic - Solution Dyed
Sunbrella Linen Basil	8301-0000	\$16.87	0.00 x 0.00	54	100% Acrylic - Solution Dyed
Sunbrella Linen Natural	8304-0000	\$21.35	0.00 x 0.00	54	100% Acrylic - Solution Dyed
Sunbrella Linen Chili	8306-0000	\$16.87	0.00 x 0.00	54	100% Acrylic - Solution Dyed
Sunbrella Linen Straw	8314-0000	\$16.87	0.00 x 0.00	54	100% Acrylic - Solution Dyed
Sunbrella Linen Pampas	8317-0000	\$21.35	0.00 x 0.00	54	100% Acrylic - Solution Dyed
Sunbrella Linen Sesame	8318-0000	\$16.87	0.00 x 0.00	54	100% Acrylic - Solution Dyed
Sunbrella Linen Stone	8319-0000	\$16.87	0.00 x 0.00	54	100% Acrylic - Solution Dyed
Sunbrella Linen Antique Beige	8322-0000	\$16.87	0.00 x 0.00	54	100% Acrylic - Solution Dyed
Sunbrella Linen Silver	8351-0000	\$21.35	0.00 x 0.00	54	100% Acrylic - Solution Dyed
Sunbrella Linen Canvas	8353-0000	\$21.42	0.00 x 0.00	54	100% Acrylic - Solution Dyed
Sunbrella Berenson Tuxedo Stripe	8521-0000	\$16.87	0.00 x 4.50	54	100% Acrylic - Solution Dyed



High Point Collection™ III
of Sunbrella® Decorative Fabrics

Name	SID	Retail	Repeat Size (Inches)	Roll Width (Inches)	Materials
Sunbrella Flagship Vellum	40014-00	\$28.88	0.00 x 0.00	54	100% Acrylic - Solution Dyed
Sunbrella Flagship Plum	40014-0037	\$28.88	0.00 x 0.00	54	100% Acrylic - Solution Dyed
Sunbrella Flagship Persimmon	40014-0039	\$28.88	0.00 x 0.00	54	100% Acrylic - Solution Dyed
Sunbrella Flagship Salt	40014-0065	\$28.88	0.00 x 0.00	54	100% Acrylic - Solution Dyed
Sunbrella Flagship Papyrus	40014-02	\$28.88	0.00 x 0.00	54	100% Acrylic - Solution Dyed
Sunbrella Flagship Cocoa	40014-04	\$28.88	0.00 x 0.00	54	100% Acrylic - Solution Dyed
Sunbrella Flagship Pecan	40014-05	\$28.88	0.00 x 0.00	54	100% Acrylic - Solution Dyed
Sunbrella Flagship Black	40014-08	\$28.88	0.00 x 0.00	54	100% Acrylic - Solution Dyed
Sunbrella Flagship Mist	40014-13	\$28.88	0.00 x 0.00	54	100% Acrylic - Solution Dyed
Sunbrella Flagship Wheat	40014-17	\$28.88	0.00 x 0.00	54	100% Acrylic - Solution Dyed
Sunbrella Flagship Mango	40014-18	\$28.88	0.00 x 0.00	54	100% Acrylic - Solution Dyed
Sunbrella Flagship Celadon	40014-34	\$28.88	0.00 x 0.00	54	100% Acrylic - Solution Dyed
Sunbrella Flagship Mineral	40014-35	\$28.88	0.00 x 0.00	54	100% Acrylic - Solution Dyed
Sunbrella Flagship Stone	40014-38	\$28.88	0.00 x 0.00	54	100% Acrylic - Solution Dyed
Sunbrella Flagship Ruby	40014-44	\$28.88	0.00 x 0.00	54	100% Acrylic - Solution Dyed
Sunbrella Flagship Brick	40014-45	\$28.88	0.00 x 0.00	54	100% Acrylic - Solution Dyed
Sunbrella Flagship Gingko	40014-57	\$28.88	0.00 x 0.00	54	100% Acrylic - Solution Dyed
Sunbrella Flagship Bay Brown	40014-59	\$28.88	0.00 x 0.00	54	100% Acrylic - Solution Dyed
Sunbrella Meridian Vellum	40061-03	\$27.32	0.00 x 0.00	54	100% Acrylic - Solution Dyed
Sunbrella Meridian Dove	40061-04	\$27.32	0.00 x 0.00	54	100% Acrylic - Solution Dyed
Sunbrella Meridian Frost	40061-05	\$27.32	0.00 x 0.00	54	100% Acrylic - Solution Dyed
Sunbrella Meridian Patina	40061-06	\$27.32	0.00 x 0.00	54	100% Acrylic - Solution Dyed
Sunbrella Meridian Wren	40061-07	\$27.32	0.00 x 0.00	54	100% Acrylic - Solution Dyed
Sunbrella Meridian Cocoa	40061-08	\$27.32	0.00 x 0.00	54	100% Acrylic - Solution Dyed

High Point Collection™ III

of Sunbrella® Decorative Fabrics

Name	SID	Retail	Repeat Size (Inches)	Roll Width (Inches)	Materials
Sunbrella Meridian Mango	40061-10	\$27.32	0.00 x 0.00	54	100% Acrylic - Solution Dyed
Sunbrella Meridian Brick	40061-11	\$27.32	0.00 x 0.00	54	100% Acrylic - Solution Dyed
Sunbrella Meridian Lime	40061-13	\$27.32	0.00 x 0.00	54	100% Acrylic - Solution Dyed
Sunbrella Meridian Twilight	40061-14	\$27.32	0.00 x 0.00	54	100% Acrylic - Solution Dyed
Sunbrella Meridian Air	40061-16	\$27.32	0.00 x 0.00	54	100% Acrylic - Solution Dyed
Sunbrella Meridian Espresso	40061-18	\$27.32	0.00 x 0.00	54	100% Acrylic - Solution Dyed
Sunbrella Meridian Teak	40061-33	\$27.32	0.00 x 0.00	54	100% Acrylic - Solution Dyed
Sunbrella Meridian Charcoal	40061-34	\$27.32	0.00 x 0.00	54	100% Acrylic - Solution Dyed
Sunbrella Wyoming Redwood	40155-00	\$37.55	0.19 x 0.24	54	100% Acrylic - Solution Dyed
Sunbrella Watson Latte	40205-00	\$32.37	0.00 x 3.00	54	100% Acrylic - Solution Dyed
Sunbrella Strata Oyster	40245-0003	\$31.73	0.00 x 0.00	54	100% Acrylic - Solution Dyed
Sunbrella Strata Vellum	40245-0004	\$31.73	0.00 x 0.00	54	100% Acrylic - Solution Dyed
Sunbrella Strata Wren	40245-0005	\$31.73	0.00 x 0.00	54	100% Acrylic - Solution Dyed
Sunbrella Bangle Surfside	40247-0002	\$38.82	0.00 x 7.00	54	100% Acrylic - Solution Dyed
Sunbrella Bangle Adobe	40247-0004	\$38.82	0.00 x 7.00	54	100% Acrylic - Solution Dyed
Sunbrella Bisbee Wren	40278-0011	\$30.52	2.38 x 0.00	54	100% Acrylic - Solution Dyed
Sunbrella Bisbee Linden	40278-0013	\$30.52	2.38 x 0.00	54	100% Acrylic - Solution Dyed
Sunbrella Bisbee Charcoal	40278-0017	\$30.52	2.38 x 0.00	54	100% Acrylic - Solution Dyed
Sunbrella Forsythia Cornsilk	41010-04	\$39.67	14.13 x 31.25	54	100% Acrylic - Solution Dyed
Sunbrella Forsythia Parchment	41010-05	\$39.67	14.13 x 31.25	54	100% Acrylic - Solution Dyed
Sunbrella Canyon Wheat	42006-05	\$37.93	0.00 x 0.00	54	100% Acrylic - Solution Dyed
Sunbrella Canyon Curry	42006-11	\$37.93	0.00 x 0.00	54	100% Acrylic - Solution Dyed
Sunbrella Simone Landscape	42025-0002	\$40.47	0.38 x 2.27	54	100% Acrylic - Solution Dyed
Sunbrella Simone Flame	42025-0003	\$27.23	0.38 x 2.27	54	100% Acrylic - Solution Dyed



High Point Collection™ III
of Sunbrella® Decorative Fabrics

Name	SID	Retail	Repeat Size (Inches)	Roll Width (Inches)	Materials
Sunbrella Simone Mahogany	42025-08	\$40.47	0.38 x 2.27	54	100% Acrylic - Solution Dyed
Sunbrella Francois Teak	42033-03	\$32.31	0.95 x 1.09	54	100% Acrylic - Solution Dyed
Sunbrella Francois Redwood	42033-05	\$32.31	0.95 x 1.09	54	100% Acrylic - Solution Dyed
Sunbrella Francois Barley	42033-08	\$32.31	0.95 x 1.09	54	100% Acrylic - Solution Dyed
Sunbrella Francois Parchment	42033-09	\$32.31	0.95 x 1.09	54	100% Acrylic - Solution Dyed
Sunbrella Reel Slate	42034-00	\$39.60	6.75 x 0.00	54	100% Acrylic - Solution Dyed
Sunbrella Reel Parchment	42034-04	\$39.60	6.75 x 0.00	54	100% Acrylic - Solution Dyed
Sunbrella Cannes Flax	42035-00	\$35.98	0.00 x 0.00	54	100% Acrylic - Solution Dyed
Sunbrella Cannes Oyster	42035-0009	\$35.98	0.00 x 0.00	54	100% Acrylic - Solution Dyed
Sunbrella Charisma Dusk	42051-0000	\$53.02	3.90 x 0.00	54	100% Acrylic - Solution Dyed
Sunbrella Sasian Ginger	44036-05	\$35.34	0.00 x 0.00	54	100% Acrylic - Solution Dyed
Sunbrella Tex Granite	44049-09	\$41.21	6.63 x 4.75	54	100% Acrylic - Solution Dyed
Sunbrella Opulence Carnival	44064-01	\$37.59	10.68 x 0.00	54	100% Acrylic - Solution Dyed
Sunbrella Opulence Forest	44064-05	\$37.59	10.68 x 0.00	54	100% Acrylic - Solution Dyed
Sunbrella Limbo Parakeet	44075-03	\$36.03	14.38 x 0.00	54	100% Acrylic - Solution Dyed
Sunbrella Timbuku Charcoal	44088-04	\$32.37	9.50 x 7.18	54	100% Acrylic - Solution Dyed
Sunbrella Angela Dune	44095-00	\$39.67	14.63 x 14.30	54	100% Acrylic - Solution Dyed
Sunbrella Angela Slate	44095-01	\$39.67	14.63 x 14.30	54	100% Acrylic - Solution Dyed
Sunbrella Holmes Latte	44098-01	\$36.03	3.50 x 3.69	54	100% Acrylic - Solution Dyed
Sunbrella Holmes Cocoa	44098-02	\$36.03	3.50 x 3.69	54	100% Acrylic - Solution Dyed
Sunbrella Holmes Flannel	44098-03	\$36.03	3.50 x 3.69	54	100% Acrylic - Solution Dyed
Sunbrella Lorenzo Slate	44100-13	\$36.03	1.88 x 3.34	54	100% Acrylic - Solution Dyed
Sunbrella Posh Parchment	44157-0000	\$50.97	11.20 x 0.00	54	100% Acrylic - Solution Dyed
Sunbrella Posh Lime	44157-0002	\$50.97	11.20 x 0.00	54	100% Acrylic - Solution Dyed

High Point Collection™ III

of Sunbrella® Decorative Fabrics

Name	SID	Retail	Repeat Size (Inches)	Roll Width (Inches)	Materials
Sunbrella Posh Persimmon	44157-0003	\$50.97	11.20 x 0.00	54	100% Acrylic - Solution Dyed
Sunbrella Posh Acorn	44157-0005	\$50.97	11.20 x 0.00	54	100% Acrylic - Solution Dyed
Sunbrella Posh Oat	44157-004	\$50.97	11.20 x 0.00	54	100% Acrylic - Solution Dyed
Sunbrella Confetti Flame	45306-01	\$37.88	0.00 x 0.00	54	100% Acrylic - Solution Dyed
Sunbrella Confetti Twilight	45306-04	\$37.88	0.00 x 0.00	54	100% Acrylic - Solution Dyed
Sunbrella Nile Jungle	45349-00	\$39.67	14.25 x 14.25	54	100% Acrylic - Solution Dyed
Sunbrella Nile Cocoa	45349-01	\$39.67	14.25 x 14.25	54	100% Acrylic - Solution Dyed
Sunbrella Nile Fossil	45349-02	\$39.67	14.25 x 14.25	54	100% Acrylic - Solution Dyed
Sunbrella Bangladesh Stratosphere	45353-00	\$43.33	13.75 x 28.63	54	100% Acrylic - Solution Dyed
Sunbrella Bangladesh Dune	45353-04	\$40.50	13.75 x 28.63	54	100% Acrylic - Solution Dyed
Sunbrella Lanai Teak	45412-04	\$46.81	31.13 x 31.13	54	100% Acrylic - Solution Dyed
Sunbrella Lanai Forest	45412-05	\$46.81	31.13 x 31.13	54	100% Acrylic - Solution Dyed
Sunbrella Grove Oat	45415-0000	\$50.40	16.44 x 12.56	54	100% Acrylic - Solution Dyed
Sunbrella Grove Wren	45415-01	\$50.46	13.75 x 16.44	54	100% Acrylic - Solution Dyed
Sunbrella Rae Marie Sunset	45418-00	\$39.67	1.78 x 1.30	54	100% Acrylic - Solution Dyed
Sunbrella Leonardo Pecan	45419-00	\$43.33	14.38 x 13.88	54	100% Acrylic - Solution Dyed
Sunbrella Leonardo Mocha	45419-0005	\$43.33	13.88 x 14.38	54	100% Acrylic - Solution Dyed
Sunbrella Leonardo Clay	45419-01	\$43.33	14.38 x 13.88	54	100% Acrylic - Solution Dyed
Sunbrella Legacy Teak	45428-0001	\$50.46	28.25 x 27.56	54	100% Acrylic - Solution Dyed
Sunbrella Legacy Mango	45428-02	\$50.46	27.56 x 28.25	54	100% Acrylic - Solution Dyed
Sunbrella Legacy Kiwi	45428-03	\$50.46	27.56 x 28.25	54	100% Acrylic - Solution Dyed
Sunbrella Legacy Onyx	45428-05	\$50.46	27.56 x 28.25	54	100% Acrylic - Solution Dyed
Sunbrella Bukhara Russet	45534-0000	\$53.02	27.62 x 0.00	54	100% Acrylic - Solution Dyed
Sunbrella Allure Dusk	45543-0000	\$53.02	27.14 x 27.86	54	100% Acrylic - Solution Dyed



High Point Collection™ III
of Sunbrella® Decorative Fabrics

Name	SID	Retail	Repeat Size (Inches)	Roll Width (Inches)	Materials
Sunbrella Renewal Linden	45585-0000	\$53.02	13.62 x 26.75	54	100% Acrylic - Solution Dyed
Sunbrella Royce Garden	45626-0001	\$61.20	14.00 x 0.00	54	100% Acrylic - Solution Dyed
Sunbrella Aries Spring	45629-0000	\$61.20	27.00 x 0.00	54	100% Acrylic - Solution Dyed
Sunbrella Hoopla Kiwi	46008-05	\$68.56	0.94 x 1.04	54	100% Acrylic - Solution Dyed
Sunbrella Hoopla Cocoa	46008-12	\$68.56	0.94 x 1.04	54	100% Acrylic - Solution Dyed
Sunbrella Hoopla Nugget	46008-16	\$68.56	0.94 x 1.04	54	100% Acrylic - Solution Dyed
Sunbrella Hoopla Blue Haze	46008-19	\$68.56	0.94 x 1.04	54	100% Acrylic - Solution Dyed
Sunbrella Palace Fiesta	46028-0000	\$49.46	0.00 x 0.00	54	100% Acrylic - Solution Dyed
Sunbrella Plush Oatmeal	70011-00	\$46.81	0.00 x 0.00	54	100% Acrylic - Solution Dyed
Sunbrella Plush Wren	70011-0008	\$46.81	0.00 x 0.00	54	100% Acrylic - Solution Dyed
Sunbrella Plush Maize	70011-01	\$43.75	0.00 x 0.00	54	100% Acrylic - Solution Dyed
Sunbrella Plush Earth	70011-02	\$46.81	0.00 x 0.00	54	52% Polyester, 48% Rayon
Sunbrella Plush Sable	70011-05	\$43.75	0.00 x 0.00	54	100% Acrylic - Solution Dyed
Sunbrella Plush Spa	70011-06	\$43.75	0.00 x 0.00	54	100% Acrylic - Solution Dyed
Sunbrella Plush Patina	70011-07	\$43.75	0.00 x 0.00	54	100% Acrylic - Solution Dyed
Sunbrella Vibe Earthen	73013-0002	\$95.56	14.12 x 54.75	54	100% Acrylic - Solution Dyed



ROBERT ALLEN

Name	SID	Retail	Repeat Size (Inches)	Roll Width (Inches)	Materials
Robert Allen Tybee Island Sorbet	161228	\$28.97	2.75 x 0.00	55	65% Polyester, 35% Acrylic
Seaport Floral Daylily	174283	\$21.67	27.00 x 18.00	54	100% Acrylic - Solution Dyed
Robert Allen Lenox Lounge Fennel	RA-137779	\$18.58	13.50 x 12.75	54	100% Cotton
Robert Allen Pesaro Bk Truffle	RA-141576	\$20.29	0.00 x 0.00	59	58% Rayon, 42% Polyester
Robert Allen Success Stone	RA-145002	\$16.96	0.00 x 0.00	59	100% Cotton
Robert Allen Success Jute	RA-145003	\$16.96	0.00 x 0.00	59	100% Cotton
Robert Allen Success Fennel	RA-145020	\$16.96	0.00 x 0.00	59	100% Cotton
Robert Allen Success Pear	RA-145021	\$16.96	0.00 x 0.00	59	100% Cotton
Robert Allen Dune Stripe Seafoam	RA-146435	\$16.63	6.75 x 0.00	54	100% Cotton
Robert Allen Dune Stripe Cedar Cove	RA-146436	\$16.63	6.75 x 0.00	54	100% Cotton
Robert Allen Pickaflower Bk Sand	RA-148777	\$19.07	14.00 x 32.50	56	55% Polyester, 45% Rayon
Robert Allen Pickaflower Bk Salmon	RA-148905	\$19.07	14.00 x 32.50	56	55% Polyester, 45% Rayon
Robert Allen Pickaflower Bk Fatigue	RA-148906	\$19.07	14.00 x 32.50	56	55% Polyester, 45% Rayon
Robert Allen Coral Cove Bk Sand	RA-149522	\$21.91	18.50 x 42.00	57	98% Polyester, 2% Nylon
Robert Allen Coral Cove Bk Smoke	RA-149525	\$21.91	18.50 x 42.00	57	98% Polyester, 2% Nylon
Robert Allen Bohemian Bk Muir Woods	RA-149704	\$19.39	14.50 x 15.00	57	72% Rayon, 28% Polyester
Robert Allen Bohemian Bk Tuscan Red	RA-149705	\$19.39	14.50 x 15.00	57	72% Rayon, 28% Polyester
Robert Allen Haystack Bk Maize	RA-150856	\$16.14	0.00 x 0.00	55	100% Polyester
Robert Allen Haystack Bk Dusk	RA-150861	\$16.14	0.00 x 0.00	55	100% Polyester
Robert Allen Haystack Bk Chili	RA-150865	\$16.14	0.00 x 0.00	55	100% Polyester
Robert Allen Pashmina Bk Teatree	RA-151161	\$17.45	13.50 x 17.75	54	100% Polyester
Robert Allen Pashmina Bk Frankincense	RA-151164	\$17.45	13.50 x 17.75	54	100% Polyester
Robert Allen Vanessa Stripe Bay Leaf	RA-151193	\$24.25	7.00 x 0.00	54	59% Cotton, 41% Polyester
Robert Allen Planetary Rrbk Henna	RA-151203	\$17.76	13.50 x 13.50	54	55% Cotton, 45% Polyester
Robert Allen Planetary Rrbk Mineral	RA-151206	\$17.76	13.50 x 13.50	54	55% Cotton, 45% Polyester

ROBERT ALLEN

Name	SID	Retail	Repeat Size (Inches)	Roll Width (Inches)	Materials
Robert Allen Dizzied Up Bk Spa	RA-152748	\$17.45	13.50 x 14.00	54	50% Polyester, 50% Rayon
Robert Allen Pontoise Noir	RA-154954	\$17.76	27.00 x 27.00	54	100% Cotton
Robert Allen Floored Sandstone	RA-159640	\$15.42	4.50 x 4.50	54	61% Cotton, 39% Polyester
Robert Allen Floored Patina	RA-159642	\$15.42	4.50 x 4.50	54	61% Cotton, 39% Polyester
Robert Allen Filaree Canyon	RA-170011	\$22.63	7.00 x 10.50	55	68% Viscose, 32% Polyester
Robert Allen Filaree Hazelnut	RA-170013	\$22.63	7.00 x 10.50	55	68% Viscose, 32% Polyester
Robert Allen Regatta Club Atlantic	RA-173306	\$20.29	27.00 x 25.25	54	100% Acrylic
Robert Allen North Haven Cayenne	RA-174146	\$23.45	13.50 x 16.25	54	59% Rayon, 16% Cotton, 25% Polyester
Robert Allen Tex Weave Gold	RA-174509	\$24.74	0.00 x 0.00	54	60% Polyester, 26% Cotton
Robert Allen Rowlily Palm Beach	RA-174641	\$20.20	27.00 x 27.00	54	55% Linen, 45% Rayon
Robert Allen Big Cat Desert Sand	RA-176315	\$21.01	18.00 x 6.75	55	70% Rayon, 13% Cotton, 17% Polyester
Robert Allen Big Cat Ember	RA-176316	\$21.01	18.00 x 6.75	55	70% Rayon, 13% Cotton, 17% Polyester
Robert Allen Big Cat Smoke	RA-176318	\$21.01	18.00 x 6.75	55	70% Rayon, 13% Cotton, 17% Polyester
Robert Allen Sheshimmers Cafe	RA-176346	\$20.20	27.00 x 27.00	54	55% Linen, 45% Rayon
Robert Allen Rowlily Caribe	RA-176933	\$20.20	27.00 x 27.00	54	55% Linen, 45% Rayon
Robert Allen Rowlily Jungle	RA-176935	\$20.20	27.00 x 27.00	54	55% Linen, 45% Rayon
Robert Allen Peony Call Parchment	RA-179100	\$16.96	27.00 x 27.00	54	100% Cotton
Robert Allen Fortune Sticks Cafe	RA-179592	\$25.56	27.00 x 28.75	58	52% Rayon, 19% Polyester
Robert Allen Peony Call Spa	RA-181075	\$16.96	27.00 x 27.00	54	100% Cotton
Robert Allen Peony Call Tourmaline	RA-181076	\$16.96	27.00 x 27.00	54	100% Cotton
Robert Allen Umma Shawl Gold Dust	RA-181322	\$21.91	28.00 x 28.00	55	66% Rayon, 34% Polyester
Robert Allen Bali Batik Mosaic	RA-181373	\$21.01	13.50 x 12.25	55	66% Rayon, 34% Polyester
Robert Allen Bali Batik Jewel	RA-181375	\$21.01	13.50 x 12.25	55	66% Rayon, 34% Polyester
Robert Allen Bali Batik Sorbet	RA-181376	\$21.01	13.50 x 12.25	55	66% Rayon, 34% Polyester



ROBERT ALLEN

Name	SID	Retail	Repeat Size (Inches)	Roll Width (Inches)	Materials
Robert Allen Tuscan Scroll Linen	RA-181422	\$22.63	13.50 x 10.50	54	75% Rayon, 25% Polyester
Robert Allen Tuscan Scroll Iron	RA-181429	\$22.63	13.50 x 10.50	54	75% Rayon, 25% Polyester
Robert Allen Eden Lampasso Spa	RA-181725	\$21.91	24.50 x 29.50	59	69% Rayon, 31% Polyester
Robert Allen Villa Stripe Spa	RA-181734	\$21.01	5.00 x 0.00	55	60% Linen, 40% Cotton
Robert Allen Umma Shawl Noir	RA-182496	\$21.91	28.00 x 28.00	55	66% Rayon, 34% Polyester
Robert Allen Lilith Spring	RA-184071	\$16.14	27.00 x 27.00	55	100% Cotton
Robert Allen Paisley Fleur Pearl	RA-184989	\$21.50	7.00 x 7.50	56	66% Rayon, 34% Polyester
Robert Allen Paisley Fleur Spice	RA-184993	\$21.50	7.00 x 7.50	56	66% Rayon, 34% Polyester
Robert Allen Outline Birch	RA-185055	\$24.25	1.75 x 0.00	55	100% Polyester
Robert Allen Outline Vermillion	RA-185057	\$24.25	1.75 x 0.00	55	100% Polyester
Robert Allen Leaf Berry Stone	RA-185244	\$22.63	14.00 x 27.00	54	75% Rayon, 25% Polyester
Robert Allen Royal Chevron Cloud	RA-185331	\$30.02	1.25 x 0.00	55	85% Rayon, 15% Polyester
Robert Allen Waldemere Dove	RA-185338	\$17.76	27.00 x 27.00	54	100% Cotton
Robert Allen Sperling Iris	RA-185355	\$17.76	27.00 x 13.50	54	100% Cotton
Robert Allen Khandar Cinnabar	RA-185909	\$17.76	27.00 x 27.00	54	100% Cotton
Robert Allen Waldemere Iris	RA-185982	\$17.76	27.00 x 27.00	54	100% Cotton
Robert Allen Waldemere Noir	RA-185983	\$17.76	27.00 x 27.00	54	100% Cotton
Robert Allen Freewater Teastain	RA-186035	\$16.14	13.50 x 0.00	54	100% Cotton
Robert Allen Freewater Aqua	RA-186037	\$16.14	13.50 x 0.00	54	100% Cotton
Robert Allen Freewater Capri	RA-186038	\$16.14	13.50 x 0.00	54	100% Cotton
Robert Allen Meadowview Capri	RA-186041	\$16.14	27.00 x 27.00	54	100% Cotton
Robert Allen Kukula Azure	RA-186057	\$17.76	27.25 x 0.00	54	100% Cotton
Robert Allen Kiki Azure	RA-186058	\$17.76	27.00 x 27.00	54	100% Cotton
Robert Allen Square Pegs Noir	RA-186530	\$29.12	1.50 x 1.50	55	100% Cotton
Robert Allen Khandar Indigo	RA-186675	\$17.76	27.00 x 27.00	54	100% Cotton
Robert Allen Kiki Pinata	RA-188835	\$17.76	27.00 x 27.00	54	100% Cotton

ROBERT ALLEN

Name	SID	Retail	Repeat Size (Inches)	Roll Width (Inches)	Materials
Robert Allen Kukula Pinata	RA-188838	\$17.76	27.25 x 0.00	54	100% Cotton
Robert Allen Kathandi Cinabar/Polyoxf	RA-189492	\$12.58	13.50 x 13.50	54	100% Polyester
Robert Allen Alpha Weave Redwood	RA-190852	\$20.20	0.00 x 0.00	54	100% Polyester
Robert Allen Alpha Weave Sisal	RA-190853	\$20.20	0.00 x 0.00	54	100% Polyester
Robert Allen Alpha Weave Cinder	RA-190854	\$20.20	0.00 x 0.00	54	100% Polyester
Robert Allen Alpha Weave Vapor	RA-190855	\$20.20	0.00 x 0.00	54	100% Polyester
Robert Allen Cats Cradle River	RA-190966	\$19.39	3.25 x 3.25	55	55% Linen, 45% Rayon
Robert Allen Cats Cradle Grass	RA-190968	\$19.39	3.25 x 3.25	55	55% Linen, 45% Rayon
Robert Allen Halmstad Graphite	RA-191003	\$19.39	13.50 x 25.25	54	100% Cotton
Robert Allen Les Fauves Grasslands	RA-191036	\$20.20	27.00 x 27.00	54	55% Linen, 45% Rayon
Robert Allen Botany Flora Leaf	RA-193478	\$16.96	13.50 x 27.00	54	100% Cotton
Robert Allen Maze Work Azure	RA-193480	\$16.96	1.00 x 1.80	54	100% Cotton
Robert Allen Square Lattice Hydrangea	RA-193482	\$16.96	5.25 x 5.25	54	100% Cotton
Robert Allen Canvas Duck Eggshell	RA-193551	\$16.14	0.00 x 0.00	54	100% Cotton
Robert Allen Canvas Duck Sand	RA-193553	\$16.14	0.00 x 0.00	54	100% Cotton
Robert Allen Canvas Duck Mink	RA-193554	\$16.14	0.00 x 0.00	54	100% Cotton
Robert Allen Canvas Duck Bark	RA-193556	\$16.14	0.00 x 0.00	54	100% Cotton
Robert Allen Canvas Duck Chocolate	RA-193558	\$16.14	0.00 x 0.00	54	100% Cotton
Robert Allen Canvas Duck Crimson	RA-193563	\$16.14	0.00 x 0.00	54	100% Cotton
Robert Allen Canvas Duck Chamois	RA-193565	\$16.14	0.00 x 0.00	54	100% Cotton
Robert Allen Canvas Duck Leaf	RA-193568	\$16.14	0.00 x 0.00	54	100% Cotton
Robert Allen Canvas Duck Fog	RA-193579	\$16.14	0.00 x 0.00	54	100% Cotton
Robert Allen Canvas Duck Onyx	RA-193582	\$16.14	0.00 x 0.00	54	100% Cotton
Robert Allen Tweedy Natural Black	RA-193650	\$20.20	0.00 x 0.00	54	65% Polyester, 35% Cotton



ROBERT ALLEN

Name	SID	Retail	Repeat Size (Inches)	Roll Width (Inches)	Materials
Robert Allen Brushed Basket Azure	RA-193739	\$18.58	4.50 x 8.50	55	100% Cotton
Robert Allen Dotscape Charcoal	RA-193826	\$19.39	2.75 x 2.75	54	100% Cotton
Robert Allen Velvet Geo Grey	RA-193840	\$28.80	1.75 x 1.50	54	60% Polyester, 40% Rayon
Robert Allen Scenic Flora Tapestry	RA-193866	\$13.71	27.00 x 27.00	54	55% Linen, 45% Rayon
Robert Allen Tropic Scene Capri	RA-193872	\$19.39	13.50 x 25.25	55	100% Cotton
Robert Allen Tropic Scene Sunshine	RA-193873	\$19.39	13.50 x 25.25	55	100% Cotton
Robert Allen Tupper Island Marine	RA-193941	\$20.29	13.50 x 13.50	54	100% Cotton
Robert Allen Valarelli Oat	RA-195219	\$40.17	4.25 x 6.25	55	100% Polyester
Robert Allen Valarelli Walnut	RA-195220	\$40.17	4.25 x 6.25	55	100% Polyester
Robert Allen Valarelli Stone	RA-195221	\$40.17	4.25 x 6.25	55	100% Polyester
Robert Allen Circle Rings Espresso	RA-195222	\$39.59	2.50 x 2.75	59	100% Polyester
Robert Allen Circle Rings Birch	RA-195223	\$39.59	2.50 x 2.75	59	100% Polyester
Robert Allen Circle Rings Natural	RA-195225	\$39.59	2.50 x 2.75	59	100% Polyester - Treated
Robert Allen Boscastle Terrain	RA-195242	\$31.09	14.75 x 35.00	58	55% Polyester, 45% Rayon
Robert Allen Pretty Posy Champagne	RA-195244	\$33.68	26.00 x 23.00	58	100% Polyester
Robert Allen Formal Living Biscotti	RA-195261	\$18.82	14.00 x 12.00	57	60% Cotton, 40% Polyester
Robert Allen Formal Living Camel	RA-195262	\$18.82	14.00 x 12.00	57	60% Cotton, 40% Polyester
Robert Allen Pickard Graphite	RA-195266	\$24.60	0.00 x 0.00	54	100% Polyester
Robert Allen Pickard Feldspar	RA-195267	\$24.60	0.00 x 0.00	54	100% Polyester
Robert Allen Billings Camel	RA-195280	\$22.00	10.00 x 0.00	59	100% Polyester
Robert Allen Spray Beach Cinder	RA-195748	\$19.39	13.50 x 13.50	55	100% Cotton
Robert Allen Velvet Geo Truffle	RA-196190	\$28.80	1.75 x 1.50	54	60% Polyester, 40% Rayon
Robert Allen Velvet Geo Citrine	RA-196192	\$28.80	1.75 x 1.50	54	60% Polyester, 40% Rayon
Robert Allen Oak Island Grey	RA-196320	\$21.01	6.50 x 0.00	55	55% Viscose, 45% Cotton
Robert Allen Tweedy Jade	RA-196393	\$20.20	0.00 x 0.00	54	65% Polyester, 35% Cotton

ROBERT ALLEN

Name	SID	Retail	Repeat Size (Inches)	Roll Width (Inches)	Materials
Robert Allen Tweedy Dove	RA-196395	\$20.20	0.00 x 0.00	54	65% Polyester, 35% Cotton
Robert Allen Tweedy Major Brown	RA-196396	\$20.20	0.00 x 0.00	54	65% Polyester, 35% Cotton
Robert Allen Boteh Jade	RA-196487	\$20.29	9.00 x 9.00	54	100% Cotton
Robert Allen Dotscape Major Brown	RA-196497	\$19.39	2.75 x 2.75	54	100% Cotton
Robert Allen Oak Island Cinder	RA-196540	\$21.01	6.50 x 0.00	55	55% Viscose, 45% Cotton
Robert Allen Thatcher Island Seaglass	RA-196588	\$19.39	9.00 x 18.00	55	100% Cotton
Robert Allen Crystal Springs Seaglass	RA-196601	\$20.29	13.50 x 27.00	55	100% Cotton
Robert Allen Reed River Driftwood	RA-196620	\$20.29	13.50 x 6.50	55	100% Cotton
Robert Allen Tupper Island Seaglass	RA-196621	\$20.29	13.50 x 13.50	54	100% Cotton
Robert Allen Canton Lake Seaglass	RA-196622	\$20.29	6.75 x 6.75	55	100% Cotton
Robert Allen Blocks N Dots Aqua	RA-196653	\$31.09	1.50 x 4.00	58	100% Polyester
Robert Allen Blocks N Dots Pistachio	RA-196656	\$31.09	1.50 x 4.00	58	100% Polyester
Robert Allen Flowing Freely Chai	RA-196661	\$38.88	17.00 x 9.50	55	100% Polyester
Robert Allen Flowing Freely Sterling	RA-196662	\$38.88	17.00 x 9.50	55	100% Polyester
Robert Allen Nim Nutmeg	RA-196665	\$27.19	0.00 x 0.00	58	100% Polyester
Robert Allen Nim Henna	RA-196666	\$27.19	0.00 x 0.00	58	100% Polyester
Robert Allen Georgia Stripe Olive	RA-196686	\$29.79	6.75 x 0.00	55	100% Polyester
Robert Allen Georgia Stripe Mango	RA-196687	\$29.79	6.75 x 0.00	55	100% Polyester
Robert Allen Georgia Stripe Tide	RA-196688	\$29.79	6.75 x 0.00	55	100% Polyester
Robert Allen Georgia Stripe Willow	RA-196689	\$29.79	6.75 x 0.00	55	100% Polyester
Robert Allen Ribbon Boxes Seafoam	RA-196701	\$31.09	0.00 x 0.00	54	100% Polyester
Robert Allen Art Scene Mahogany	RA-196711	\$28.49	14.00 x 18.00	55	100% Cotton
Robert Allen Art Scene Green Tea	RA-196718	\$28.49	14.00 x 18.00	55	100% Cotton
Robert Allen Faded Swirls Koi	RA-196729	\$28.49	13.50 x 26.50	55	100% Cotton
Robert Allen Swirl Lane Jungle	RA-196744	\$28.49	25.50 x 14.00	55	100% Cotton



ROBERT ALLEN

Name	SID	Retail	Repeat Size (Inches)	Roll Width (Inches)	Materials
Robert Allen Snake Chain Brindle	RA-196960	\$66.20	6.75 x 13.50	54	100% Linen
Robert Allen Stony River Cinder	RA-196962	\$23.45	0.00 x 0.00	55	80% Polyester, 20% Cotton
Robert Allen Stony River Marine	RA-196965	\$23.45	0.00 x 0.00	55	80% Polyester, 20% Cotton
Robert Allen Baron Lake Marine	RA-197344	\$26.36	4.50 x 0.00	55	100% Cotton
Robert Allen Baron Lake Cinder	RA-197347	\$26.36	4.50 x 0.00	55	100% Cotton
Robert Allen Baron Lake Seaglass	RA-197348	\$26.36	4.50 x 0.00	55	100% Cotton
Robert Allen Patch Poppy	RA-197541	\$32.39	6.75 x 7.00	54	100% Polyester
Robert Allen Glam Sheen Jute	RA-198052	\$20.69	0.00 x 0.00	55	75% Polyester, 25% Cotton
Robert Allen Glam Sheen Dove	RA-198053	\$20.69	0.00 x 0.00	55	75% Polyester, 25% Cotton
Robert Allen Glam Sheen Slate	RA-198055	\$20.69	0.00 x 0.00	55	75% Polyester, 25% Cotton
Robert Allen Glam Sheen Java	RA-198056	\$20.69	0.00 x 0.00	55	75% Polyester, 25% Cotton
Robert Allen Sunscape Tropic	RA-198318	\$12.90	27.00 x 27.00	54	100% Cotton
Robert Allen Latticescape Hibiscus	RA-198320	\$12.90	3.50 x 3.50	54	100% Cotton
Robert Allen Latticescape Onyx	RA-198321	\$14.20	3.50 x 3.50	54	100% Cotton
Robert Allen Latticescape Java	RA-198322	\$12.90	3.50 x 3.50	54	100% Cotton
Robert Allen Stripescape Island Sea	RA-198323	\$14.20	25.25 x 13.50	54	100% Cotton
Robert Allen Tuscan Ikat Bk Jute	RA-198492	\$25.07	4.00 x 7.00	54	60% Cotton, 40% Polyester
Robert Allen Tweedy Bronze	RA-199654	\$20.20	0.00 x 0.00	54	65% Polyester, 35% Cotton
Robert Allen Baja Stripe Poppy	RA-207628	\$12.90	25.25 x 13.50	54	100% Polyester
Robert Allen Baja Floral Fiesta	RA-207635	\$12.90	27.00 x 27.00	54	100% Polyester
Robert Allen Baja Leaves Navy	RA-207636	\$12.90	13.50 x 13.50	54	100% Polyester
Robert Allen Baja Floral Turquoise	RA-207644	\$12.90	27.00 x 27.00	54	100% Polyester
Robert Allen Baja Floral Lemon	RA-207646	\$12.90	27.00 x 27.00	54	100% Polyester
Robert Allen Baja Leaves Turquoise	RA-207647	\$12.90	13.50 x 13.50	54	100% Polyester
Robert Allen Baja Plaid Turquoise	RA-207649	\$12.90	9.00 x 9.00	54	100% Polyester

ROBERT ALLEN

Name	SID	Retail	Repeat Size (Inches)	Roll Width (Inches)	Materials
Robert Allen Baja Plaid Lemon	RA-207651	\$12.90	9.00 x 9.00	54	100% Polyester
Robert Allen Baja Stripe Turquoise	RA-207652	\$12.90	25.25 x 13.50	54	100% Polyester
Mellow Stripe Magenta	RA-214137	\$46.66	2.75 x 0.00	54	86% Rayon, 14% Polyester - Untreated
Robert Allen Center Square Magenta	RA-214457	\$46.66	14.00 x 19.00	55	100% Polyester
Robert Allen Dragon Lizard Twine	RA-214519	\$51.85	7.00 x 7.50	58	54% Rayon, 46% Cotton
Robert Allen Velvet Geo Magenta	RA-217389	\$28.80	1.75 x 1.50	54	60% Polyester, 40% Rayon
Robert Allen Padgetville Sunblue	RA-45590	\$17.76	9.00 x 9.00	54	100% Acrylic
Robert Allen Success Noir	RA-81789	\$16.96	0.00 x 0.00	59	100% Cotton
Robert Allen Success Navy	RA-81790	\$16.96	0.00 x 0.00	59	100% Cotton
Robert Allen Success Dune	RA-81799	\$16.96	0.00 x 0.00	59	100% Cotton
Robert Allen Success Currant	RA-81819	\$16.96	0.00 x 0.00	59	100% Cotton
Robert Allen Success Natural	RA-81825	\$16.96	0.00 x 0.00	59	100% Cotton
Robert Allen Success Java	RA-85948	\$16.96	0.00 x 0.00	59	100% Cotton
Robert Allen Success Graphite	RA-85949	\$16.96	0.00 x 0.00	59	100% Cotton
Robert Allen Success Teal	RA-86208	\$16.96	0.00 x 0.00	59	100% Cotton
Robert Allen Success Putty	RA-86212	\$16.96	0.00 x 0.00	59	100% Cotton



Name	SID	Retail	Repeat Size (Inches)	Roll Width (Inches)	Materials
Outdura Serenade Natural	310	\$31.65	0.25 x 0.50	54	100% Acrylic - Solution Dyed
Outdura Serenade Sisal	311	\$31.65	0.25 x 0.50	54	100% Acrylic - Solution Dyed
Outdura Serenade Chocolate	312	\$31.65	0.25 x 0.50	54	100% Acrylic - Solution Dyed
Outdura Charade Stone	703	\$32.29	0.25 x 0.50	54	100% Acrylic - Solution Dyed
Outdura Bravo Sisal	1551	\$33.92	0.00 x 0.00	54	100% Acrylic - Solution Dyed
Outdura Bravo Palm	1556	\$33.92	0.00 x 0.00	54	100% Acrylic - Solution Dyed
Outdura Sparkle Skipper	1704	\$14.30	0.00 x 0.00	54	100% Acrylic - Solution Dyed
Outdura Sparkle Birch	1706	\$15.09	0.00 x 0.00	54	100% Acrylic - Solution Dyed
Outdura Sparkle Buttercup	1712	\$15.09	0.00 x 0.00	54	100% Acrylic - Solution Dyed
Outdura Sparkle Pottery	1714	\$15.08	0.00 x 0.00	54	100% Acrylic - Solution Dyed
Outdura Sparkle Terra	1717	\$15.09	0.00 x 0.00	54	100% Acrylic - Solution Dyed
Outdura Sparkle Cork	1720	\$15.09	0.00 x 0.00	54	100% Acrylic - Solution Dyed
Outdura Sparkle Nautical	1723	\$15.09	0.00 x 0.00	54	100% Acrylic - Solution Dyed
Outdura Sparkle Silver	1725	\$15.09	0.00 x 0.00	54	100% Acrylic - Solution Dyed
Outdura Sparkle Navy Blue	1726	\$15.09	0.00 x 0.00	54	100% Acrylic - Solution Dyed
Outdura Scoop Seamist	1900	\$18.82	0.00 x 0.00	54	100% Acrylic - Solution Dyed
Outdura Scoop Birch	1901	\$18.06	0.00 x 0.00	54	100% Acrylic - Solution Dyed
Outdura Scoop Jute	1903	\$18.82	0.00 x 0.00	54	100% Acrylic - Solution Dyed
Outdura Scoop Timber	1904	\$18.82	0.00 x 0.00	54	100% Acrylic - Solution Dyed
Outdura Scoop Pesto	1906	\$18.82	0.00 x 0.00	54	100% Acrylic - Solution Dyed
Outdura Scoop Fern	1908	\$18.82	0.00 x 0.00	54	100% Acrylic - Solution Dyed
Outdura Scoop Chili	1911	\$18.82	0.00 x 0.00	54	100% Acrylic - Solution Dyed
Outdura Scoop Sailor	1917	\$18.82	0.00 x 0.00	54	100% Acrylic - Solution Dyed
Outdura Scoop Brick	1919	\$18.82	0.00 x 0.00	54	100% Acrylic - Solution Dyed



Name	SID	Retail	Repeat Size (Inches)	Roll Width (Inches)	Materials
Outdura Scoop Sapphire	1920	\$18.82	0.00 x 0.00	54	100% Acrylic - Solution Dyed
Outdura Jinga Coffee	201J	\$19.47	3.38 x 0.00	54	100% Acrylic - Solution Dyed
Outdura Jinga Sienna	209J	\$19.47	3.38 x 0.00	54	100% Acrylic - Solution Dyed
Outdura Gazebo Palm	2150	\$37.16	27.75 x 18.00	54	100% Acrylic - Solution Dyed
Outdura Gazebo Kona	2151	\$36.99	27.75 x 18.00	54	100% Acrylic - Solution Dyed
Outdura Gazebo Oats	2153	\$36.99	27.75 x 18.00	54	100% Acrylic - Solution Dyed
Outdura Spellbound Coal	2251	\$36.99	13.88 x 13.50	54	100% Acrylic - Solution Dyed
Outdura Terrace Brick	3353	\$19.47	4.50 x 0.00	54	100% Acrylic - Solution Dyed
Outdura Moritz Citrine	3451	\$33.43	13.50 x 9.00	54	100% Acrylic - Solution Dyed
Outdura Marrakech Salsa	3551	\$33.88	13.50 x 13.50	54	100% Acrylic - Solution Dyed
Outdura Marrakech Espresso	3552	\$35.54	13.50 x 13.50	54	100% Acrylic - Solution Dyed
Outdura Marrakech Nautical	3557	\$35.54	13.50 x 13.50	54	100% Acrylic - Solution Dyed
Outdura Wild Thing Mandarin	3652	\$33.10	6.75 x 6.75	54	100% Acrylic - Solution Dyed
Outdura Wild Thing Walnut	3653	\$33.10	6.75 x 6.75	54	100% Acrylic - Solution Dyed
Outdura Wild Thing Platinum	3655	\$33.10	6.75 x 6.75	54	100% Acrylic - Solution Dyed
Outdura Encore Oats	3751	\$32.78	0.12 x 2.50	54	100% Acrylic - Solution Dyed
Outdura Tradewinds Marsh	3803	\$19.47	0.00 x 9.00	54	100% Acrylic - Solution Dyed
Outdura Tradewinds Nautical	3805	\$19.47	0.00 x 9.00	54	100% Acrylic - Solution Dyed
Outdura Tradewinds Laguna	3806	\$19.47	0.00 x 9.00	54	100% Acrylic - Solution Dyed
Outdura Tradewinds Allspice	3807	\$19.47	0.00 x 9.00	54	100% Acrylic - Solution Dyed
Outdura Incline Ivory	4307	\$19.47	0.00 x 0.00	54	100% Acrylic - Solution Dyed
Outdura Incline Spa	4308	\$19.47	0.00 x 0.00	54	100% Acrylic - Solution Dyed
Outdura Incline Kona	4313-2	\$19.47	0.00 x 0.00	54	100% Acrylic - Solution Dyed
Outdura Incline Black	4314	\$19.47	0.00 x 0.00	54	100% Acrylic - Solution Dyed



Name	SID	Retail	Repeat Size (Inches)	Roll Width (Inches)	Materials
Outdura Incline Neptune	4317	\$19.47	0.00 x 0.00	54	100% Acrylic - Solution Dyed
Outdura Incline Natural White	4320	\$19.47	0.00 x 0.00	54	100% Acrylic - Solution Dyed
Outdura Incline Sandstone	4325	\$19.63	0.00 x 0.00	54	100% Acrylic - Solution Dyed
Outdura Incline Golden	4326	\$19.47	0.00 x 0.00	54	100% Acrylic - Solution Dyed
Outdura Incline Fern	4327	\$19.47	0.00 x 0.00	54	100% Acrylic - Solution Dyed
Outdura Incline Captain Navy	4331	\$19.47	0.00 x 0.00	54	100% Acrylic - Solution Dyed
Outdura Bongo Chocolate	450B-2	\$34.38	6.88 x 6.75	54	100% Acrylic - Solution Dyed
Outdura Bongo Alloy	454B	\$35.86	6.88 x 6.75	54	100% Acrylic - Solution Dyed
Outdura Pursuit Aqua	4750	\$19.47	0.00 x 13.50	54	100% Acrylic - Solution Dyed
Outdura Pursuit Agate	4752	\$19.47	0.00 x 13.50	54	100% Acrylic - Solution Dyed
Outdura Pursuit Blueridge	4754	\$18.18	0.00 x 13.50	54	100% Acrylic - Solution Dyed
Outdura Pursuit Orchard	4755	\$19.47	13.50 x 0.00	54	100% Acrylic - Solution Dyed
Outdura Raffia Cayenne	4904	\$37.82	0.00 x 0.00	54	100% Acrylic - Solution Dyed
Outdura Raffia Poppy	4912	\$35.70	0.00 x 0.00	54	100% Acrylic - Solution Dyed
Outdura Pasha Oxide	5342	\$46.57	28.00 x 23.75	54	100% Acrylic - Solution Dyed
Outdura Pasha Platinum	5347	\$46.57	28.00 x 23.75	54	100% Acrylic - Solution Dyed
Outdura Canary	5424	\$19.47	0.00 x 0.00	54	100% Acrylic - Solution Dyed
Outdura Olive	5428	\$21.40	0.00 x 0.00	54	100% Acrylic - Solution Dyed
Outdura Paprika	5429	\$21.72	0.00 x 0.00	54	100% Acrylic - Solution Dyed
Outdura Trellis Olive	5550	\$24.18	0.50 x 0.75	54	100% Acrylic - Solution Dyed
Outdura Trellis Aspen	5551	\$24.18	0.50 x 0.75	54	100% Acrylic - Solution Dyed
Outdura Trellis Sailor	5557	\$24.18	0.50 x 0.75	54	100% Acrylic - Solution Dyed
Outdura Skyline Seamist	5702	\$18.42	0.00 x 4.50	54	100% Acrylic - Solution Dyed
Outdura Fortune Mocha	6704	\$24.18	2.25 x 2.50	54	100% Acrylic - Solution Dyed



Name	SID	Retail	Repeat Size (Inches)	Roll Width (Inches)	Materials
Outdura Fortune Coffee	6706	\$24.18	2.25 x 2.50	54	100% Acrylic - Solution Dyed
Outdura Junction Salsa	7052	\$19.80	9.00 x 0.00	54	100% Acrylic - Solution Dyed
Outdura Bay Street Skipper	7901	\$20.79	0.00 x 6.75	54	100% Acrylic - Solution Dyed
Outdura Raj Hemp	8151	\$24.18	0.50 x 0.50	54	100% Acrylic - Solution Dyed
Outdura Mystique Carbon	951M	\$35.86	13.88 x 27.00	54	100% Acrylic - Solution Dyed
Outdura Mystique Brick	952M	\$35.86	13.88 x 27.00	54	100% Acrylic - Solution Dyed
Outdura Pesto	LPES54.99	\$13.09	0.00 x 0.00	54	100% Acrylic - Solution Dyed



Name	SID	Retail	Repeat Size (Inches)	Roll Width (Inches)	Materials
Geobella Common Ground Tarragon	3021538	\$23.57	0.00 x 0.00	54	100% Olefin
Geobella Common Ground Pebble	3021539	\$23.57	0.00 x 0.00	54	100% Olefin
Geobella Common Ground DK Hickory	3021541	\$23.57	0.00 x 0.00	54	100% Olefin
Geobella Topsy Turvy Cayenne Claret	3021542	\$23.57	4.50 x 5.00	54	100% Olefin
Geobella Ditty Scrubgum Brown	3021544	\$23.57	0.00 x 0.00	54	100% Olefin
Geobella Ditty Henna Claret	3021545	\$23.57	0.00 x 0.00	54	100% Olefin
Geobella Linen Basket	3022070	\$23.57	0.00 x 0.00	54	100% Olefin
Geobella Ashland	3024093	\$23.57	2.40 x 2.00	54	100% Olefin
Geobella Cordoba	3024094	\$23.57	13.50 x 13.50	54	100% Olefin
Geobella Twist Spice	3024099	\$23.57	0.00 x 0.00	54	100% Olefin
Geobella Twist Celery	3024100	\$23.57	0.00 x 0.00	54	100% Olefin
Geobella Caribbean Plum Sage	3024933	\$25.61	28.00 x 27.00	54	100% Olefin
Geobella Houndstooth	3025669	\$22.81	1.20 x 1.25	54	100% Olefin
Geobella Wandering Vine Tobacco	3025686	\$15.13	18.00 x 13.57	54	100% Olefin
Geobella Wandering Vine Light Cayenne	3025687	\$15.13	18.00 x 13.57	54	100% Olefin
Geobella Seven Mile Stripe Bark	3025688	\$15.10	0.00 x 7.20	54	100% Olefin
Geobella Iguana Cayenne	3025689	\$15.10	0.00 x 0.00	54	100% Olefin
Geobella Driftwood Cayenne	3025690	\$15.10	0.00 x 0.00	54	100% Olefin
Geobella Rock Solid Aqua	3025692	\$17.07	0.00 x 0.00	54	100% Olefin
Geobella Rock Solid Sage	3025693	\$17.07	0.00 x 0.00	54	100% Olefin
Geobella Rock Solid Cornflower	3025694	\$17.07	0.00 x 0.00	54	100% Olefin
Geobella Rock Solid Navy	3025695	\$17.07	0.00 x 0.00	54	100% Olefin
Geobella Hobnob Mist	3025696	\$17.07	0.00 x 0.00	54	100% Olefin
Geobella Rock Solid Tobacco	3025697	\$17.07	0.00 x 0.00	54	100% Olefin
Geobella Rock Solid Spice Brown	3025699	\$17.07	0.00 x 0.00	54	100% Olefin
Geobella Rock Solid Walnut	3025700	\$17.07	0.00 x 0.00	54	100% Olefin
Geobella Hobnob Tobacco	3025702	\$17.07	0.00 x 0.00	54	100% Olefin
Geobella Rock Solid Tarragon	3025703	\$17.07	0.00 x 0.00	54	100% Olefin
Geobella Rock Solid Marzipan	3025705	\$17.07	0.00 x 0.00	54	100% Olefin
Geobella Rock Solid Black	3025706	\$17.07	0.00 x 0.00	54	100% Olefin

Name	SID	Retail	Repeat Size (Inches)	Roll Width (Inches)	Materials
Geobella Rock Solid Red Pepper	3025710	\$17.07	0.00 x 0.00	54	100% Olefin
Geobella Plantain Grass	3025716	\$17.07	1.00 x 1.00	54	100% Olefin
Geobella Quickstep Spice	3025719	\$22.81	1.88 x 1.88	54	100% Olefin
Geobella Asian Dahlia Mango	3025720	\$22.81	28.00 x 13.50	54	100% Olefin
Geobella Guru Coral	3025722	\$22.81	1.60 x 3.50	54	100% Olefin
Geobella White Crest Ochre	3025723	\$22.81	3.60 x 4.65	54	100% Olefin
Geobella Jungle Beat Lagoon	3025724	\$25.61	27.00 x 27.00	54	100% Olefin
Geobella Jungle Beat Tree Frog	3025725	\$25.61	27.00 x 27.00	54	100% Olefin
Geobella Bally Castle Tobacco	3025727	\$25.61	14.00 x 14.00	54	100% Olefin
Geobella Mai Tai Daisy	3025729	\$25.61	13.50 x 14.00	54	100% Olefin
Geobella Mehindi Spice	3025731	\$25.61	26.00 x 13.50	54	100% Olefin
Geobella Conga Line Tree Frog	3025791	\$18.18	0.00 x 13.50	54	100% Olefin
Geobella Swizzle Bright	3025793	\$18.18	0.00 x 3.14	54	100% Olefin
Geobella Spice Island Stripe Spice	3025795	\$18.18	0.00 x 3.75	54	100% Olefin
Geobella Spice Island Stripe Coral	3025797	\$18.18	0.00 x 3.75	54	100% Olefin



Name	SID	Retail	Repeat Size (Inches)	Roll Width (Inches)	Materials
Amsterdam - Black	AMSTEBK	\$8.93	25.50 x 19.00	54	100% Cotton
Amsterdam - Chartreuse	AMSTECHAWH	\$8.93	25.50 x 19.00	54	100% Cotton
Amsterdam - Candy Pink	AMSTECYPK	\$8.93	25.50 x 19.00	54	100% Cotton
Canopy - Black	CANOPBK	\$8.93	0.00 x 3.00	54	100% Cotton
Canopy - Lipstick	CANOPLS	\$8.93	0.00 x 3.00	54	100% Cotton
Dandelion - White/True Turquoise	DANDEWHTT	\$8.93	12.00 x 36.00	54	100% Cotton
Desoto - Black	DESOTBK	\$8.93	0.00 x 0.50	54	100% Cotton
Ele - Baby Pink/White	ELE00BPHW	\$8.93	12.50 x 10.38	54	100% Cotton
Fancy - Mist/Putty	FANCYMTPY	\$8.93	5.63 x 5.38	54	100% Cotton
Giraffe - Putty/Mist	GIRAFPYMT	\$8.93	25.50 x 31.00	54	100% Cotton
Hooty - True Turquoise	HOOTYTT	\$8.93	12.00 x 11.00	54	100% Cotton
Hooty - Village/Natural	HOOTYVENT	\$8.93	11.75 x 12.50	54	100% Cotton
Jamestown - Black	JAMESBK	\$8.93	12.00 x 20.00	54	100% Cotton
Jungle Babies - Mist/Putty	JUNGLMTPY	\$8.93	25.00 x 27.00	54	100% Cotton
Keys - Linen/Kelp	KEYSLNKP	\$12.18	13.00 x 12.50	54	87% Cotton, 13% Polyurethane
Little Tiger - Black/White	LITTLBKWH	\$8.93	2.50 x 2.62	54	100% Cotton
Madison - Black	MADISBKWH	\$8.93	3.63 x 3.63	54	100% Cotton
Madison - Cozy/Bella	MADISCYBA	\$8.93	3.62 x 3.62	54	100% Cotton
Mod Dots - Village/Natural	MODDOTSVENT	\$8.93	19.00 x 12.00	54	100% Cotton
Morgan - Mist/Putty	MORGAMTPY	\$8.93	0.00 x 3.38	54	100% Cotton
Murphy Eaton Blue Linen	MUR-EBL	\$12.18	0.12 x 0.19	54	87% Cotton, 13% Rayon
Nora - Kelp/Linen	NORAKPLN	\$12.18	13.50 x 12.25	54	87% Cotton, 13% Rayon
Ozborne - Black	OZBOUBK	\$8.93	12.50 x 12.50	54	100% Cotton
Ozborn - Chartreuse	OZBOUCHWH	\$8.93	12.50 x 12.50	54	100% Cotton
Ozborne - Candy Pink	OZBOUCPWH	\$8.93	12.50 x 12.50	54	100% Cotton
Ozborne - Lipstick	OZBOULK	\$8.93	12.50 x 12.50	54	100% Cotton
Paisley - Chocolate/Natural	PAISLCHNA	\$8.93	12.50 x 12.50	54	100% Cotton
Paisley - Candy Pink	PAISLCP	\$8.93	12.50 x 12.50	54	100% Cotton
Peace - Black/White	PEACEBKWH	\$8.93	7.38 x 8.32	54	100% Cotton
Peace - Candy Pink/White	PEACECPWH	\$8.93	7.38 x 8.32	54	100% Cotton
Peace - Lipstick/White	PEACELK	\$8.93	7.38 x 8.32	54	100% Cotton
Polka Dots - Mist/Putty	POLKAMTPY	\$8.93	3.19 x 3.19	54	100% Cotton
Polka Dots - Putty/Mist	POLKAPYMT	\$8.93	3.19 x 3.19	54	100% Cotton
Shiba - Mist/Putty	SHIBAMTPY	\$8.93	5.00 x 2.38	54	100% Cotton
Small Paisley - Candy Pink	SPAISCPWH	\$8.93	8.50 x 17.25	54	100% Cotton
Stretch - Chartreuse/White	STRETCCHWH	\$8.93	12.50 x 3.50	54	100% Cotton
Stretch - Candy Pink	STRETCP	\$8.93	12.50 x 3.50	54	100% Cotton



PREMIER

PRINTS, INC

Name	SID	Retail	Repeat Size (Inches)	Roll Width (Inches)	Materials
Stretch - White Chartreuse	STRETCWHCH	\$8.93	12.50 x 3.50	54	100% Cotton
Stretch - Cozy/Bella	STRETCYBA	\$8.93	12.50 x 3.50	54	100% Cotton
Suzani Village Brown/ Village Blue	SUZ-VBB	\$8.93	51.25 x 24.38	54	100% Cotton
Suzani - Black	SUZANBK	\$8.93	24.38 x 51.50	54	100% Cotton
Suzani - Candy Pink	SUZANCP	\$8.93	24.38 x 51.50	54	100% Cotton
Suzani - Nile/Denton	SUZANNE	\$13.38	24.38 x 51.50	54	81% Cotton, 19% Rayon
Trey - Mist/Putty	TREYOMTPY	\$8.93	1.00 x 0.00	54	100% Cotton
Tunisia Chartreuse	TUNIRCE	\$8.93	12.50 x 13.50	54	100% Cotton
Twirly - Black	TWIRLBK	\$8.93	13.50 x 27.00	54	100% Cotton
Twirly - Chartreuse	TWIRLCH	\$8.93	13.50 x 27.00	54	100% Cotton
Twirly - Candy Pink	TWIRLCYPK	\$8.93	13.50 x 27.00	54	100% Cotton
Vertical - Black/White	VERTIBKWH	\$8.93	6.00 x 6.00	54	100% Cotton
Wilson - Village/Natural	WILSONVENT	\$8.93	26.25 x 0.00	54	100% Cotton
Zebra - Black	ZEBRABK	\$8.93	24.00 x 24.75	54	100% Cotton
Zig Zag - Bella/Cozy	ZIGZABACY	\$8.93	0.00 x 3.75	54	100% Cotton
Zig Zag - Village Blue/ Natural	ZIGZAGVBNL	\$8.93	3.75 x 0.00	54	100% Cotton
Zig Zag - Village Brown/ Natural	ZIGZAGVBRNL	\$8.93	3.75 x 0.00	54	100% Cotton
Zig Zag - Village/Natural	ZIGZAGVENL	\$8.93	3.75 x 0.00	54	100% Cotton
Zig Zag - Village Green/Natural	ZIGZAGVGGNNL	\$8.93	3.75 x 0.00	54	100% Cotton
Zig Zag Village Rust/ Natural	ZZ-VRN	\$8.93	3.75 x 0.00	54	100% Cotton



Name	SID	Repeat Size (Inches)	Roll Width (Inches)	Materials
Sunbrella Erin Green	4600-0000	0.00 x 0.00	46	100% Acrylic - Solution Dyed
Sunbrella Pacific Blue	4601-0000	0.00 x 0.00	46	100% Acrylic - Solution Dyed
Sunbrella Sunflower Yellow	4602-0000	0.00 x 0.00	46	100% Acrylic - Solution Dyed
Sunbrella Jockey Red	4603-0000	0.00 x 0.00	46	100% Acrylic - Solution Dyed
Sunbrella Natural	4604-0000	0.00 x 0.00	46	100% Acrylic - Solution Dyed
Sunbrella Hemlock Tweed	4605-0000	0.00 x 0.00	46	100% Acrylic - Solution Dyed
Sunbrella Dubonnet Tweed	4606-0000	0.00 x 0.00	46	100% Acrylic - Solution Dyed
Sunbrella Charcoal Tweed	4607-0000	0.00 x 0.00	46	100% Acrylic - Solution Dyed
Sunbrella Black	4608-0000	0.00 x 0.00	46	100% Acrylic - Solution Dyed
Sunbrella Orange	4609-0000	0.00 x 0.00	46	100% Acrylic - Solution Dyed
Sunbrella Turquoise	4610-0000	0.00 x 0.00	46	100% Acrylic - Solution Dyed
Sunbrella Tan	4614-0000	0.00 x 0.00	46	100% Acrylic - Solution Dyed
Sunbrella Mocha	4616-0000	0.00 x 0.00	46	100% Acrylic - Solution Dyed
Sunbrella Royal Blue	4617-0000	0.00 x 0.00	46	100% Acrylic - Solution Dyed
Sunbrella Walnut Brown Tweed	4618-0000	0.00 x 0.00	46	100% Acrylic - Solution Dyed
Sunbrella Beige	4620-0000	0.00 x 0.00	46	100% Acrylic - Solution Dyed
Sunbrella True Brown	4621-0000	0.00 x 0.00	46	100% Acrylic - Solution Dyed
Sunbrella Terra Cotta	4622-0000	0.00 x 0.00	46	100% Acrylic - Solution Dyed
Sunbrella Aquamarine	4623-0000	0.00 x 0.00	46	100% Acrylic - Solution Dyed
Sunbrella Sky Blue	4624-0000	0.00 x 0.00	46	100% Acrylic - Solution Dyed
Sunbrella Navy	4626-0000	0.00 x 0.00	46	100% Acrylic - Solution Dyed
Sunbrella Salmon	4627-0000	0.00 x 0.00	46	100% Acrylic - Solution Dyed
Sunbrella Toast	4628-0000	0.00 x 0.00	46	100% Acrylic - Solution Dyed
Sunbrella Cadet Grey	4630-0000	0.00 x 0.00	46	100% Acrylic - Solution Dyed
Sunbrella Burgundy	4631-0000	0.00 x 0.00	46	100% Acrylic - Solution Dyed
Sunbrella Linen	4633-0000	0.00 x 0.00	46	100% Acrylic - Solution Dyed
Sunbrella Buttercup	4635-0000	0.00 x 0.00	46	100% Acrylic - Solution Dyed
Sunbrella Forest Green	4637-0000	0.00 x 0.00	46	100% Acrylic - Solution Dyed
Sunbrella Coral	4638-0000	0.00 x 0.00	46	100% Acrylic - Solution Dyed
Sunbrella Black Cherry	4640-0000	0.00 x 0.00	46	100% Acrylic - Solution Dyed
Sunbrella Sapphire Blue	4641-0000	0.00 x 0.00	46	100% Acrylic - Solution Dyed
Sunbrella Oyster	4642-0000	0.00 x 0.00	46	100% Acrylic - Solution Dyed
Sunbrella Persian Green	4643-0000	0.00 x 0.00	46	100% Acrylic - Solution Dyed
Sunbrella Charcoal Grey	4644-0000	0.00 x 0.00	46	100% Acrylic - Solution Dyed
Sunbrella Sea Grass Green	4645-0000	0.00 x 0.00	46	100% Acrylic - Solution Dyed
Sunbrella Captain Navy	4646-0000	0.00 x 0.00	46	100% Acrylic - Solution Dyed
Sunbrella Persian Tweed	4647-0000	0.00 x 0.00	46	100% Acrylic - Solution Dyed
Sunbrella Taupe	4648-0000	0.00 x 0.00	46	100% Acrylic - Solution Dyed
Sunbrella Silver	4651-0000	0.00 x 0.00	46	100% Acrylic - Solution Dyed
Sunbrella Mediterranean Blue	4652-0000	0.00 x 0.00	46	100% Acrylic - Solution Dyed
Sunbrella Mediterranean Blue Tweed	4653-0000	0.00 x 0.00	46	100% Acrylic - Solution Dyed
Sunbrella Linen Tweed	4654-0000	0.00 x 0.00	46	100% Acrylic - Solution Dyed



Name	SID	Repeat Size (Inches)	Roll Width (Inches)	Materials
Sunbrella Alpine	4655-0000	0.00 x 0.00	46	100% Acrylic - Solution Dyed
Sunbrella Spruce	4656-0000	0.00 x 0.00	46	100% Acrylic - Solution Dyed
Sunbrella Brass	4658-0000	0.00 x 0.00	46	100% Acrylic - Solution Dyed
Sunbrella Concord	4665-0000	0.00 x 0.00	46	100% Acrylic - Solution Dyed
Sunbrella Logo Red	4666-0000	0.00 x 0.00	46	100% Acrylic - Solution Dyed
Sunbrella Mahogany	4667-0000	0.00 x 0.00	46	100% Acrylic - Solution Dyed
Sunbrella Aspen	4668-0000	0.00 x 0.00	46	100% Acrylic - Solution Dyed
Sunbrella Fern	4671-0000	0.00 x 0.00	46	100% Acrylic - Solution Dyed
Sunbrella Heather Beige	4672-0000	0.00 x 0.00	46	100% Acrylic - Solution Dyed
Sunbrella Spa	4673-0000	0.00 x 0.00	46	100% Acrylic - Solution Dyed
Sunbrella Wheat	4674-0000	0.00 x 0.00	46	100% Acrylic - Solution Dyed
Sunbrella Capri	4675-0000	0.00 x 0.00	46	100% Acrylic - Solution Dyed
Sunbrella Cocoa	4676-0000	0.00 x 0.00	46	100% Acrylic - Solution Dyed
Sunbrella Tuscan	4677-0000	0.00 x 0.00	46	100% Acrylic - Solution Dyed
Sunbrella Marine Blue	4678-0000	0.00 x 0.00	46	100% Acrylic - Solution Dyed
Sunbrella Ocean Blue	4679-0000	0.00 x 0.00	46	100% Acrylic - Solution Dyed
Sunbrella Hemlock Tweed Formal	4705-0000	7.67 x 0.00	46	100% Acrylic - Solution Dyed
Sunbrella Hemlock Tweed Fancy	4751-0000	9.20 x 0.00	46	100% Acrylic - Solution Dyed
Sunbrella Pacific Blue Fancy	4755-0000	7.67 x 0.00	46	100% Acrylic - Solution Dyed
Sunbrella Ombre-Dark Brown/Salmon/Beige	4765-0000	11.50 x 0.00	46	100% Acrylic - Solution Dyed
Sunbrella Burgundy Elite	4772-0000	9.20 x 0.00	46	100% Acrylic - Solution Dyed
Sunbrella Bisque Brown	4773-0000	9.20 x 0.00	46	100% Acrylic - Solution Dyed
Sunbrella Chocolate Chip Fancy	4776-0000	7.67 x 0.00	46	100% Acrylic - Solution Dyed
Sunbrella Grey/Beige Chip Fancy	4777-0000	7.67 x 0.00	46	100% Acrylic - Solution Dyed
Sunbrella Forest Green Fancy	4790-0000	7.67 x 0.00	46	100% Acrylic - Solution Dyed
Sunbrella Beige/White	4796-0000	15.30 x 0.00	46	100% Acrylic - Solution Dyed
Sunbrella Burgundy/Black/White	4798-0000	15.30 x 0.00	46	100% Acrylic - Solution Dyed
Sunbrella Grey/Black/White	4799-0000	11.50 x 0.00	46	100% Acrylic - Solution Dyed
Sunbrella Sapphire Fancy	4802-0000	7.67 x 0.00	46	100% Acrylic - Solution Dyed
Sunbrella Pacific Blue/Natural-6 Bar	4805-0000	7.67 x 0.00	46	100% Acrylic - Solution Dyed
Sunbrella Forest Green/Natural-6 Bar	4806-0000	7.67 x 0.00	46	100% Acrylic - Solution Dyed
Sunbrella Coastal-Brick	4850-0000	9.10 x 0.00	46	100% Acrylic - Solution Dyed
Sunbrella Coastal-Spa	4851-0000	9.10 x 0.00	46	100% Acrylic - Solution Dyed
Sunbrella Coastal-Cornsilk	4852-0000	9.10 x 0.00	46	100% Acrylic - Solution Dyed
Sunbrella Coastal-Cocoa	4853-0000	9.10 x 0.00	46	100% Acrylic - Solution Dyed
Sunbrella Coastal-Herbal	4854-0000	9.10 x 0.00	46	100% Acrylic - Solution Dyed



Name	SID	Repeat Size (Inches)	Roll Width (Inches)	Materials
Sunbrella Captain Navy/ Forest Green/Yellow/Red Regimental	4901-0000	7.67 x 0.00	46	100% Acrylic - Solution Dyed
Sunbrella Captain Navy/ Natural Classic	4902-0000	7.67 x 0.00	46	100% Acrylic - Solution Dyed
Sunbrella Burgundy Transitional	4905-0000	11.50 x 0.00	46	100% Acrylic - Solution Dyed
Sunbrella Sapphire Transitional	4906-0000	11.50 x 0.00	46	100% Acrylic - Solution Dyed
Sunbrella Taupe-5 Bar	4907-0000	9.20 x 0.00	46	100% Acrylic - Solution Dyed
Sunbrella Plum Fancy	4909-0000	9.20 x 0.00	46	100% Acrylic - Solution Dyed
Sunbrella Moss Classic	4911-0000	9.50 x 0.00	46	100% Acrylic - Solution Dyed
Sunbrella Forest Green Transitional	4914-0000	7.75 x 0.00	46	100% Acrylic - Solution Dyed
Sunbrella Navy/Taupe Fancy	4916-0000	9.13 x 0.00	46	100% Acrylic - Solution Dyed
Sunbrella Salmon/Canvas Fancy	4918-0000	9.13 x 0.00	46	100% Acrylic - Solution Dyed
Sunbrella Mediterranean/ Aqua Block Stripe	4919-0000	9.13 x 0.00	46	100% Acrylic - Solution Dyed
Sunbrella Mediterranean/ Canvas Block Stripe	4921-0000	9.13 x 0.00	46	100% Acrylic - Solution Dyed
Sunbrella Alpine/Burgundy Pencil Stripe	4922-0000	7.50 x 0.00	46	100% Acrylic - Solution Dyed
Sunbrella Black Forest Fancy	4923-0000	9.00 x 0.00	46	100% Acrylic - Solution Dyed
Sunbrella Alpine/Terra Cotta Classic	4924-0000	7.50 x 0.00	46	100% Acrylic - Solution Dyed
Sunbrella Alpine/Beige-6 Bar	4928-0000	7.67 x 0.00	46	100% Acrylic - Solution Dyed
Sunbrella Forest Green/ Beige/Natural Fancy Stripe	4932-0000	9.20 x 0.00	46	100% Acrylic - Solution Dyed
Sunbrella Sage/Natural/Beige Fancy Stripe	4933-0000	9.20 x 0.00	46	100% Acrylic - Solution Dyed
Sunbrella Sand Graduated Stripe	4936-0000	11.50 x 0.00	46	100% Acrylic - Solution Dyed
Sunbrella Brass/Black Cherry Classic	4939-0000	7.44 x 0.00	46	100% Acrylic - Solution Dyed
Sunbrella Blended Green Tailored Bar Stripe	4944-0000	9.00 x 0.00	46	100% Acrylic - Solution Dyed
Sunbrella Taupe Tailored Bar Stripe	4945-0000	9.00 x 0.00	46	100% Acrylic - Solution Dyed
Sunbrella Black/Taupe Fancy	4946-0000	9.13 x 0.00	46	100% Acrylic - Solution Dyed
Sunbrella Sapphire Vintage Bar Stripe	4948-0000	7.63 x 0.00	46	100% Acrylic - Solution Dyed
Sunbrella Forest Vintage Bar Stripe	4949-0000	11.44 x 0.00	46	100% Acrylic - Solution Dyed
Sunbrella Sapphire Vintage Classic	4950-0000	11.44 x 0.00	46	100% Acrylic - Solution Dyed
Sunbrella Mahogany/Brass Vintage Stripe	4951-0000	11.44 x 0.00	46	100% Acrylic - Solution Dyed
Sunbrella Brass/Beige Pinstripe	4952-0000	11.44 x 0.00	46	100% Acrylic - Solution Dyed



Name	SID	Repeat Size (Inches)	Roll Width (Inches)	Materials
Sunbrella Heather Beige Classic	4954-0000	7.67 x 0.00	46	100% Acrylic - Solution Dyed
Sunbrella Fern Classic	4955-0000	7.67 x 0.00	46	100% Acrylic - Solution Dyed
Sunbrella Heather Beige-6 Bar	4956-0000	7.67 x 0.00	46	100% Acrylic - Solution Dyed
Sunbrella Aspen Colony Stripe	4957-0000	9.20 x 0.00	46	100% Acrylic - Solution Dyed
Sunbrella Taupe Colony Stripe	4958-0000	9.20 x 0.00	46	100% Acrylic - Solution Dyed
Sunbrella Fern/Heather Beige Block Stripe	4959-0000	11.44 x 0.00	46	100% Acrylic - Solution Dyed
Sunbrella Fern Graduated Stripe	4960-0000	11.50 x 0.00	46	100% Acrylic - Solution Dyed
Sunbrella Putty Regimental	4961-0000	3.83 x 0.00	46	100% Acrylic - Solution Dyed
Sunbrella Captain Navy Regimental	4962-0000	3.83 x 0.00	46	100% Acrylic - Solution Dyed
Sunbrella Forest Green Regimental	4963-0000	3.83 x 0.00	46	100% Acrylic - Solution Dyed
Sunbrella Spice Brass Vintage	4967-0000	23.00 x 0.00	46	100% Acrylic - Solution Dyed
Sunbrella Spa Wheat Vintage	4968-0000	23.00 x 0.00	46	100% Acrylic - Solution Dyed
Sunbrella Henna Fern Vintage	4969-0000	23.00 x 0.00	46	100% Acrylic - Solution Dyed
Sunbrella Lankford-Woodland	4971-0000	11.25 x 0.00	46	100% Acrylic - Solution Dyed
Sunbrella Hartwell-Fiesta	4973-0000	15.10 x 0.00	46	100% Acrylic - Solution Dyed
Sunbrella Hartwell-Lagoon	4974-0000	15.10 x 0.00	46	100% Acrylic - Solution Dyed
Sunbrella Gaston-Seaglass	4975-0000	15.10 x 0.00	46	100% Acrylic - Solution Dyed
Sunbrella Roanoke Blue Jewel	4977-0000	11.21 x 0.00	46	100% Acrylic - Solution Dyed
Sunbrella Carlton Plantain	4980-0000	11.21 x 0.00	46	100% Acrylic - Solution Dyed
Sunbrella Roakoke Blue Mist	4983-0000	5.60 x 0.00	46	100% Acrylic - Solution Dyed
Sunbrella Yellow/White-6 Bar	5702-0000	7.67 x 0.00	46	100% Acrylic - Solution Dyed
Sunbrella Red/White-6 Bar	5703-0000	7.67 x 0.00	46	100% Acrylic - Solution Dyed
Sunbrella Black/White-6 Bar	5704-0000	7.67 x 0.00	46	100% Acrylic - Solution Dyed
Sunbrella Beige/White-6 Bar	5760-0000	7.67 x 0.00	46	100% Acrylic - Solution Dyed
Sunbrella Awning 60	6001-0000	0.00 x 0.00	60	100% Acrylic - Solution Dyed
Sunbrella Awning 60	6003-0000	0.00 x 0.00	60	100% Acrylic - Solution Dyed
Sunbrella Awning 60	6004-0000	0.00 x 0.00	60	100% Acrylic - Solution Dyed
Sunbrella Awning 60	6008-0000	0.00 x 0.00	60	100% Acrylic - Solution Dyed
Sunbrella Awning 60	6020-0000	0.00 x 0.00	60	100% Acrylic - Solution Dyed
Sunbrella Awning 60	6021-0000	0.00 x 0.00	60	100% Acrylic - Solution Dyed
Sunbrella Awning 60	6023-0000	0.00 x 0.00	60	100% Acrylic - Solution Dyed
Sunbrella Awning 60	6030-0000	0.00 x 0.00	60	100% Acrylic - Solution Dyed
Sunbrella Awning 60	6033-0000	0.00 x 0.00	60	100% Acrylic - Solution Dyed
Sunbrella Awning 60	6035-0000	0.00 x 0.00	60	100% Acrylic - Solution Dyed
Sunbrella Awning 60" Forest Green	6037-0000	0.00 x 0.00	60	100% Acrylic - Solution Dyed
Sunbrella Awning 60	6042-0000	0.00 x 0.00	60	100% Acrylic - Solution Dyed
Sunbrella Awning 60	6046-0000	0.00 x 0.00	60	100% Acrylic - Solution Dyed
Sunbrella Awning 60	6049-0000	0.00 x 0.00	60	100% Acrylic - Solution Dyed
Sunbrella Awning 60	6068-0000	0.00 x 0.00	60	100% Acrylic - Solution Dyed
Sunbrella Awning 60	6074-0000	0.00 x 0.00	60	100% Acrylic - Solution Dyed



Name	SID	Repeat Size (Inches)	Roll Width (Inches)	Materials
Sunbrella Awning 60	6075-0000	0.00 x 0.00	60	100% Acrylic - Solution Dyed
Sunbrella Awning 60	6077-0000	0.00 x 0.00	60	100% Acrylic - Solution Dyed
Sunbrella Awning 60	6078-0000	0.00 x 0.00	60	100% Acrylic - Solution Dyed
Sunbrella Awning 60	6079-0000	0.00 x 0.00	60	100% Acrylic - Solution Dyed
Sunbrella Awning 60	6085-0000	0.00 x 0.00	60	100% Acrylic - Solution Dyed



Name	SID	Repeat Size (Inches)	Roll Width (Inches)	Materials
Outdura Forest Green Awning	6001	0.00 x 0.00	60	100% Acrylic - Solution Dyed
Outdura Pacific Blue Awning	6002	0.00 x 0.00	60	100% Acrylic - Solution Dyed
Outdura Captains Navy Awning	6003	0.00 x 0.00	60	100% Acrylic - Solution Dyed
Outdura Burgundy Awning	6004	0.00 x 0.00	60	100% Acrylic - Solution Dyed
Outdura Black Awning	6005	0.00 x 0.00	60	100% Acrylic - Solution Dyed
Outdura Antique Beige Awning	6006	0.00 x 0.00	60	100% Acrylic - Solution Dyed
Outdura Cadet Gray Awning	6008	0.00 x 0.00	60	100% Acrylic - Solution Dyed
Outdura Natural White	6009	0.00 x 0.00	60	100% Acrylic - Solution Dyed
Outdura China Red Awning	6010	0.00 x 0.00	60	100% Acrylic - Solution Dyed
Outdura Taupe Awning	6026	0.00 x 0.00	60	100% Acrylic - Solution Dyed
Outdura Champagne Awning	6037	0.00 x 0.00	60	100% Acrylic - Solution Dyed
Outdura Arcadia Skipper Awning	9600	0.00 x 11.81	60	100% Acrylic - Solution Dyed
Outdura Arcadia Smoke Awning	9601	0.00 x 11.81	60	100% Acrylic - Solution Dyed
Outdura Arcadia Coffee Awning	9602	0.00 x 11.81	60	100% Acrylic - Solution Dyed
Outdura Arcadia Classic Awning	9603	0.00 x 11.81	60	100% Acrylic - Solution Dyed
Outdura Arcadia Sage Awning	9604	0.00 x 11.81	60	100% Acrylic - Solution Dyed
Outdura Bigsur Checkerboard Awning	9610	0.00 x 7.38	60	100% Acrylic - Solution Dyed
Outdura Bigsur Forever Green Awning	9611	0.00 x 7.38	60	100% Acrylic - Solution Dyed
Outdura Bigsur True Blue Awning	9612	0.00 x 7.38	60	100% Acrylic - Solution Dyed
Outdura Bigsur Candycane Awning	9613	0.00 x 7.38	60	100% Acrylic - Solution Dyed
Outdura Bigsur Sunny Awning	9614	0.00 x 7.38	60	100% Acrylic - Solution Dyed
Outdura Bigsur Boathouse Awning	9615	0.00 x 7.38	60	100% Acrylic - Solution Dyed
Outdura Bigsur Nuts Awning	9616	0.00 x 7.38	60	100% Acrylic - Solution Dyed
Outdura Carlisle Cedar Awning	9620	0.00 x 14.75	60	100% Acrylic - Solution Dyed
Outdura Carlisle Bark Awning	9621	0.00 x 14.75	60	100% Acrylic - Solution Dyed
Outdura Carlisle Charcoal Awning	9622	0.00 x 14.75	60	100% Acrylic - Solution Dyed
Outdura Edgewood Pumice Awning	9630	0.00 x 4.56	60	100% Acrylic - Solution Dyed
Outdura Edgewood Palm Awning	9631	0.00 x 4.56	60	100% Acrylic - Solution Dyed
Outdura Edgewood Maroon Awning	9632	0.00 x 4.56	60	100% Acrylic - Solution Dyed
Outdura Edgewood Spice Awning	9633	0.00 x 4.56	60	100% Acrylic - Solution Dyed
Outdura Edgewood Aspen Awning	9634	0.00 x 4.56	60	100% Acrylic - Solution Dyed
Outdura Edgewood Skipper Awning	9635	0.00 x 4.56	60	100% Acrylic - Solution Dyed
Outdura Laurelbay Admiral Awning	9640	0.00 x 5.88	60	100% Acrylic - Solution Dyed



Name	SID	Repeat Size (Inches)	Roll Width (Inches)	Materials
Outdura Laurelbay Meadow Awning	9641	0.00 x 5.88	60	100% Acrylic - Solution Dyed
Outdura Laurelbay Onyx Awning	9642	0.00 x 5.88	60	100% Acrylic - Solution Dyed
Outdura Laurelbay Cedar Awning	9643	0.00 x 5.88	60	100% Acrylic - Solution Dyed
Outdura Laurelbay Nickel Awning	9644	0.00 x 5.88	60	100% Acrylic - Solution Dyed
Outdura Oakgrove Granite Awning	9650	0.00 x 11.81	60	100% Acrylic - Solution Dyed
Outdura Oakgrove Alpine Awning	9651	0.00 x 11.81	60	100% Acrylic - Solution Dyed
Outdura Oakgrove Driftwood Awning	9652	0.00 x 11.81	60	100% Acrylic - Solution Dyed
Outdura Southport Coffee Awning	9660	0.00 x 6.56	60	100% Acrylic - Solution Dyed
Outdura Southport Cedar Awning	9661	0.00 x 6.56	60	100% Acrylic - Solution Dyed
Outdura Southport Federal Awning	9662	0.00 x 6.56	60	100% Acrylic - Solution Dyed
Outdura Southport Cork Awning	9663	0.00 x 6.56	60	100% Acrylic - Solution Dyed
Outdura Summerton Coin Awning	9671	0.00 x 5.88	60	100% Acrylic - Solution Dyed
Outdura Summerton Baltic Awning	9672	0.00 x 5.88	60	100% Acrylic - Solution Dyed
Outdura Summerton Aspen Awning	9673	0.00 x 5.88	60	100% Acrylic - Solution Dyed
Outdura Summerton Garden Awning	9674	0.00 x 5.88	60	100% Acrylic - Solution Dyed



Designer **CUSTOM SOURCE**
Committed to exceed your expectations.

3180 Wetumpka Highway
Montgomery, AL 36110

Toll Free: 800-510-8325
Fax: 334-532-0912
info@designercustomsource.com

CUSHION QUOTE FORM

Date	
Invoice #	

CUSTOMER INFORMATION

Name			Credit Card #		
Phone			Credit Card Type	Exp.	
Bill To			Ship To		
Address			Address		
City	State	ZIP	City	State	ZIP
Email					

CUSHION SPECIFICATIONS

Item (Shape Option Name)	Quantity	Template Enclosed <input checked="" type="checkbox"/>
*Cushion Width		
*Cushion Depth	Cushion Diameter	
Product Description		

Styles

Bench	Steamer
Chair & Seat	Ottoman
Window Seat	Deep Seating
Chaise and Double Chaise	Wicker, Rattan, Settee (Over Stuffed)

NUMBER OF BREAKS

1-2 Sections
2-3 Sections
3-4 Sections

*Maximum finished dimensions: 120" W and 80" D. Please call for special requests.

OPTIONS

Edging Styles <small>(Check all that apply)</small>	Boxed	Knife						
	No Cording	Cording	Fringe	Braid				
Fabric Cording	Single Cord Box	Double Cord Box	Single Cord Knife					
	Standard Outdoor: CummPlush	See back for Fabric Specifications.						
Fill	Standard Indoor: Bio Comfort® Foam	**Please refer to the Workroom Catalog for specific style and write it in.						
	Premium Indoor: Bio Comfort® Foam plus batting							
	Direct Fill: Loose poly fiber							
Foam Thickness	Plush: Loose poly fiber between batting sheets. Back cushions only.							
	2"	3"	4"	5"	6"	7"	8"	
Boxed Thickness	2"	3"	4"	5"	6"	7"	8"	
Tufted								
**Tie Option								
Back Corners	Square	Rounded						
Front Corners	Square	Rounded						
Joining Option	Joining Piece	Pinched						
	Section 1	L	W					
Breaks	Section 2	L	W					
	Section 3	L	W					
	Section 4	L	W					
	Back Cushion Double Chaise	Solid Back	Split Back					

FABRIC SPECIFICATIONS

Fabric Selection	Our Fabric	COM	
Fabric Direction	Vertical	Horizontal	
Fabric 1			
Pattern Name			
Description			
Color			
Fabric Width			
Repeat			
Yards Sent			
Trim 1			
Pattern Name			
Description			
Color			
Fabric Width			
Repeat			
Yards Sent			

NOTES



Designer CUSTOM SOURCE
Committed to exceed your expectations.

3180 Wetumpka Highway
Montgomery, AL 36110

Toll Free: 800-510-8325
Fax: 334-532-0912
info@designercustomsource.com

DRAPERY QUOTE FORM

Date	
Invoice #	

CUSTOMER INFORMATION									
Name					Credit Card #				
Phone					Credit Card Type				
Bill To					Exp.				
Address					Ship To				
City	State	ZIP			Address	City	State	ZIP	
Email									

DRAPE SPECIFICATIONS									
Drapery Style				Quantity					
Product Description									
Rod Face									
# of Widths									
Return Size (3/4" Standard)									
Lining Options	Single Lining	Interlining	Blackout Deluxe DCS						
White	Pinnacle	Classic Napped	Standard						
Ivory	Pinnacle	Classic Napped							
Length			**Width						

OPTIONS									
Grommets (Round)	1 7/16"	1 9/16"	2"	2 1/2"	3"				
Grommets (Square)	1 9/16"	Antique Brass, Nickel, and Black							
Grommet Finish Options	Antique Brass, Brass, Antique Copper, Matte Nickel, Nickel, Black, Frosted Black and Bronze								
Tie Backs									
FABRIC SPECIFICATIONS									
Fabric Selection	Our Fabric	COM							
Fabric Direction	Vertical	Horizontal							
Fabric 1									
Pattern Name									
Description									
Color									
Fabric Width									
Repeat									
Yards Sent									

**Maximum finished dimensions: 150" L – 288" W. Please call for special requests.

STYLES	
Pinched Pleat: Euro and French	Tab Top
Goblet Pleat	Tie Top
Grommet	Rod Pocket
Flat Top	



Designer **CUSTOM** SOURCE
Committed to exceed your expectations.

3180 Wetumpka Highway
Montgomery, AL 36110

Toll Free: 800-510-8325
Fax: 334-532-0912
info@designercustomsource.com

THROW PILLOW QUOTE FORM

Date	
Invoice #	

CUSTOMER INFORMATION						
Name			Credit Card #			
Phone			Credit Card Type	Exp.		
Bill To			Ship To			
Address			Address			
City	State	ZIP	City	State	ZIP	
Email						
PILLOW SPECIFICATIONS						
Item	Quantity	Width	Height			
OPTIONS						
Seam	Knife Edge	Corded	Trim	Flange		
Pillow Insert	Feather/Down	90% / 10%	See back for Fabric Specifications.			
	Poly Bun					
	Foam for Bolsters					
Fabric	Our Fabric	COM				
Cording	Our Cording	COM				
Button	Our Fabric	COM Fabric	COM Button			
Trim	Our Trim	COM Trim				
Tassels	COM Tassels					

STYLES (WXH, SIZE OPTIONS)		
Throw Pillow	12"-34"	12"-34"
Throw Pillow with Center Button	12-30"	12-30"
*Rectangle Flange Pillow	12-26"	12-26"
*Square Flange Pillow	12-26"	12-26"
Lumbar Pillow	8-12"	12-30"
Duvet Pillow	18-24"	18-24"
Boxed Round with Center Button	Sizes Available: 16", 18", and 20"	
Round Sunburst with Center Button	Size Available: 16", 18", and 20"	
Bolster	10-36" Length	6-12" Depth
Bolster with Shirred End and Covered Buttons	10-36" Length	6-12" Depth
Bolster with Contrasting Center Panel	10-36" Length	6-12" Depth

*2" standard flange added to pillow sizes up to 18" width. 2 1/2" flange added to pillow sizes from 20-26".

FABRIC SPECIFICATIONS

Fabric Selection	Our Fabric	COM		
Fabric Direction	Vertical	Horizontal		
Fabric 1				
Pattern Name				
Description				
Color				
Fabric Width				
Repeat				
Yards Sent				
Fabric 2				
Pattern Name				
Description				
Color				
Fabric Width				
Repeat				
Yards Sent				
Fabric 3				
Pattern Name				
Description				
Color				
Fabric Width				
Repeat				
Yards Sent				
Trim				
Pattern Name				
Description				
Color				
Fabric Width				
Repeat				
Yards Sent				

NOTES



Designer CUSTOM SOURCE
Committed to exceed your expectations.

3180 Wetumpka Highway
Montgomery, AL 36110

Toll Free: 800-510-8325
Fax: 334-532-0912
info@designercustomsource.com

UMBRELLA QUOTE FORM

Date	
Invoice #	

CUSTOMER INFORMATION	
Name	Credit Card #
Phone	Credit Card Type
Bill To	Exp.
Address	Ship To
City	Address
State	City
ZIP	State
	ZIP

UMBRELLA SPECIFICATIONS	
Item	Quantity
Product Description	

STYLES				
Market	6.5' Square Aluminum	7.5' Wood	9' Aluminum Frame with Fiberglass Ribs	9' Wood
Patio	7.5' Aluminum Frame with Fiberglass Ribs	8.5' Aluminum Crank Patio Umbrella		
Beach	7.5' Wood			
Floral Collection				
Designer Collection	Calla Lily	Sunflower	Rose	
Sea Island Collection				
	Coral Reef	Fresh Fish	Swept Away	

OPTIONS			
Fabric	Our Fabric	COM	
Pole Color	Black	Champagne	White
Pole Height	Standard	Bar Height	
Canopy Fabric	Single	Alternating	
Vent	Single	Double	
Vent Fabric	Match	Match Alternate	Different
Valance	No	Add	
Logo	No	Single Color	Multicolor
Trim	Our Fabric	COM	
Beach Umbrella Options		Opening System	
		Pop-up With Button	
		Pop-up Without Button	

FABRIC SPECIFICATIONS

Fabric Selection	Our Fabric	COM		
Fabric Direction	Vertical	Horizontal		
Fabric 1				
Pattern Name				
Description				
Color				
Fabric Width				
Repeat				
Yards Sent				
Fabric 2				
Pattern Name				
Description				
Color				
Fabric Width				
Repeat				
Yards Sent				
Fabric 3				
Pattern Name				
Description				
Color				
Fabric Width				
Repeat				
Yards Sent				
Trim				
Pattern Name				
Description				
Color				
Fabric Width				
Repeat				
Yards Sent				

ACCESSORIES

Replacement Canopies	7.5' Market	Vent	Vent Fabric	Valance	Logo
	9' Market	Vent	Vent Fabric	Valance	Logo
Spike Stand	Small		Medium	Large	
Square Stand	Decorative Cast Iron				
Flat Steel Base	Weights	20" – 50 lbs.	26.5" – 78 lbs.	26.5" – 128 lbs.	
	Wheels	Add Wheels	No Wheels		

NOTES



FREQUENTLY ASKED QUESTIONS

How Soon Will My Order Be Shipped?

Since all of our products are made to order, your order will typically ship in 3-4 weeks, depending on the volume of orders we are receiving.

Is It Safe To Use My Credit Card For Online Purchases?

Yes, it's extremely safe. At Designer Custom Source, we provide a secured checkout with Secure Socket Layering (SSL up to 256 bits) for processing your payments online. Add items to your cart and click Secure Checkout to make your payment using a Visa, MasterCard, Discover or American Express. You can also pay using your PayPal account, a personal check or PO (purchase order). Payments using a personal check or purchase order are placed on hold until we receive your check or PO and credit information. Payments will be billed as "OCG LLC" — our parent company name.

How Do I Check The Status Of My Order?

Once you are a registered customer of Designer Custom Source, you can log in and check the status of your order. Or please call us at 800.510.8325.

Delivery Times

In addition to the manufacturing/processing times, add 3-5 business days for Standard UPS or FedEx ground shipping (depending on destination). We normally ship via FedEx or UPS Ground. All shipping costs and times are calculated using normal ground delivery. Most orders can be delivered within 5 business days from the shipping date. Normally, our shipments do not require a signature and are left on your doorstep if you are not available at the time of delivery. Larger orders and products may have to be shipped via LTL truck carrier. Expedited shipping is available and appropriate rates apply.

Do You Ship Out of the United States?

Yes, we have published some research into external services that provide US-based addresses. The providers are called Freight Forwarders because they will forward your US purchases from a central warehouse located in the US to your international location. These companies provide you with a US-based delivery address, which you can use as your shipping address for online purchases at Designer Custom Source or any other online store.

Why Do You Charge Tax Online?

All orders originating in the state of Alabama are subject to state and city tax as required by law due to our Company's corporate location in Montgomery, AL. The exact amount of sales tax applied to your online order will appear in the order review screen once you have entered your zip code.

What Credit Cards Do You Accept For Payment?

We accept MasterCard, Visa, Discover, and American Express.

How Do I Change My Shipping Address On A Current Order?

You can change your shipping address by contacting Customer Service. You will be responsible for any fees associated with redirecting your deliveries and/or lost merchandise. If your order has already been processed or shipped, we will not be able to make any changes.

What Is The Order Cancellation Policy?

Designer Custom Source accepts cancellations and order revisions up to one (1) business day from placing the order. There are some exceptions to this, depending on if the order is already in the production process (i.e. fabric cutting, etc.). All cushion and pillow products appearing on this website are made to order using customer specifications. Once a custom order is in production and the fabric has been cut to your specifications, the fabric is no longer suitable for use on any future orders, and the order cannot be canceled.

Customers will have ninety (90) days to submit their template(s) or COM (customer's own material) for orders with such requirements. If a customer does not respond to our contact attempts within these 90 days, Designer Custom Source has the right to cancel the order(s) and charge the customer a \$45 cancellation processing fee per order.

Customers will have ninety (90) days to resume or cancel their order(s) once they have placed their order(s) on HOLD. If a customer does not contact us or respond to our contact attempts within these 90 days, Designer Custom Source has the right to cancel the order(s) and charge the customer a \$45 cancellation processing fee per order.

Designer Custom Source reserves the right to accept or reject reworks at our own discretion.



FABRIC CARE

General Care & Cleaning Tips for Upholstery

After purchasing a piece of upholstered furniture, it is important to know proper cleaning methods to ensure your item maintains its new appearance for years to come. By following a few simple cleaning tips, you can obtain the maximum amount of use out of your couch, chair or ottoman.

CLEANING INSTRUCTIONS

- When cleaning your upholstery, use a cleaner that also deodorizes, is safe for your fabric and does not contain any harsh chemicals. Also, be sure to lightly brush or vacuum your furniture prior to cleaning. This will prevent dirt from entering the fabric while you clean.
- Apply cleanser to stains using a strong brush. When cleaning, do not rub or scrub the fabric too harshly.
- Use a damp sponge or cloth to remove the remaining cleanser after a minute or two.
- After cleansing, be sure your fabric dries thoroughly. To dry your furniture more quickly, leave a window open or run a fan nearby.
- Consider using a cover to protect your furniture if you have animals or small children. This will help you avoid stains.
- Once a week, remove dirt from the fabric by lightly brushing or vacuuming your upholstered piece. This will prevent dirt from entering the fabric and will assist in preserving its appearance.
- Turn or reverse the cushions on your furniture often so they wear evenly. This will also allow you to notice stains sooner. If you do observe a stain, remember to clean upholstered furniture with the weakest solution possible.

While cleaning upholstered fabrics may not always be simple, putting time into caring for your furniture will ultimately be a rewarding task. After all, upholstered fabrics that have been properly cared for can retain their appearance for several years.

Silk Fabric Care & Cleaning

While dry cleaning is recommended, there may be instances where you prefer to hand wash your silk item. In these cases, follow these guidelines to ensure your silk retains its appearance.

HAND WASHING

- Test for color fastness prior to washing. To do so, place a small portion of the silk in lukewarm or cold water. Afterwards, place white cotton fabric over the silk and press a warm iron. While a faint mark is okay, do not wash if there is any other transfer of color from the silk to the white fabric.
- Do not bleach or boil your silk items.
- Use cleansers designed for delicate lingerie to hand-wash light-colored silk in warm water.
- Use tepid water at least three times to rinse thoroughly.
- Remove surplus water by placing your silk item in a dry, clean towel. Do not leave your silk in wrinkled condition.
- Allow your silk item to dry in a space away from direct sunlight or heat. Once the material is evenly damp, press your silk with a cool iron. Be sure you do not apply too much pressure over seams.
- Do not use a steam iron or try to re-dampen your silk.
- Finish off lightly on the right side.
- Because dark colors are obtained by adding coloring matters, color fastness cannot be guaranteed. Therefore, it is important to be cautious with darker hues.

Sunbrella® Care & Cleaning Overview

All cleaning information provided by Sunbrella®.

One of the best ways to keep Sunbrella® fabrics looking good and to delay deep or vigorous cleaning is to properly maintain the fabrics. This can be accomplished by simply brushing off dirt before it becomes embedded in the fabrics, wiping up spills as soon as they occur or spot cleaning soon after stains occur.

GENERAL OR LIGHT CLEANING

- Brush off any loose dirt.
- Prepare a cleaning solution of 2 ounces (¼ cup) mild soap per gallon of lukewarm water (less than 100°F/38°C).
- Use a sponge or a soft bristle brush to clean.
- Allow cleaning solution to soak into fabric.
- Rinse thoroughly to remove all soap residue.
- Allow fabric to air dry.

SPOT CLEANING

- Apply a light mist of mild soap and water using a spray bottle.
- Work the solution into the stain by lightly scrubbing the area with a sponge or very soft bristle brush.
- Rinse thoroughly to remove all soap residue.
- Blot excess moisture with a clean, soft towel or sponge.
- Wet-vacuum or blot excess water.
- Air dry, repeat steps 3 and 4 until all soap residue is removed.

FOR REMOVABLE SUNBRELLA® FABRIC

Hand-washing

- Soak fabric in a solution of ¼ cup mild soap per gallon of lukewarm water.
- Use a sponge or a soft bristle brush as necessary.
- Rinse thoroughly to remove all soap residue.
- Air dry.

Machine-washing

- Do not machine wash fabric.

HEAVY CLEANING FOR STUBBORN STAINS AND MILDEW

Sunbrella® fabric does not promote mildew growth; however, mildew may grow on dirt and other foreign substances that are not removed from the fabric. To clean mildew or other stubborn stains:

- Prepare a solution of 8 ounces (1 cup) of bleach and 2 ounces (¼ cup) of mild soap per gallon of clean water.
- Spray on entire area and allow to soak into the fabric for 15 minutes.
- Remove stain with a sponge, clean towel or very soft bristle brush.
- Rinse thoroughly to remove all soap residue.
- Allow fabric to air dry.
- If stain and/or mildew are severe, bleach quantities may be increased. See our stain chart for removal of specific stains.

RE-TREATING THE FABRIC FOR EASE OF CLEANING

Sunbrella® fabrics have a special finish that enhances water repellency. The finish is designed to last for several years of normal use, but may be refreshed after a thorough cleaning or extended use.

Glen Raven, Sunbrella's parent company, recommends 303 High Tech Fabric Guard™ as the preferred re-treatment product for Sunbrella® fabrics.

APPLYING 303 HIGH TECH FABRIC GUARD™

303 should be applied to Sunbrella® fabrics after each thorough cleaning, which typically removes the original finish and reduces the fabric's water repellency.

- Clean Sunbrella® fabric, using one of the suggested cleaning methods.
- Allow Sunbrella® to completely air dry.
- Apply 303 High Tech Fabric Guard™ in a well-ventilated area following instructions on the container.
- Apply 303 in a thin, even coat and allow fabric to dry completely.
- Apply a second thin, even coating of 303. (Two light coatings are more effective in restoring fabric water resistance than a single heavy coating.)
- A 15-ounce bottle provides coverage of up to 50 square feet of fabric.)

For more information, visit www.303products.com.

PROFESSIONAL CLEANERS

In evaluating the services of a professional firm, you should inquire about the firm's experience in working with Sunbrella® fabrics and knowledge of cleaning and re-treatment requirements.

DO NOT dry clean Sunbrella® fabrics.

HELPFUL HINTS

Protect the area around your Sunbrella® fabric when using a bleach solution — bleach may discolor non-Sunbrella® fabrics. Always rinse Sunbrella® thoroughly to completely remove bleach.

Sunbrella® fabric air-dries very quickly. Machine drying is not necessary.

If fabric has some wrinkling, use an iron, if necessary, but only on the synthetic* setting. As some irons exceed the recommended 100°F/38°C temperature on the synthetic setting, test a small, inconspicuous area before ironing entire piece.

DO NOT use a steamer or iron set to steam setting.

**Synthetic fabric heat settings normally do not exceed 150°F/66°C.*

Sunbrella® Stain Chart

This chart contains our recommended cleaning methods of Sunbrella® fabric for some of the most common and toughest stains. You may also use Carbona™ Stain Devil cleaning products. Available from national retailers, Carbona™ provides 9 formulas made to get out different types of stains. Apply the number indicated for your stain.

STAIN	RECOMMENDED CLEANING SOLUTIONS	CARBONA™ STAIN DEVIL#
Beer	Dawn® dishwashing liquid (2 oz.) / Water (1 gal.) / White vinegar (3 oz.)	8
Berry	Dawn® dishwashing liquid (2 oz.) / Water (1 gal.) / Ammonia (4-8 oz.)	8
Bird Droppings	Dawn® dishwashing liquid (2 oz.) / Water (1 gal.), or try Goo Gone Grease Cutter (a hand cleaner), Greased Lightning, or Clean Rite Purple Power (available at Wal-Mart, K-Mart, etc.)	
Blood (Dried)	Dawn® dishwashing liquid (2 oz.) / Water (1 gal.) / Ammonia (4-8 oz.)	4
Butter	Volatile solvent (acetone) 100%	5
Charcoal, Pencil Marks	Vacuum, then Dawn® dishwashing liquid (2 oz.) / Water (1 gal.)	3
Catsup Or Mustard	Dawn® dishwashing liquid (2 oz.) / Water (1 gal.)	2
Chewing Gum	Volatile solvent (acetone) 100%	1
Chocolate	Dawn® dishwashing liquid (2 oz.) / Water (1 gal.) / Ammonia (4 oz.)	2
Coffee	Dawn® dishwashing liquid / Water, White vinegar, Volatile solvent (acetone)	8
Cola	Dawn® dishwashing liquid (2 oz.) / Water (1 gal.)	8
Crayon	Paint remover (100%), Oil or grease remover (mix as directed)	3
Egg (Raw)	Dawn® dishwashing liquid (2 oz.) / Water (1 gal.)	4
Grape Juice	Dawn® dishwashing liquid (2 oz.) / Water (1 gal.)	8
Gravy	Dawn® dishwashing liquid (2 oz.) / Water (1 gal.)	2
Grease (Car)	Volatile solvent (acetone) 100%	5
Ink (Permanent, India, Ballpoint)	Paint remover (100%), Volatile solvent (acetone, 100%), Soap and water	3
Iron Rust	Carbona™ Stain Devil #9	9
Lipstick	Paint remover, Oil or grease remover (mix as directed)	6
Mascara	Paint remover (100%), Volatile solvent (acetone, 100%), Dawn® dishwashing liquid (2 oz.) / Water (1 gal.)	8

STAIN	RECOMMENDED CLEANING SOLUTIONS	CARBONA STAIN DEVIL #
Mildew	Bleach (1 cup) / Dawn® dishwashing liquid (2 oz.) / Water (1 gal.)	4
Milk	Dawn® dishwashing liquid (2 oz.) / Water (1 gal.)	8
Nail Polish	Volatile solvent (acetone, 100%)	1
Oil	Volatile solvent (acetone, 100%)	5
Orange Drink	Dawn® dishwashing liquid (2 oz.) / Water (1 gal.)	8
Paint (Latex) Wet	Dawn® dishwashing liquid (2 oz.) / Water (1 gal.)	1
Paint (Latex) Dried	Paint remover (100%), Oil or grease remover (mix as directed)	1
Paint (Oil or Lacquer)	Paint remover (100%), Oil or grease remover (mix as directed)	5
Shoe Polish (Liquid)	Volatile solvent (acetone, 100%)	7
Shoe Polish (Wax)	Apply heated iron over towel, Volatile solvent (acetone, 100%)	1
Suntan Lotion	Pine Power® or pine oil detergent / Water (mix as directed)	5
Tea	Dawn® dishwashing liquid (2 oz.) / Water (1 gal.)	8
Tomato Juice	Dawn® dishwashing liquid (2 oz.) / Water (1 gal.)	2
Tree Sap	Turpentine (100%), Dawn® dishwashing liquid (2 oz.) / Water (1 gal.)	7
Urine	Dawn® dishwashing liquid (2 oz.) / Water (1 gal.) / White vinegar (3 oz.)	8
Vomit	Dawn® dishwashing liquid (2 oz.) / Water (1 gal.) / White vinegar (3 oz.)	8
Food Color	Dawn® dishwashing liquid (2 oz.) / Water (1 gal.) / White vinegar (3 oz.)	6
Wax (Candle)	Apply heated iron over towel, Volatile solvent (acetone, 100%)	1
Wine	Dawn® dishwashing liquid (2 oz.) / Water (1 gal.) / Ammonia (4-8 oz.) / White vinegar (3 oz.)	8

By maintaining the appearance of your Robert Allen® fabric and following a few guidelines to ensure it is properly cared for, you can prolong its use and prevent wear.

CARE INSTRUCTIONS

Because window glass magnifies the sun's rays regardless of the season, it is important to protect your fabrics from the sun. One option is to employ trees and shrubbery to help eliminate sunlight. Otherwise, draw your shades during the day or use awnings when possible to block the sun's rays. In addition, colors can also fade through oxidation, or gas fading, so it is important not to keep your Robert Allen® fabrics in storage for a long period without airing it out. If you are using Robert Allen® fabrics for draperies or drapes, line and interline to prevent fading.

It is important to vacuum your Robert Allen® fabrics often to remove dust and other substances. Also, try to dry clean your fabrics at regular intervals so impurities do not collect. Do not try to remove any spots or stains yourself.

Because most fabrics breathe and retain moisture, few fabrics are constant. This often results in fabric stretching or shrinking as much as 3 percent in length. To prevent even greater changes, do not place your fabrics around heating and cooling vents.

While a finish does not eliminate the necessity of properly caring for fabrics, they often help fabrics resist spotting. Generally, light colors are likely to benefit the most. However, if a stain occurs, it should be given immediate attention by a professional dry cleaner.

Outdura® Care & Cleaning Overview

To avoid dirt from collecting, regularly clean your Outdura® fabric. By simply removing excess soil by lightly brushing your fabric or washing the area with tepid water, you can increase the lifespan of your fabrics.

OUTDURA® INDOOR/OUTDOOR FURNITURE GRADE FABRIC

- To uphold the appearance of your fabric, brush often, clean spills as they arise and spot-clean stains.
- If you wish to hand wash your removable covers, soak the fabric in a gallon of lukewarm water and gently scrub using a sponge or brush. If necessary, add a ¼ cup of mild soap. Be sure to rinse the area completely to remove all residues and allow your fabric to air dry.

- Mist upholstered fabrics with water and mild soap to spot clean. If needed, gently scrub with a sponge or brush. Rinse the piece completely to eliminate all residues and then allow the fabric to air dry. If desired, you may also blot or use a wet-vacuum to decrease drying time.
- To clean more thoroughly, gently scrub your fabric with a mixture of lukewarm water and a mild natural soap, such as Ivory brand soap. Afterward, rinse the area completely to remove any residue.
- To remove stubborn stains or mildew, mix 1 cup of bleach, ¼ cup of mild soap, and a gallon of water. Allow the stained area to soak for 20 minutes prior to gently scrubbing with a sponge or clean towel. Be sure to rinse the area thoroughly and allow the fabric to air dry.
- For light cleaning, mix ¼ cup of mild soap and a gallon of tepid water. Allow the mixture to soak the fabric. Be sure to rinse the area completely and allow your fabric to air dry.
- To spot-clean a removable cover, mist the area with a mixture of water and mild soap, then scrub forcefully with a sponge or brush. Rinse the area completely to remove all residues, then allow the fabric to air dry or blot dry with a wet-vacuum.
- Do not dry clean or steam your Outdura® fabrics. When necessary, use an iron with a synthetic fabric heat setting.
- **Do not machine-wash.**

OUTDURA® DIFFICULT STAIN REMOVAL

STAIN	RECOMMENDED CLEANING SOLUTIONS
Bird Droppings, Ketchup, Cola, Egg (Raw), Grape Juice, Latex Paint (Wet), Milk, Mustard, Orange Drink, Tea, Tomato Juice	Liquid Detergent (2 oz.), Water (1 gal.)
Beer, Urine, Vomit, Watercolor	Liquid Detergent (2 oz.), White Vinegar (3 oz.), Water (1 gal.)
Berry, Blood (Dried), Chocolate	Liquid Detergent (2 oz.), Ammonia (4-8 oz.), Water (1 gal.)
Wine	Liquid Detergent (2 oz.), Ammonia (4-8 oz.), White Vinegar (3 oz.), Water (1 gal.)
Butter, Car Grease, Chewing Gum, Nail Polish, Oil, Shoe Polish (Liquid)	Volatile solvent (acetone, 100%)
Crayon, Lipstick, Paint (Dried latex), Paint (Oil or Lacquer)	Paint remover (100%), Oil or grease remover (follow mixing instructions)
Coffee	Detergent, White vinegar, Volatile solvent (acetone), Water
Ink (Permanent, India, Ballpoint)	Paint remover (100%), Volatile solvent (acetone, 100%), Soap, Water
Mascara	Paint remover (100%), Volatile solvent (acetone), Detergent (2 oz.), Water (1 gal.)
Iron Rust	Oxalic or Citrus Acids, Water
Mildew	Bleach (1 cup), Liquid Detergent (2 oz.), Water (1 gal.)
Shoe Polish (Wax), Wax (Candle)	Volatile solvent (acetone, 100%), Apply heated iron over towel
Suntan Lotion	Pine oil detergent, Water (follow mixing instructions)
Tree Sap	Turpentine (100%), Liquid Detergent (2 oz.), Water (1 gal.)
Charcoal, Pencil Marks	Vacuum, then Liquid Detergent (2 oz.), Water (1 gal.)



RETURN & SHIPPING POLICY

Custom orders, special orders, fabric-by-the-yard orders and closeout orders are **non-returnable and cannot be cancelled** once placed due to the custom and made-to-order processes involved. Personalized or logo/company promotional products cannot be returned for any reason.

Any problems or concerns with custom-made products must be reported within 15 business days of receipt. Our workmanship is guaranteed within 6 months of receipt of your custom-made product. Please contact customer service with your concerns. For more information, please read our Terms & Conditions.

If, for whatever reason, you are not completely satisfied with your purchase of a non-custom product (one not made to your specific dimensions and fabric choice), you may return **UNUSED, RESALEABLE** products to us for a refund, exchange, or company credit, provided you notify us to receive a Return Authorization code, and we receive the item back in our warehouse within 12 days of the original date of delivery. A restocking fee of 25% will apply.

International orders shipped via a freight forwarder to points outside the continental United States are **non-returnable**.

Order shortages, damages or discrepancies must be claimed within 2 business days of receipt of order. All returns and refunds are subject to final approval from Designer Custom Source's Customer Service Department. A 25% restocking fee may apply depending on the quantity and style of items being returned.

If an order is refused, shipping charges are non-refundable and all restocking fees will still apply. If a customer refuses a package, they will be charged for any costs we incur in

having the packages returned to us. If a customer refuses a personalized, non-refundable item, they cannot receive any credits by simply refusing the delivery, and they will be charged an additional charge for any return fees we incur after the package is refused. The refused package shall remain in the possession of Designer Custom Source until such time as the customer remits payment for us to send the item(s) again. If payment is not received within 30 days of the first failed delivery, then the item is forfeited.

Shipping charges are non-refundable.

Items with Free Shipping

Returns on items that included 'Free Shipping' will be credited for the item **ONLY** minus the original shipping charges we incurred to ship the item(s) out to you and restocking fees will still apply. 'Free Shipping' will no longer apply once the item is returned. You will be responsible for the return shipping charges, as well as the shipping charges to send your replacement item.

Damage in Shipping

Please check your order immediately upon receipt and notify us if the item has been damaged. Please report the damage within 48 hours to our Customer Service Department during normal customer service hours. We will need photos of the damaged item, as well as photos of the box in which the damaged item was shipped. Please email us images no larger than 300k each. Photographs, sized 4" x 6", can also be mailed to our corporate offices if you are unable to email them. We must have the images in order to notify the shipping company and file the necessary damage claims. After claim is presented to the shipping company, we will arrange to have damaged items and their packaging inspected, returned and replaced.

IMPORTANT: Please keep original shipping containers and packaging in which your item was received, as they are needed for inspection.

Incorrect Shipping Information

Please verify shipping address(es) before placing your order(s). If incorrect shipping information is submitted, you will be responsible for any fees associated with redirecting your deliveries and/or lost merchandise.

Custom Cushion Shipping

Please be advised that your cushion will be folded for shipment if:

- Cushion thickness is less than 4" and the length exceeds 106"
- Cushion thickness is less than 4" and if the length added to the girth [2 x (L + W)] exceeds 129"

Custom Orders & Closeout Items

Customized and custom-made items cannot be returned. These are orders by which the customer chooses the color design, frame, custom cut fabric, logo/personalized products, etc. Designer Custom Source will make a fair attempt to offer alternatives that address your concern. Items marked Closeout are not returnable — they are first quality but are no longer manufactured or stocked at Designer Custom Source. Closeout and sale items are not returnable or exchangeable.

Product Returns

International orders shipped via a freight forwarder to points outside the continental United States are **non-returnable**.

STOCKED INVENTORY (NON-CUSTOM)

If you are unsatisfied with your purchase, our Customer Service Department will assist you within 3 business days with the proper return approval and shipping instructions. Items will be subject to a factory restocking charge of 25% depending on the quantity and style of items being returned. To avoid restocking fees, you can opt to send back your original purchase and exchange for equal or higher value exchange. Restocking fees are charged to handle our administration fees of the return which include but are not limited to the following:

1. The Return Authorization
2. Manual Inventory Update in our System
3. Receiving of the Return, and
4. Restocking in Our Warehouse.

Customers are responsible for returning the item in the original shipping containers and in saleable condition. Credit will be given for the price of the item only. Credit is not issued for shipping charges. If the return item was a part of the Free Shipping and Handling promotion, the eligible refund amount will be the purchase price minus our shipping cost. Claims will not be made on items improperly or insecurely packaged. Credit will be issued when we receive the returned item in good condition at the factory.

Warranty Returns

To return items that meet our warranty guidelines, refer to our return procedures for complete instructions.

RETURN PROCEDURES

In order to process your warranty claim, please follow these procedures so that we may expedite our service to you:

- Notify Designer Custom Source of the concern with your product(s).
- A Designer Custom Source employee will assist you with processing your claim.
- If the concern is covered under warranty, Designer Custom Source will direct you to either return the product or part to our corporate headquarters in Montgomery, Alabama.
- The return will not be accepted without a Return Authorization Number that a Designer Custom Source customer service representative will provide to you.
- You will be provided an address to which you can return your order. An entire replacement, replacement part, or repaired product will be sent to you after the return is verified by a Designer Custom Source customer service representative.
- If a problem occurs after the warranty period, you may request a repair or replacement quote after inspection of the damage. Freight charges both ways will be your responsibility.

